



1 LOCATION PLAN
NOT TO SCALE



SULLIVAN

PERMIT SET

PROJECT CONTACTS:	ENERGY CODE NOTES:	TREE NOTES:	CODES:																																																																																																																			
<p>OWNER: JOHN SULLIVAN 8240 SE 28TH ST. MERCER ISLAND, WA, 98040 jvsul2013@gmail.com 847.420.1434</p> <p>ARCHITECT: SHED ARCHITECTURE & DESIGN 1401 S JACKSON ST SEATTLE WA 98144 USA CONTACT: CLAYTON HERBST CLAYTON@SHEDBUILT.COM 708.567.9476</p> <p>STRUCTURAL ENGINEER: HARRIOTT VALENTINE ENGINEERS INC. CONTACT: JAMES HARRIOTT jharriot@harrriottvalentine.com 206.624.4760</p> <p>GEOTECHNICAL ENGINEER: COBALL GEOSCIENCES CONTACT: PHIL HABERMAN phil@cobballgeo.com 206.337.1097</p> <p>CIVIL ENGINEER: INTERLAKEN ENGINEERING CONTACT: MATTHEW HARINGA matt@interlakenengineering.com 206.470.9572</p> <p>MECHANICAL ENGINEER: BEYOND EFFICIENCY CONTACT: NATHAN RUSSELL nate@beyondefficiency.us 307.200.7236</p> <p>ARBORIST: OLYMPIC NURSERY, INC. CONTACT: TOM QUIGLEY tquigley@nrsn.com 206.850.2643</p> <p>CONTRACTOR: TBD CONTACT: TBD</p>	<p>2018 WASHINGTON STATE ENERGY CODE - RESIDENTIAL PRESCRIPTIVE ENERGY CODE COMPLIANCE</p> <p>WSEC TABLE R402.1 INSULATION AND FENESTRATION REQUIREMENTS BY COMPONENT FOR CLIMATE ZONE 5 AND MARINE 4:</p> <table border="1"> <thead> <tr> <th>COMPONENT</th> <th>REQD</th> <th>PROPOSED</th> </tr> </thead> <tbody> <tr> <td>FENESTRATION U:</td> <td>0.30</td> <td>0.28</td> </tr> <tr> <td>SKYLIGHT U:</td> <td>0.50</td> <td>0.42</td> </tr> <tr> <td>CEILING R:</td> <td>49/38</td> <td>52</td> </tr> <tr> <td>WD FRAME WALL R:</td> <td>21 INT</td> <td>25 OR 36</td> </tr> <tr> <td>MASS WALL R:</td> <td>21/21</td> <td>26</td> </tr> <tr> <td>FLOOR R:</td> <td>30</td> <td>N/A</td> </tr> <tr> <td>BLW-GRADE WALL R:</td> <td>10'15/21 NT + TB</td> <td>21 + TB</td> </tr> <tr> <td>SLAB R & DEPTH:</td> <td>10, 2 R</td> <td>10, ALL</td> </tr> <tr> <td>CONDITIONED FLOOR AREA:</td> <td>2,861 SF</td> <td></td> </tr> <tr> <td>FENESTRATION AREA:</td> <td>630 SF</td> <td></td> </tr> </tbody> </table> <p>WSEC TABLE R406.2 FUEL NORMALIZATION CREDITS OPTION 2 - HEAT PUMP FOR AN INITIAL HEATING SYSTEM USING A HEAT PUMP THAT MEETS FEDERAL STANDARDS FOR THE EQUIPMENT LISTED IN TABLE C403.3.2(1)C OR C403.3.2(2) (1.0 PT)</p> <p>WSEC TABLE R406.2 ENERGY CREDITS 1.3 EFFICIENT BUILDING ENVELOPE PRESCRIPTIVE COMPLIANCE IS BASED ON TABLE R402.1.1 WITH THE FOLLOWING MODIFICATIONS: VERTICAL FENESTRATION U = 0.28, FLOOR R-38, SLAB ON GRADE R-10 BELOW SLAB & PERIMETER. (0.5 PT)</p> <p>2.2 AIR LEAKAGE CONTROL AND EFFICIENT VENTILATION COMPLIANCE BASED ON SECTION R402.4.1.2. REDUCE THE TESTED AIR LEAKAGE TO 2.0 AIR CHANGES PER HOUR MAXIMUM AT 50 PASCALS. (1.0 PT)</p> <p>3.5 HIGH EFFICIENCY HVAC EQUIPMENT AIR-SOURCE CENTRALLY DUCTED HEAT PUMP WITH MINIMUM HSPF OF 11. TO QUALIFY TO CLAIM THIS CREDIT, THE BUILDING PERMIT DRAWINGS SHALL SPECIFY THE OPTION BEING SELECTED AND SHALL SPECIFY THE HEATING EQUIPMENT TYPE AND THE MINIMUM EQUIPMENT EFFICIENCY. (1.5 PT)</p> <p>4.1 HIGH-EFFICIENCY HVAC DISTRIBUTION SYSTEM MECH EQPM LOCATED OUTSIDE OF CONDITIONED SPACE. A MAX 10 LINEAL FEET OF RETURN DUCT AND 5 LINEAL FEET OF SUPPLY DUCT CONNECTIONS TO THE EQPM MAY BE OUTSIDE THE DEEPLY BURIED INSULATION. ALL METALLIC DUCTS LOCATED OUTSIDE THE CONDITIONED SPACE MUST HAVE BOTH TRANSVERSE AND LONGITUDINAL JOINTS WITH MASTIC. IF FLEX DUCTS ARE USED THEY CANNOT CONTAIN SPLICES. DUCT LEAKAGE SHALL BE LIMITED TO 0.3 CFM PER 100 SQFT OG CONDITIONED FLOOR AREA. AIR HANDLERS SHALL BE LOCATED WITH THE CONDITIONED SPACE (0.5 PT)</p> <p>5.5 EFFICIENT WATER HEATING WATER HEATING SYSTEM SHALL INCLUDE ELECTRIC HEAT PUMP WATER HEATER MEETING THE STANDARDS FOR TIER III OF NEEA'S ADVANCED WATER HEATING SPECIFICATION. (2.0 PT)</p> <p>SUMMARY: REQD POINTS: 6 PROPOSED POINTS: 6.5</p> <p>AIR SEALING TESTING: THE DWELLING UNIT SHALL BE TESTED AND VERIFIED AS HAVING AN AIR LEAKAGE RATE OF NOT EXCEEDING 2.0 AIR CHANGES PER HOUR. TESTING SHALL BE CONDUCTED WITH A BLOWER DOOR PER IRC N1102.4.1.2 (R402.4.1.2)</p>	COMPONENT	REQD	PROPOSED	FENESTRATION U:	0.30	0.28	SKYLIGHT U:	0.50	0.42	CEILING R:	49/38	52	WD FRAME WALL R:	21 INT	25 OR 36	MASS WALL R:	21/21	26	FLOOR R:	30	N/A	BLW-GRADE WALL R:	10'15/21 NT + TB	21 + TB	SLAB R & DEPTH:	10, 2 R	10, ALL	CONDITIONED FLOOR AREA:	2,861 SF		FENESTRATION AREA:	630 SF		<p>1 EXISTING NON-EXCEPTIONAL TREE TO BE REMOVED PER REQD LISTED IN MICC 19.02.020. REFER TO REPORT PRODUCED BY QUALIFIED ARBORIST THOMAS QUIGLEY AT OLYMPIC NURSERY DATED 12.06.2022</p> <p>CRITICAL AREAS:</p> <p>CRITICAL AREA REVIEW: ->CRITICAL AREAS ON SITE: -LANDSLIDE, EROSION, SEISMIC ->REFER TO GEOTECHNICAL REPORT PRODUCED BY COBALL GEOSCIENCES ->CRITICAL AREA REVIEW TYPE 2 WAS SUBMITTED ON 2022.12.08 UNDER PERMIT NUMBER CA022-023 AND IS STILL IN REVIEW AS OF TIME OF BUILDING PERMIT SUBMITTAL</p> <p>GENERAL PROVISIONS: ->PER MICC 19.07.160.F.2: LAND CLEARING, GRADING, FILLING AND FOUNDATION WORK ARE NOT PERMITTED BETWEEN OCTOBER 1 AND APRIL 1 (UNLESS A WAIVER IS APPLIED FOR AND APPROVED) ->EXCAVATION SHOWN ON STRUCTURAL TEMPORARY SHORING PLAN</p> <p>FIRE:</p> <p>SPRINKLERS: PER AMENDMENT TO IRC 17.02.020.B, IRC AV107.2 AN APPROVED AUTOMATIC FIRE SPRINKLER SYSTEM SHALL BE INSTALLED THROUGHOUT THE RESIDENCE IN NEW SINGLE-FAMILY HOMES IN ACCORDANCE WITH NFPA STANDARDS NFPA 13R FIRE SPRINKLER TO BE INSTALLED PER CoMI AND STAND NFPA 13R STANDARDS. A SEPRATE FIRE PERMIT IS REQUIRED.</p> <p>FIRE ALARM: ->NFPA 72 MONITORED CHAPTER 29 FIRE ALARM SYSTEM TO BE INSTALLED PER CoMI AND NFPA 72 CHP. 29 STANDARDS. A SEPERATE FIRE PERMIT IS REQUIRED.</p> <p>FIREBLOCKING: ->INSTALL FIRESTOPPING PER IRC 2018 R302.11</p> <p>DRAINAGE NOTES:</p> <p>STORMWATER MANAGEMENT: ON-SITE DETENTION SYSTEM: IMPERVIOUS SURFACE RUNOFF AND FOOTING DRAINS TO BE TIGHTLINED TO A DETENTION TANK UNDER THE DRIVEWAY BEFORE DISCHARGING TO EXISTING MERCER ISLAND STORM DRAIN. REFER TO CIVIL DRAWINGS FOR MORE INFORMATION.</p> <p>ELEVATOR NOTES:</p> <p>ELEV INFO: MANUFACTURER: SYMMETRY ELEVATOR MODEL: HYDRAULIC DRIVE 40X54 DRIVE SYSTEM: HYDRAULIC DRIVE SYSTEM</p> <p>CODE INFO: ELEVATOR AND ALL ASSOCIATED COMPONENTS SHALL BE MANUFACTURED AND INSTALLED TO MEET ASME A17.1 REQUIREMENTS</p> <p>GENERAL NOTES:</p> <ol style="list-style-type: none"> THE DRAWINGS ARE INTENDED TO ONLY PARTIALLY DESCRIBE THE SCOPE OF WORK FOR THE PROJECT. ANY WORK NOT SHOWN HERE, BUT REQUIRED BY CODE, OR THE SPECIFICATIONS, OR TO MAKE THE WORK COMPLETE, SHALL BE PROVIDED AS PART OF THE WORK. IT IS THE INTENT OF THE DOCUMENTS THAT ALL WORK COMPLIES WITH ALL APPLICABLE LOCAL, STATE & NATIONAL CODES / ORDINANCES IN EFFECT AT THE DATE OF PERMIT SUBMITTAL. NOTHING IN THESE DRAWINGS SHALL BE CONSTRUED TO GRANT APPROVAL FOR ANY CODE VIOLATION. ANY ERRORS, INCONSISTENCIES OR OMISSIONS SHALL BE REPORTED PROMPTLY TO THE ARCHITECT. DO NOT SCALE THE DRAWINGS. THE CONTRACTOR SHALL USE DIMENSIONS SHOWN ON THE DRAWINGS AND ACTUAL FIELD MEASUREMENTS. IF DISCREPANCIES ARE FOUND, THE ARCHITECT SHALL BE NOTIFIED AT ONCE. CONTRACTOR SHALL VERIFY THE DIMENSIONS REQUIRED FOR ALL EQUIPMENT, APPLIANCES, FIXTURES, CABINETS, DUCTWORK, AND OPENINGS BEFORE FRAMING BEGINS. THE CONTRACTOR SHALL COORDINATE WITH THE SUBCONTRACTORS OF ALL TRADES TO VERIFY THE SIZES AND LOCATIONS OF OPENINGS THROUGH FLOORS, WALLS, CEILINGS, AND ROOFS FOR DUCTS, PIPES, CONDUITS, AND EQUIPMENT. THE CONTRACTOR SHALL COORDINATE THE LOCATION AND INSTALLATION OF WOOD BACKING, BLOCKING, FURRING, AND STRIPPING AS REQUIRED FOR THE INSTALLATION AND ATTACHMENT OF WORK OF ALL TRADES. PROVIDE FIRE RESISTANCE CLOSURE MEETING THE REQUIREMENTS OF THE GOVERNING FIRE AUTHORITIES AT ALL GAPS AROUND PENETRATING DUCTS, PIPES, CONDUITS, ETC. AT ALL FIRE RATED BUILDING WALLS, PARTITIONS, CEILINGS, FLOORS AND ROOFS. COORDINATE WITH MECHANICAL AND ELECTRICAL CONTRACTORS FOR EXACT LOCATIONS, TYPES AND SIZE OF ACCESS DOORS REQUIRED BY THEIR WORK. PROVIDE ACCESS FOR ALL CONCEALED VALVES, DAMPER CONTROLS, FIRE DAMPER LINKAGE, ELECTRICAL JUNCTION BOXES, ETC. DRAWINGS MAY NOT SHOW ALL REQUIRED ACCESS PANELS. INDICATE REQUIRED ACCESS DOORS ON THE COORDINATION DRAWINGS. OBTAIN ARCHITECT'S APPROVAL FOR LOCATIONS OF ACCESS DOORS PRIOR TO INSTALLATION. THE CONTRACTOR SHALL SECURE AND PAY FOR ALL PERMITS AND GOVERNMENTAL FEES, LICENSES AND INSPECTIONS NECESSARY FOR THE PROPER EXECUTION AND COMPLETION OF THE WORK, WITH THE EXCEPTION OF THE MATER USE PERMIT AND THE BUILDING PERMIT. PRIOR TO THE COMMENCEMENT OF ANY CONSTRUCTION OR SITE DEVELOPMENT ACTIVITY, THE CONTRACTOR SHALL SCHEDULE PRE-CONSTRUCTION MEETINGS WITH THE APPROPRIATE REGULATORY ENTITIES. PRIOR TO THE COMMENCEMENT OF ANY CONSTRUCTION OR SITE DEVELOPMENT ACTIVITY, THE CONTRACTOR AND/OR ARCHITECT SHALL SCHEDULE A PRE-CONSTRUCTION MEETING WITH THE PROJECT TEAM MEMBERS FOR THE PURPOSE OF ANSWERING INITIAL QUESTIONS, CLARIFYING AREAS OF CONCERN, AND FORMALIZING A CONSTRUCTION ADMINISTRATION PROCESS. THE MEETING SHALL INCLUDE THE ARCHITECT, GENERAL CONTRACTOR, OWNER, STRUCTURAL ENGINEER AND CIVIL ENGINEER. 	<p>THIS PROJECT SHALL COMPLY WITH THE FOLLOWING CODES:</p> <p>MERCER ISLAND CITY CODE 2018 INTERNATIONAL BUILDING CODE 2018 INTERNATIONAL MECHANICAL CODE NATIONAL FUEL GAS CODE (ANSI Z223.1/NFPA 58) LIQUEFIED PATROLEUM (NFPA 58) INTERNATIONAL FUEL GAS CODE 2018 INTERNATIONAL FIRE CODE 2018 UNIFORM PLUMBING CODE WASHINGTON STATE ENERGY CODE</p> <p>SHEET INDEX:</p> <table border="1"> <tbody> <tr> <td>G-000</td> <td>COVER SHEET</td> </tr> <tr> <td>SV-1</td> <td>SURVEY</td> </tr> <tr> <td>C1</td> <td>TESC / DEMO / CSWPPP</td> </tr> <tr> <td>C2</td> <td>DRAINAGE SITE PLAN</td> </tr> <tr> <td>C3</td> <td>DETENTION DETAIL</td> </tr> <tr> <td>A-001</td> <td>SITE PLAN & DIAGRAMS</td> </tr> <tr> <td>A-002</td> <td>GFA+BASEMENT CALC</td> </tr> <tr> <td>A-003</td> <td>LANDSCAPE PLAN</td> </tr> <tr> <td>A-100</td> <td>FOUNDATION FLOOR PLAN</td> </tr> <tr> <td>A-110</td> <td>GARAGE FLOOR PLAN</td> </tr> <tr> <td>A-111</td> <td>LEVEL 1 FLOOR PLAN</td> </tr> <tr> <td>A-112</td> <td>LEVEL 2 FLOOR PLAN</td> </tr> <tr> <td>A-113</td> <td>ROOF PLAN</td> </tr> <tr> <td>A-201</td> <td>EXTERIOR ELEVATIONS</td> </tr> <tr> <td>A-202</td> <td>EXTERIOR ELEVATIONS</td> </tr> <tr> <td>A-203</td> <td>EXTERIOR ELEVATIONS</td> </tr> <tr> <td>A-301</td> <td>BLDG SECTIONS</td> </tr> <tr> <td>A-302</td> <td>BLDG SECTIONS</td> </tr> <tr> <td>A-303</td> <td>BLDG SECTIONS</td> </tr> <tr> <td>A-501</td> <td>EXTERIOR DETAILS</td> </tr> <tr> <td>A-502</td> <td>EXTERIOR DETAILS</td> </tr> <tr> <td>A-601</td> <td>TYPICAL ASSEMBLIES</td> </tr> <tr> <td>A-602</td> <td>SCHEDULES</td> </tr> <tr> <td>S1.0</td> <td>GENERAL STRUCTURAL NOTES</td> </tr> <tr> <td>S1.1</td> <td>GENERAL STRUCTURAL NOTES</td> </tr> <tr> <td>S2.0</td> <td>FOUNDATION PLAN</td> </tr> <tr> <td>S2.1</td> <td>MAIN FLOOR FRAMING PLAN</td> </tr> <tr> <td>S2.2</td> <td>LOFT FRAMING PLAN</td> </tr> <tr> <td>S2.3</td> <td>ROOF FRAMING PLAN</td> </tr> <tr> <td>S2.4</td> <td>ROOF FRAMING PLAN</td> </tr> <tr> <td>S3.0</td> <td>STRUCTURAL DETAILS</td> </tr> <tr> <td>S3.1</td> <td>STRUCTURAL DETAILS</td> </tr> <tr> <td>S3.2</td> <td>STRUCTURAL DETAILS</td> </tr> <tr> <td>S4.0</td> <td>STRUCTURAL DETAILS</td> </tr> <tr> <td>T1.0</td> <td>TEMPORARY SHORING GENERAL NOTES</td> </tr> <tr> <td>T2.0</td> <td>TEMPORARY SHORING PLAN</td> </tr> <tr> <td>T3.0</td> <td>TEMPORARY SHORING ELEVATIONS</td> </tr> <tr> <td>T3.1</td> <td>TEMPORARY SHORING ELEVATIONS</td> </tr> <tr> <td>T3.2</td> <td>TEMPORARY SHORING ELEVATIONS</td> </tr> <tr> <td>T3.3</td> <td>TEMPORARY SHORING DETAILS</td> </tr> <tr> <td>T3.4</td> <td>TEMPORARY SHORING DETAILS</td> </tr> </tbody> </table>	G-000	COVER SHEET	SV-1	SURVEY	C1	TESC / DEMO / CSWPPP	C2	DRAINAGE SITE PLAN	C3	DETENTION DETAIL	A-001	SITE PLAN & DIAGRAMS	A-002	GFA+BASEMENT CALC	A-003	LANDSCAPE PLAN	A-100	FOUNDATION FLOOR PLAN	A-110	GARAGE FLOOR PLAN	A-111	LEVEL 1 FLOOR PLAN	A-112	LEVEL 2 FLOOR PLAN	A-113	ROOF PLAN	A-201	EXTERIOR ELEVATIONS	A-202	EXTERIOR ELEVATIONS	A-203	EXTERIOR ELEVATIONS	A-301	BLDG SECTIONS	A-302	BLDG SECTIONS	A-303	BLDG SECTIONS	A-501	EXTERIOR DETAILS	A-502	EXTERIOR DETAILS	A-601	TYPICAL ASSEMBLIES	A-602	SCHEDULES	S1.0	GENERAL STRUCTURAL NOTES	S1.1	GENERAL STRUCTURAL NOTES	S2.0	FOUNDATION PLAN	S2.1	MAIN FLOOR FRAMING PLAN	S2.2	LOFT FRAMING PLAN	S2.3	ROOF FRAMING PLAN	S2.4	ROOF FRAMING PLAN	S3.0	STRUCTURAL DETAILS	S3.1	STRUCTURAL DETAILS	S3.2	STRUCTURAL DETAILS	S4.0	STRUCTURAL DETAILS	T1.0	TEMPORARY SHORING GENERAL NOTES	T2.0	TEMPORARY SHORING PLAN	T3.0	TEMPORARY SHORING ELEVATIONS	T3.1	TEMPORARY SHORING ELEVATIONS	T3.2	TEMPORARY SHORING ELEVATIONS	T3.3	TEMPORARY SHORING DETAILS	T3.4	TEMPORARY SHORING DETAILS
COMPONENT	REQD	PROPOSED																																																																																																																				
FENESTRATION U:	0.30	0.28																																																																																																																				
SKYLIGHT U:	0.50	0.42																																																																																																																				
CEILING R:	49/38	52																																																																																																																				
WD FRAME WALL R:	21 INT	25 OR 36																																																																																																																				
MASS WALL R:	21/21	26																																																																																																																				
FLOOR R:	30	N/A																																																																																																																				
BLW-GRADE WALL R:	10'15/21 NT + TB	21 + TB																																																																																																																				
SLAB R & DEPTH:	10, 2 R	10, ALL																																																																																																																				
CONDITIONED FLOOR AREA:	2,861 SF																																																																																																																					
FENESTRATION AREA:	630 SF																																																																																																																					
G-000	COVER SHEET																																																																																																																					
SV-1	SURVEY																																																																																																																					
C1	TESC / DEMO / CSWPPP																																																																																																																					
C2	DRAINAGE SITE PLAN																																																																																																																					
C3	DETENTION DETAIL																																																																																																																					
A-001	SITE PLAN & DIAGRAMS																																																																																																																					
A-002	GFA+BASEMENT CALC																																																																																																																					
A-003	LANDSCAPE PLAN																																																																																																																					
A-100	FOUNDATION FLOOR PLAN																																																																																																																					
A-110	GARAGE FLOOR PLAN																																																																																																																					
A-111	LEVEL 1 FLOOR PLAN																																																																																																																					
A-112	LEVEL 2 FLOOR PLAN																																																																																																																					
A-113	ROOF PLAN																																																																																																																					
A-201	EXTERIOR ELEVATIONS																																																																																																																					
A-202	EXTERIOR ELEVATIONS																																																																																																																					
A-203	EXTERIOR ELEVATIONS																																																																																																																					
A-301	BLDG SECTIONS																																																																																																																					
A-302	BLDG SECTIONS																																																																																																																					
A-303	BLDG SECTIONS																																																																																																																					
A-501	EXTERIOR DETAILS																																																																																																																					
A-502	EXTERIOR DETAILS																																																																																																																					
A-601	TYPICAL ASSEMBLIES																																																																																																																					
A-602	SCHEDULES																																																																																																																					
S1.0	GENERAL STRUCTURAL NOTES																																																																																																																					
S1.1	GENERAL STRUCTURAL NOTES																																																																																																																					
S2.0	FOUNDATION PLAN																																																																																																																					
S2.1	MAIN FLOOR FRAMING PLAN																																																																																																																					
S2.2	LOFT FRAMING PLAN																																																																																																																					
S2.3	ROOF FRAMING PLAN																																																																																																																					
S2.4	ROOF FRAMING PLAN																																																																																																																					
S3.0	STRUCTURAL DETAILS																																																																																																																					
S3.1	STRUCTURAL DETAILS																																																																																																																					
S3.2	STRUCTURAL DETAILS																																																																																																																					
S4.0	STRUCTURAL DETAILS																																																																																																																					
T1.0	TEMPORARY SHORING GENERAL NOTES																																																																																																																					
T2.0	TEMPORARY SHORING PLAN																																																																																																																					
T3.0	TEMPORARY SHORING ELEVATIONS																																																																																																																					
T3.1	TEMPORARY SHORING ELEVATIONS																																																																																																																					
T3.2	TEMPORARY SHORING ELEVATIONS																																																																																																																					
T3.3	TEMPORARY SHORING DETAILS																																																																																																																					
T3.4	TEMPORARY SHORING DETAILS																																																																																																																					
<p>PROJECT INFO:</p> <p>PROJECT DESCRIPTION: NEW CONSTRUCTION, SINGLE-FAMILY RESIDENCE</p> <p>PROJECT ADDRESS: 3024 69TH AVE SE MERCER ISLAND, WA, 98040</p> <p>LEGAL DESCRIPTION: EAST SEATTLE BLKS 39-40 PLAT BLOCK: 40 PLAT LOT: 17-18-19 QUARTER, SECTION, TOWNSHIP, RANGE: NW-12-24-4</p> <p>PARCEL NUMBER: 217510-0315</p> <p>EASEMENTS: No. 4635710 SEWER EASEMENT (5' SOUTH SIDE YARD) COVENANTS W/ NEIGHBORING PROP. @ 3015 70TH AVE SE ->VIEW EASEMENT (HEIGHT RESTRICTION 27' ABV SEA LEVEL) ->UTILITY EASEMENT (10' NORTH SIDE YARD) ->YARD EASEMENT (18' REAR YARD)</p>	<p>BUILDING NOTES:</p> <p>CONSTRUCTION TYPE: VB, SPRINKLERED</p> <p>DWELLINGS: 1 HOUSE</p> <p>#BEDROOMS: 4</p> <p>#BATHROOMS: 3</p> <p>LAND USE NOTES:</p> <p>ZONING: R-8.4</p> <p>LOT AREA: 8,652 SQFT</p> <p>LOT COVERAGE: 34.2%, REFER TO DIAGRAM ON 3/A-001</p> <p>LOT SLOPE: 28.8%, REFER TO DIAGRAM ON 3/A-001</p> <p>GROSS FLOOR AREA: 2,958.3 SQFT, REFER TO DIAGRAM ON 5/A-002</p> <p>PROPOSED BUILDING HEIGHT: ->19'3" ABV AVERAGE GRADE (PER MICC 19.02.020.E.30 MAX ALLOWED) ->VIEW EASEMENT WITH NEIGHBOR LIMITS HEIGHT TO 27' ABV SEA LEVEL (MAX PER MICC IS 28'3") ->REFER TO 4/A-001 FOR AVERAGE GRADE CALC ->PER MICC 19.02.020.E.2: MAX BUILDING FACADE HEIGHT ON A DOWNHILL SIDE OF A SLOPING LOT SHALL NOT EXCEED 3'0" IN HEIGHT, PROPOSED = 29'-2 1/2" REFER TO 1/A-301</p> <p>SETBACKS: ->PER MICC 19.02.020.C ->FRONT YARD: 20' ->REAR YARD: 25' ->VARIABLE SIDE YARD WIDTH PER 19.02.020.C.1.c: ->LOT LARGER THAN 6,000SQFT ->HOUSE IS TALLER THAN 19' BUT LESS THAN 25', SO SIDE YARD: 7.5'</p> <p>PARKING: ->PER MICC 19.02.020.G.2.b: 2 PARKING SPACES ARE REQUIRED IF GFA<3,000SQFT ->GFA = 2,975.4 SQFT PER CALC ON A-002, LESS THAN 3,000 SQFT, SO 2 PARKING SPACES REQUIRED ->2 COVERED SPACES ARE PROVIDED IN GARAGE TOTAL: 2 PROVIDED</p>	<p>MECH. & ELEC. NOTES:</p> <p>HEATING SYSTEM: AIR-TO-REFRIGERANT ELECTRIC HEAT PUMP, SINGLE OUTDOOR HEAT PUMP UNIT (MHP-1) AND TWO INDOOR AIR HANDLING UNITS (MFC-1, MFC-2) LOCATED IN SOUTH CRAWLSPACE. DUCTED UNITS WILL HAVE 4" DEEP FILTERS ON RETURN AIR DUCTS TO ACCOMMODATE MERV 13 FILTERS</p> <p>MECHANICAL VENTILATION: OUTDOOR AIR VENTILATION WITH HEAT RECOVERY VENTILATOR (HRV); HRV UNIT WILL CONTINUOUSLY EXHAUST FROM EACH BATHROOM AND SUPPLY OUTSIDE AIR TO THE LIVING, BEDROOMS, CRAWLSPACE, AND ATTIC VENTILATION RATE PER IRC 2018 M1505.4.3 Q_{HRV} = 0.3A_{LDUR} + 7.5 (N_{BR-1}) Q_{HRV} = 0.3(2,861) + 7.5(4 + 1) Q_{HRV} = 123.1 CFM (MIN)</p> <p>PER IRC 408.3(2.1) CRAWL SPACE VENTILATION WILL BE PROVIDED WITH A SUPPLY CONNECTION FROM HRV-1 AND A TRANSFER GRILLE WITH AN INSECT SCREEN TRANSFERRING AIR TO LIVING SPACE OPPOSITE CRAWL SPACE. 1 CFM PER 50 SQFT CRAWLSPACE. NORTH CRAWLSPACE INCLUDING BLW STAIRS RATE: 93350-19 CFM. SOUTH CRAWLSPACE RATE: 37150-8 CFM.</p> <p>ATTIC VENTILATION (15 CFM) WILL BE PROVIDED BY HRV-1 WITH A SUPPLY TO THE ATTIC AND A TRANSFER GRILLE AT OPPOSITE END TO LIVL 2 SPACE.</p> <p>PER M1503.6 KITCHEN HOOD IS 400CFM AND DUCTED TO EXTERIOR. MAKEUP AIR SYSTEM WILL BE PROVIDED VIA MAKEUP AIR SYSTEM (MAS-1) LOCATED IN NORTH CRAWLSPACE TO LIMIT NEGATIVE PRESSURE WITHIN HOME. ROUTE DUCTS AS LOW AND CLOSE TO RANGE AS POSSIBLE.</p> <p>PER M1504.4 MINIMUM LOCAL MECH EXHAUST RATES AT KITCHEN = 100 CFM INTERMITTENT AND BATHROOM/TOILET ROOMS = 50 CFM INTERMITTENT. PROVIDE HRV BOOST WITH "RTS3 2040(60) PUSH BUTTON TIMER" AT EACH BATHROOM)</p> <p>WATER HEATER: NIA TIER III STAND-ALONE HYBRID HEAT PUMP WATER HEATER (HPWH-1) LOCATED IN SOUTH CRAWLSPACE.</p> <p>ELECTRICAL: 320 AMP SERVICE LOCATED IN GARAGE ELECTRICAL CONTRACTOR SHALL BE RESPONSIBLE FOR ALL ELECTRICAL PERMITTING</p> <p>LIGHTING EQUIPMENT: NOT LESS THAN 90 PERCENT OF THE PERMANENTLY INSTALLED LIGHTING FIXTURES SHALL CONTAIN ONLY HIGH-EFFICIENCY LAMPS PER IRC N1104.1 (R404.1)</p> <p>PROGRAMMABLE THERMOSTAT: THE THERMOSTAT CONTROLLING THE PRIMARY HEATING OR COOLING SYSTEM OF THE DWELLING UNIT SHALL BE CAPABLE OF CONTROLLING THE HEATING AND COOLING SYSTEM ON A DAILY SCHEDULE TO MAINTAIN DIFFERENT TEMPERATURE SET POINTS AT DIFFERENT TIMES OF DAY. THIS THERMOSTAT SHALL INCLUDE CAPABILITY TO OPERATE THE SYSTEM TO MAINTAIN ZONE TEMPERATURES OF NOT LESS THAN 55°F TO NOT GREATER THAN 85°F PER IRC N1103.1.1 (R403.1.1).</p> <p>SOLAR: PROVIDE CONDUIT STUB OUT AT ROOF FOR FUTURE PV. COORDINATE LOCATION WITH ARCHITECT PRIOR TO INSTALLATION</p>																																																																																																																				

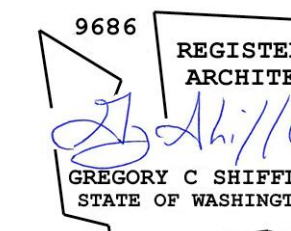

CONTACT
SHED ARCHITECTURE & DESIGN
1401 S JACKSON ST
SEATTLE, WA 98144
206.320.8700

PROJECT
SULLIVAN
3024 69th Ave SE
MERCER ISLAND, WA 98040

ISSUE	DATE
PRE APP #1 (PRE22-0433)	2022.08.16
CAR 2 (CA022-023)	2022.12.08
PERMIT SET	2023.01.20
REVISION #1	2023.05.26
REVISION #2	2023.07.07

DRAWING TITLE
COVER SHEET

G-000

BOUNDARY AND TOPOGRAPHIC SURVEY

A PORTION OF THE SOUTHWEST QUARTER OF THE NORTHWEST QUARTER
SECTION 12, TOWNSHIP 24 NORTH, RANGE 04 EAST, W.M.,
CITY OF MERCER ISLAND, KING COUNTY, WASHINGTON

LEGAL DESCRIPTION:

TAX PARCEL NUMBER 217510-0330-04:
LOTS 20, 21 AND 22, BLOCK 40, EAST SEATTLE BLOCKS 39 & 40, ACCORDING TO THE PLAT THEREOF RECORDED IN VOLUME 4 OF PLATS, PAGE 21, RECORDS OF KING COUNTY, WASHINGTON.

TAX PARCEL NUMBER 217510-0315-03:
LOTS 17, 18 AND 19, BLOCK 40, EAST SEATTLE BLOCKS 39 & 40, ACCORDING TO THE PLAT THEREOF RECORDED IN VOLUME 4 OF PLATS, PAGE 21, RECORDS OF KING COUNTY, WASHINGTON.

ALL SITUATE IN THE COUNTY OF KING, STATE OF WASHINGTON.

TITLE RESTRICTIONS:

TAX PARCEL NUMBER 217510-0330-04:

- THIS SITE IS SUBJECT TO COVENANTS, CONDITIONS, RESTRICTIONS, RECITALS, RESERVATIONS, EASEMENTS, EASEMENT PROVISIONS, DEDICATIONS, BUILDING SETBACK LINES, NOTES, STATEMENTS, AND OTHER MATTERS, IF ANY, BUT OMITTING ANY COVENANTS OR RESTRICTIONS, IF ANY, INCLUDING BUT NOT LIMITED TO THOSE BASED UPON RACE, COLOR, RELIGION, SEX, SEXUAL ORIENTATION, FAMILIAL STATUS, MARITAL STATUS, DISABILITY, HANDICAP, NATIONAL ORIGIN, ANCESTRY, OR SOURCE OF INCOME, AS SET FORTH IN APPLICABLE LAW, AS SET FORTH ON THE PLAT OF EAST SEATTLE BLOCKS 39 & 40, RECORDING NUMBER 40295.
- THIS SITE IS SUBJECT TO A 5' SIDE SEWER EASEMENT, AS DISCLOSED BY DOCUMENT RECORDED UNDER RECORDING NUMBER 8811301386. THIS EASEMENT CONTAINS A PROVISION FOR BEARING A PROPORTIONATE OR EQUAL COST OF MAINTENANCE, REPAIR OR RECONSTRUCTION OF SAID SIDE SEWER BY THE COMMON USERS. EASEMENT OVER PIPE AS CONSTRUCTED; NOT SHOWN HEREON.
- THIS SITE IS SUBJECT TO RESERVATIONS AND EXCEPTIONS IN UNITED STATES PATENTS OR IN ACTS AUTHORIZING THE ISSUANCE THEREOF; INDIAN TREATY OR ABORIGINAL RIGHTS.
- THIS SITE IS SUBJECT TO CITY, COUNTY OR LOCAL IMPROVEMENT DISTRICT ASSESSMENTS, IF ANY.
- THIS SITE IS SUBJECT TO ANY UNRECORDED LEASEHOLDS, RIGHT OF VENDORS AND HOLDERS OF SECURITY INTERESTS ON PERSONAL PROPERTY INSTALLED UPON THE LAND AND RIGHTS OF TENANTS TO REMOVE TRADE FIXTURES AT THE EXPIRATION OF THE TERMS.

TAX PARCEL NUMBER 217510-0315-03:

- THIS SITE IS SUBJECT TO COVENANTS, CONDITIONS, RESTRICTIONS, RECITALS, RESERVATIONS, EASEMENTS, EASEMENT PROVISIONS, DEDICATIONS, BUILDING SETBACK LINES, NOTES, STATEMENTS, AND OTHER MATTERS, IF ANY, BUT OMITTING ANY COVENANTS OR RESTRICTIONS, IF ANY, INCLUDING BUT NOT LIMITED TO THOSE BASED UPON RACE, COLOR, RELIGION, SEX, SEXUAL ORIENTATION, FAMILIAL STATUS, MARITAL STATUS, DISABILITY, HANDICAP, NATIONAL ORIGIN, ANCESTRY, OR SOURCE OF INCOME, AS SET FORTH IN APPLICABLE LAW, AS SET FORTH ON THE PLAT OF EAST SEATTLE BLOCKS 39 & 40, RECORDING NUMBER 40295.
- THIS SITE IS SUBJECT TO AN EASEMENT GRANTED TO MERCER ISLAND SEWER DISTRICT FOR SEWER, RECORDED UNDER RECORDING NUMBER 4635710. THIS EASEMENT IS SHOWN HEREON.
- THIS SITE IS SUBJECT TO CITY, COUNTY OR LOCAL IMPROVEMENT DISTRICT ASSESSMENTS, IF ANY.

SURVEYOR'S NOTES

- ALL TITLE INFORMATION SHOWN ON THIS MAP HAS BEEN EXTRACTED FROM FIDELITY NATIONAL TITLE COMPANY OF WASHINGTON, COMMITMENTS NO. 611287325, DATED MAY 10, 2021 AND NO. 611287326, DATED MAY 12, 2021. IN PREPARING THIS MAP, D.R. STRONG CONSULTING ENGINEERS INC. HAS CONDUCTED NO INDEPENDENT TITLE SEARCH NOR IS D.R. STRONG CONSULTING ENGINEERS INC. AWARE OF ANY TITLE ISSUES AFFECTING THE SURVEYED PROPERTY OTHER THAN THOSE SHOWN ON THE MAP AND DISCLOSED BY REFERENCED FIDELITY NATIONAL TITLE COMPANY COMMITMENTS. D.R. STRONG CONSULTING ENGINEERS INC. HAS RELIED WHOLLY ON FIDELITY NATIONAL TITLE COMPANY REPRESENTATIONS OF THE TITLE'S CONDITION TO PREPARE THIS SURVEY AND THEREFORE D.R. STRONG CONSULTING ENGINEERS INC. QUALIFIES THE MAP'S ACCURACY AND COMPLETENESS TO THAT EXTENT.
- THIS SURVEY REPRESENTS VISIBLE PHYSICAL IMPROVEMENT CONDITIONS EXISTING ON MAY 14 AND 17, 2021. ALL SURVEY CONTROL INDICATED AS "FOUND" WAS RECOVERED FOR THIS PROJECT ON MAY 14 AND 17, 2021.
- PROPERTY AREA = 17,300± SQUARE FEET (0.397± ACRES).
- ALL DISTANCES ARE IN U.S. SURVEY FEET.
- THIS IS A COMBINED FIELD TRAVERSE AND GLOBAL POSITIONING SYSTEM SURVEY. A TRIMBLE ONE-SECOND COMBINED ELECTRONIC TOTAL STATION AND A TRIMBLE R12 GLOBAL POSITIONING SYSTEM WERE USED TO MEASURE THE ANGULAR AND DISTANCE RELATIONSHIPS BETWEEN THE CONTROLLING MONUMENTATION AS SHOWN, UTILIZING RTK OBSERVATIONS USING THE WSRN. CLOSURE RATIOS OF THE TRAVERSE MET OR EXCEEDED THOSE SPECIFIED IN WAC 332-130-090. ALL MEASURING INSTRUMENTS AND EQUIPMENT ARE MAINTAINED IN ADJUSTMENT ACCORDING TO MANUFACTURER'S SPECIFICATIONS.
- UTILITIES OTHER THAN THOSE SHOWN MAY EXIST ON THIS SITE. ONLY THOSE UTILITIES WITH EVIDENCE OF THEIR INSTALLATION VISIBLE AT GROUND SURFACE ARE SHOWN HEREON. UNDERGROUND UTILITY LOCATIONS SHOWN ONLY. UNDERGROUND CONNECTIONS ARE SHOWN AS STRAIGHT LINES BETWEEN SURFACE UTILITY LOCATIONS BUT MAY CONTAIN BENDS OR CURVES NOT SHOWN. SOME UNDERGROUND LOCATIONS SHOWN HEREON MAY HAVE BEEN TAKEN FROM PUBLIC RECORDS. D.R. STRONG CONSULTING ENGINEERS INC. ASSUMES NO LIABILITY FOR THE ACCURACY OF PUBLIC RECORDS.
- CONTOUR INTERVAL = 2 FOOT. CONTOURS SHOWN ARE PRODUCED FROM A DIGITAL TERRAIN MODEL DERIVED FROM DIRECT FIELD OBSERVATIONS OBTAINED DURING THE COURSE OF THE FIELD TRAVERSE SURVEY. CONTOUR ACCURACY COMPLIES WITH NATIONAL MAP ACCURACY STANDARDS (AT LEAST 90 PERCENT OF THE ELEVATIONS ACCURATE WITHIN ONE-HALF THE CONTOUR INTERVAL).
- THE PURPOSE OF THIS SURVEY REVISION WAS TO DEPICT THE LOCATION OF THE SIDE SEWER, RECENTLY PAINTED BY A LOCATE COMPANY, FOR THE NEW OWNER OF TAX PARCEL 217510-0315. PAINT MARKS WERE PLACED NEAR THE SOUTH LINES OF TAX PARCELS 217510-0315 & 217510-0330. THE UNDERLYING SURVEY REPRESENTS THE SAME BOUNDARY AND TOPOGRAPHIC SURVEY BY D.R. STRONG CONSULTING ENGINEERS, PROJECT NUMBER 21065, REVISION DATE 7/7/2022 FOR JANET CASAL. FIELD MAPPING OF THE UTILITY PAINT MARKS TOOK PLACE ON 4/19/2023.

REFERENCES:

- (P) PLAT OF EAST SEATTLE BLOCKS 39 & 40, VOLUME 4, PAGE 21
- (R1) RECORD OF SURVEY, RECORDING NO. 20091020900014
- (R2) RECORD OF SURVEY, RECORDING NO. 20191115900004
- (R3) RECORD OF SURVEY, RECORDING NO. 20080415900004
- (R4) RECORD OF SURVEY, RECORDING NO. 20171015900001

HORIZONTAL DATUM:

NAD83-2011 EPOCH 2010.00 WASHINGTON PLANE COORDINATE SYSTEM - NORTH ZONE

VERTICAL DATUM:

NAVD88 PER GPS OBSERVATIONS

BENCHMARK:

REBAR AND CAP SET 2.00' EAST OF THE EAST EDGE OF PAVEMENT ON 70TH AVENUE SE ACROSS THE STREET FROM THE NORTHEAST CORNER OF HOUSE 3015; 22.00' EAST OF POWER POLE 221604-165197 ELEVATION DETERMINED BY GPS OBSERVATION = 283.43'

LEGEND:

- FOUND SECTION CORNER AS NOTED
- FOUND QUARTER CORNER AS NOTED
- FOUND MONUMENT AS NOTED
- FOUND CORNER MONUMENT AS NOTED
- FOUND PK NAIL AND WASHER AS NOTED
- MAIL BOX
- POWER METER
- POWER POLE
- WATER METER
- WATER VALVE
- WATER SPIGOT
- FIRE HYDRANT
- STORM DRAIN CATCH BASIN
- SANITARY SEWER MANHOLE
- GAS VALVE
- VERTICAL BOARD FENCE
- HORIZONTAL BOARD FENCE
- CHAINLINK FENCE
- WROUGHT IRON FENCE
- ROCKERY
- DECIDUOUS TREE
- EVERGREEN TREE
- SANITARY SEWER LINE
- STORM LINE
- OVERHEAD POWER
- UNDERGROUND WATER
- EDGE OF PAVEMENT
- FENCE
- CONCRETE

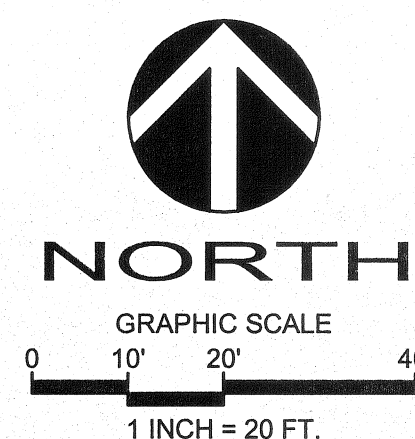

BASIS OF BEARINGS:

NORTH 88°49'27" WEST BETWEEN THE MONUMENTS FOUND IN PLACE ALONG SE 32ND STREET, PER GPS OBSERVATIONS

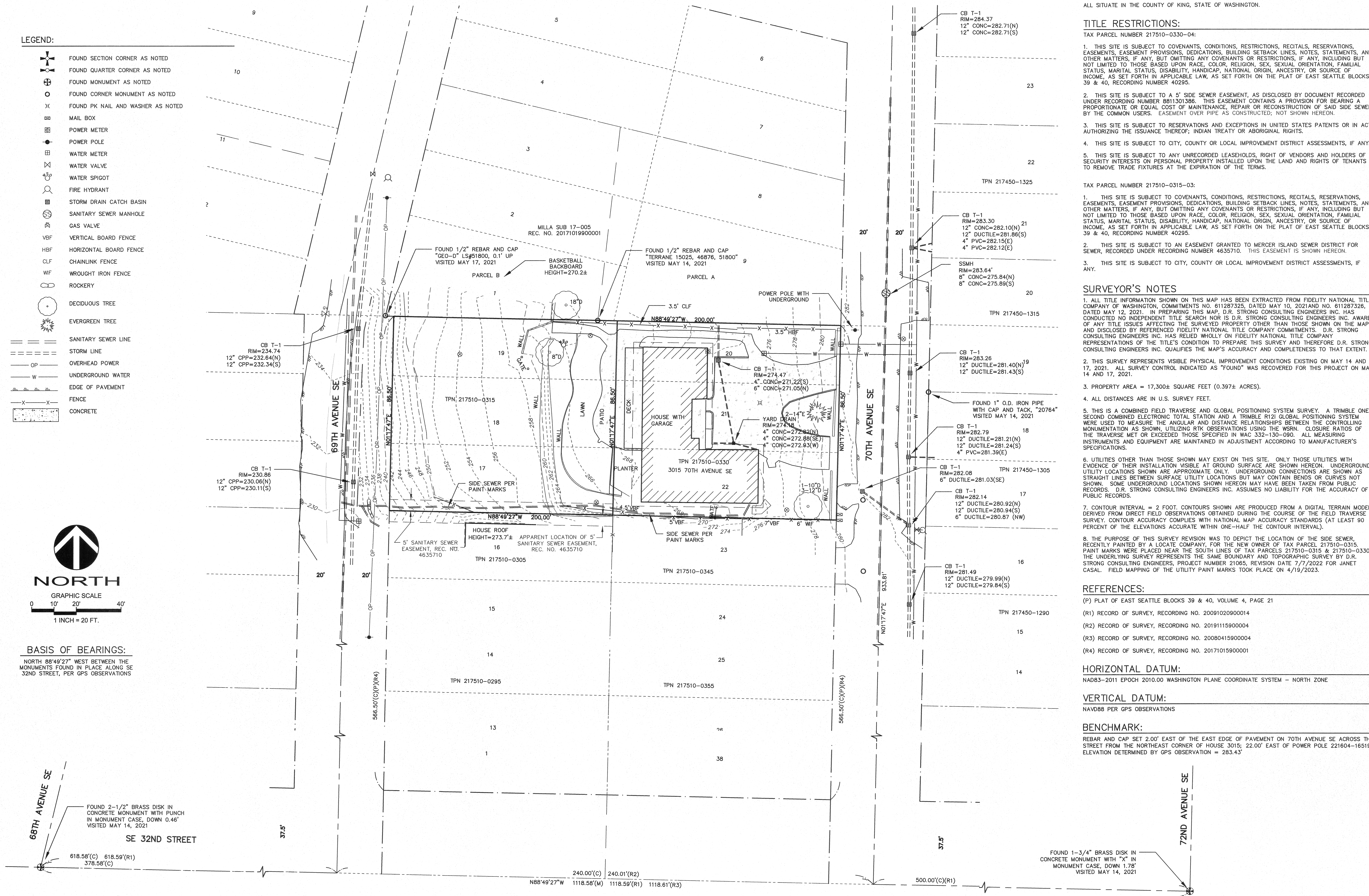

D.R. STRONG
CONSULTING ENGINEERS
ENGINEERS PLANNERS SURVEYORS
620 - 7th AVENUE KIRKLAND, WA 98033
O 425.827.3063 F 425.827.2423

BOUNDARY AND TOPOGRAPHIC SURVEY

3015 70TH AVENUE SE
AND 30XX 69TH AVENUE SE
TAX PARCEL NUMBERS
217510-0315-03 AND 217510-0330-04
CITY OF MERCER ISLAND, WASHINGTON

JOHN SULLIVAN
C/O SHED ARCHITECTURE

1401 S. JACKSON ST.
SEATTLE, WA 98144

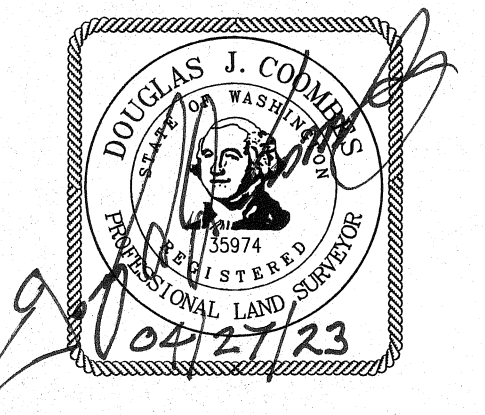

APR	D/C
REVISION	ADDED SIDE SEWER
DATE	4/27/2023

PROJECT SURVEYOR: JMS
DRAFTED BY: JMS/DLC
FIELD BOOK: 199 B & D
DATE: 04/27/2023
PROJECT NO.: 23031

SHEET: 1 OF 1

NO STAGING OR STORAGE WITHIN RIGHT-OF-WAY
ALL STAGING AND STORAGE TO TAKE PLACE WITHIN LIMITS OF WORK

CONSTRUCTION ENTRANCE PER BMP C105

INSTALL STORM DRAIN INLET PROTECTION PER BMP C200

SILT FENCE AND HI-VIZ LIMIT OF WORK FENCE PER BMP C233 AND BMP C103

PROTECT TREES BEYOND LIMITS OF WORK (TYP.)

REMOVE TREE (TYP.)

CONSTRUCTION FENCE ALONG THE EDGE OF SEWER EASEMENT
ALL WORK PERFORMED IN THE EASEMENT SHALL BE COMPLETED BY HAND UNLESS OTHERWISE APPROVED BY CITY ENGINEER. NO HEAVY EQUIPMENT SHALL CROSS THE TEMPORARY CONSTRUCTION FENCE OR INTO THE EASEMENT AREA

- CONSTRUCTION SEQUENCE:**
- HOLD ON-SITE PRE-CONSTRUCTION MEETING.
 - FLAG OR FENCE CLEARING LIMITS
 - CONSTRUCTION FENCE SHALL BE SET ALONG THE ENTIRE LENGTH OF THE NORTH EDGE OF THE SEWER EASEMENT WITHIN PROPERTY LIMITS TO PROTECT THE EXISTING SEWER MAIN. FENCE SHALL REMAIN AND BE IDENTIFIED FOR THE DURATION OF CONSTRUCTION. ALL WORK WITHIN THE PUBLIC SEWER EASEMENT SHALL BE COMPLETED BY HAND TO PROTECT THE SEWER MAIN, UNLESS OTHERWISE APPROVED BY THE CITY ENGINEER. NO HEAVY EQUIPMENT SHALL CROSS THE TEMPORARY CONSTRUCTION FENCE OR INTO THE EASEMENT AREA.
 - INSTALL STORM DRAIN INLET PROTECTION AS INDICATED
 - GRADE AND INSTALL CONSTRUCTION ENTRANCE PER CITY STANDARDS
 - INSTALL PERIMETER PROTECTION
 - MAINTAIN EROSION CONTROL MEASURES IN ACCORDANCE WITH CITY STANDARDS AND THOSE LAID OUT IN GEOTECHNICAL REPORT
 - TEMPORARY AND PERMANENT SHORING INSTALLED PER STRUCTURAL AND GEOTECH
 - EXCAVATION FOR FOUNDATION, ALL WORK SHALL BE PERFORMED IN ACCORDANCE WITH CITY STANDARDS AND THE PROJECT GEOTECHNICAL REPORT BY COBALT GEOSCIENCES.
 - RELOCATE TESC MEASURES, OR INSTALL NEW MEASURES SO THAT AS SITE CONDITIONS CHANGE, THE TESC IS ALWAYS IN ACCORDANCE WITH CITY OF MERCER ISLAND TESC REQUIREMENTS
 - COVER ALL AREAS THAT WILL BE UN-WORKED FOR MORE THAN SEVEN DAYS DURING THE DRY-SEASON (MAY 1 TO SEPT 30) OR FOR TWO DAYS DURING THE WET SEASON (OCT 1 TO APRIL 30) WITH STRAW, WOOD FIBER MULCH, COMPOST, PLASTIC SHEETING, OR EQUIVALENT
 - STABILIZE ALL AREAS WITHIN SEVEN DAYS OF REACHING FINAL GRADE
 - STABILIZE OR COVER ANY AREAS TO REMAIN UNWORKED FOR MORE THAN 30 DAYS MER GEOTECHNICAL REPORT
 - UPON COMPLETION OF THE PROJECT, STABILIZE ALL DISTURBED AREAS AND REMOVE BMPs IF APPROPRIATE

- NOTES:**
- PRESENCE OF THE GEOTECHNICAL ENGINEER IS REQUIRED ON SITE TO PROVIDE DAILY OBSERVATION OF ACTIVITIES AND SLOPES DURING THE INITIAL EXCAVATION AND SUBSEQUENTLY DURING THE COURSE OF CONSTRUCTION AT LEAST ONCE A WEEK AND AFTER SIGNIFICANT RAINFALL EVENTS. FIELD REPORT OF THESE SITE VISITS SHOULD BE SENT TO THE CITY OF MERCER ISLAND (INSPECTIONREPORTS@MERCERGOV.ORG).

SEE C2 FOR DRAINAGE SITE PLAN

Sullivan Residence
Site Address: 3024 69th Ave SE
Jurisdiction: Mercer Island
Parcel No.: 217510-0315
Applicant: SHED
Permit No.: 2301-185
Interlaken Project No.: SEA-22-137



Interlaken Engineering and Design, PLLC
Seattle, WA | (206) 470-9572
www.interlakenengineering.com

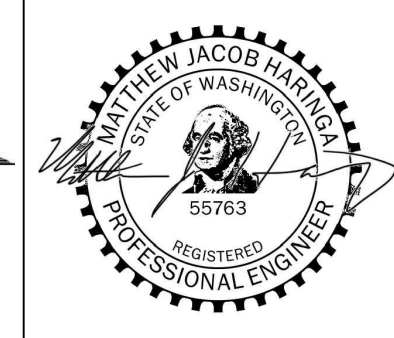

Revisions:
2023-07-07: Updated for City of Mercer Island comments
2023-05-26: Updated for City of Mercer Island comments

C1
TESC/ Demo/ CSWPPP
Scale: 1" = 10'

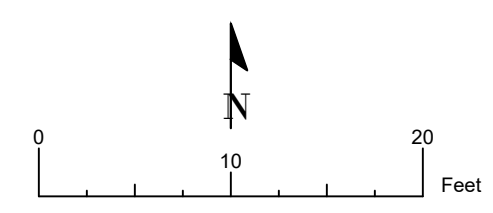

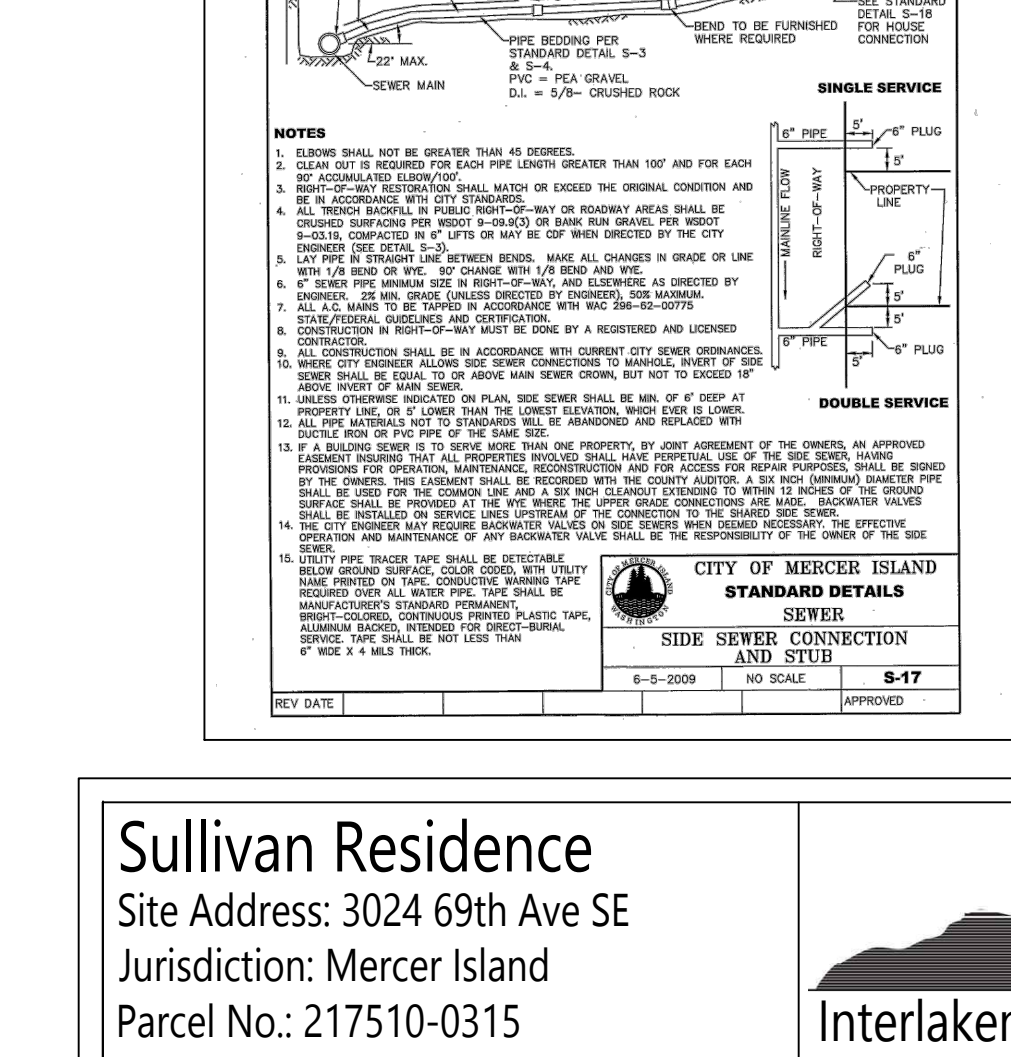
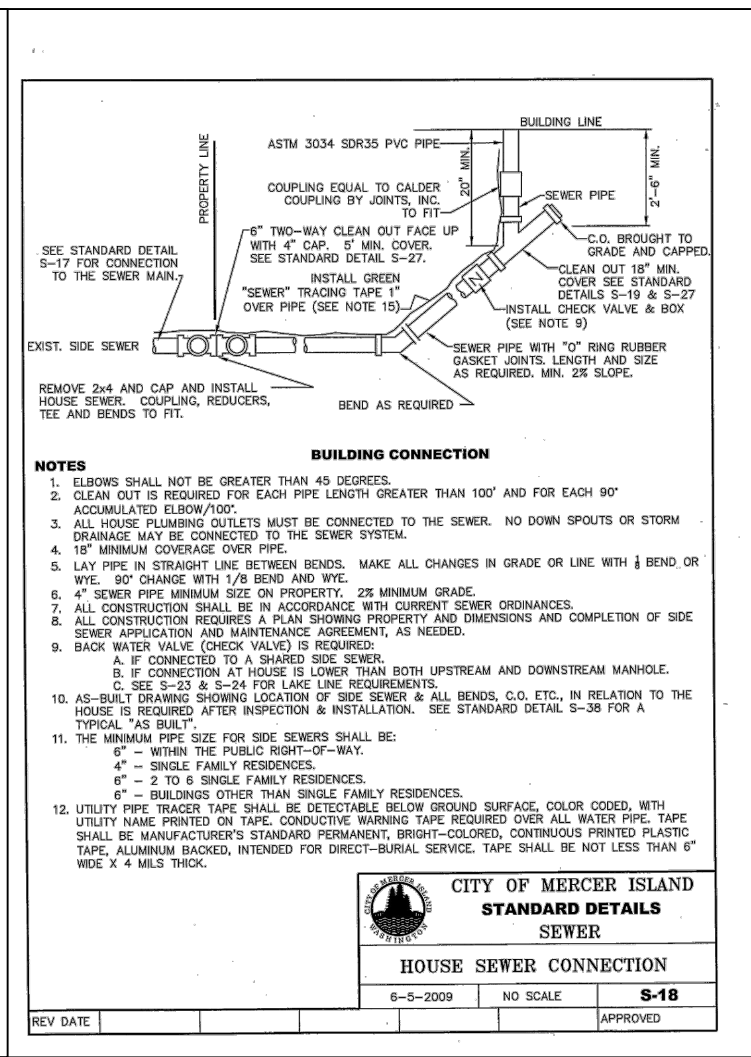
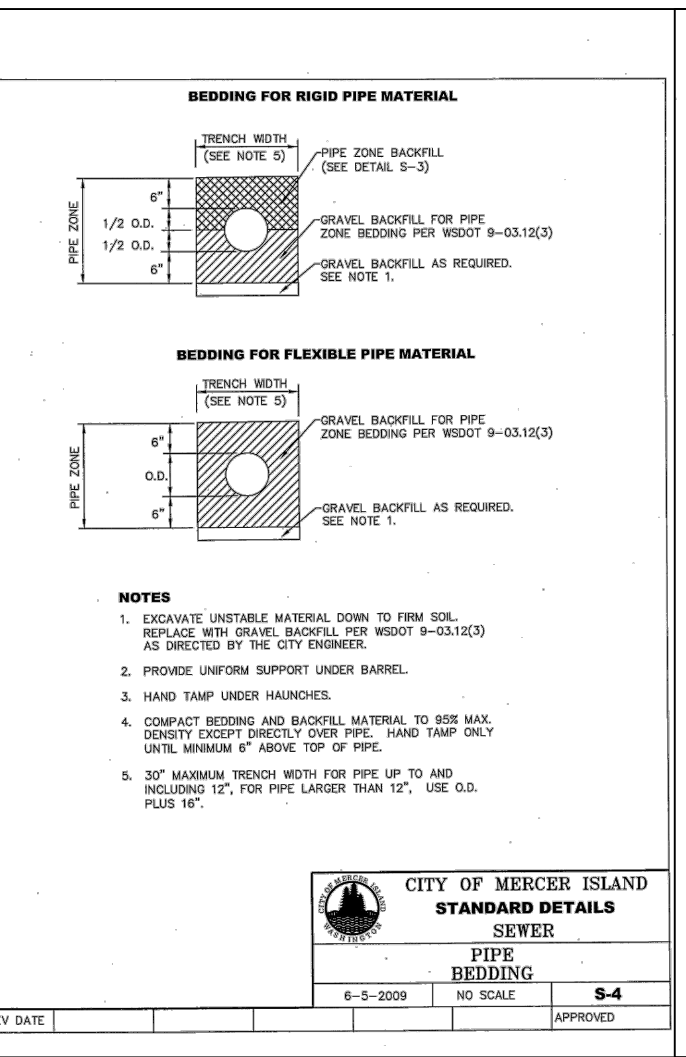
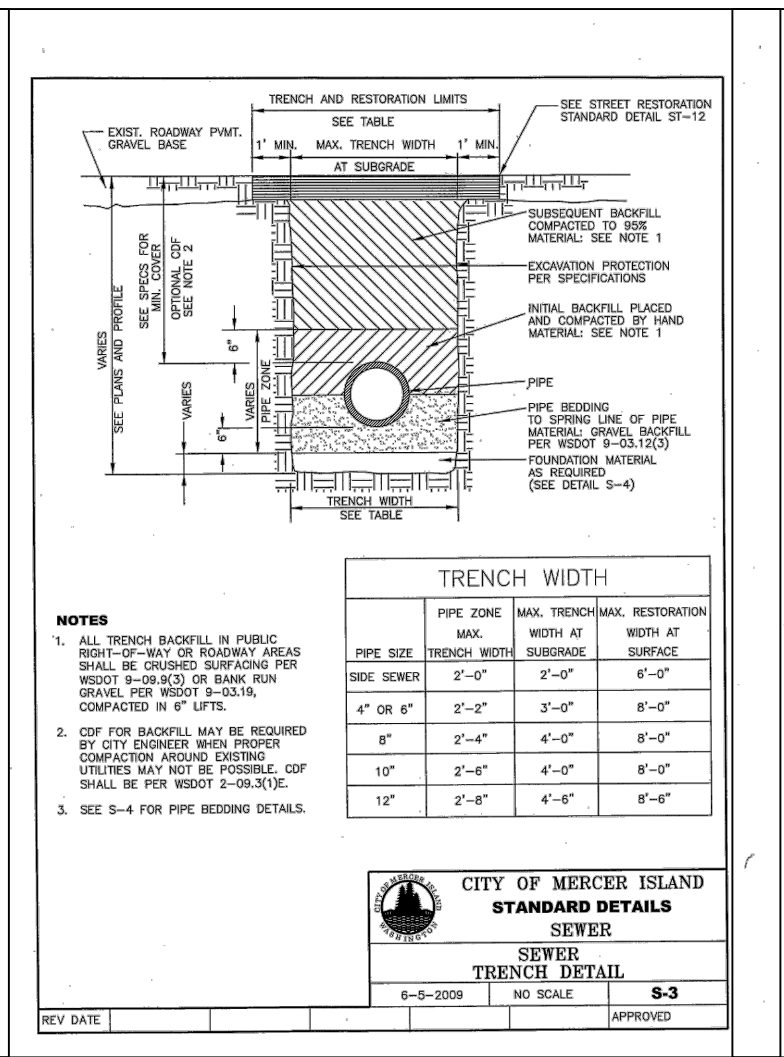
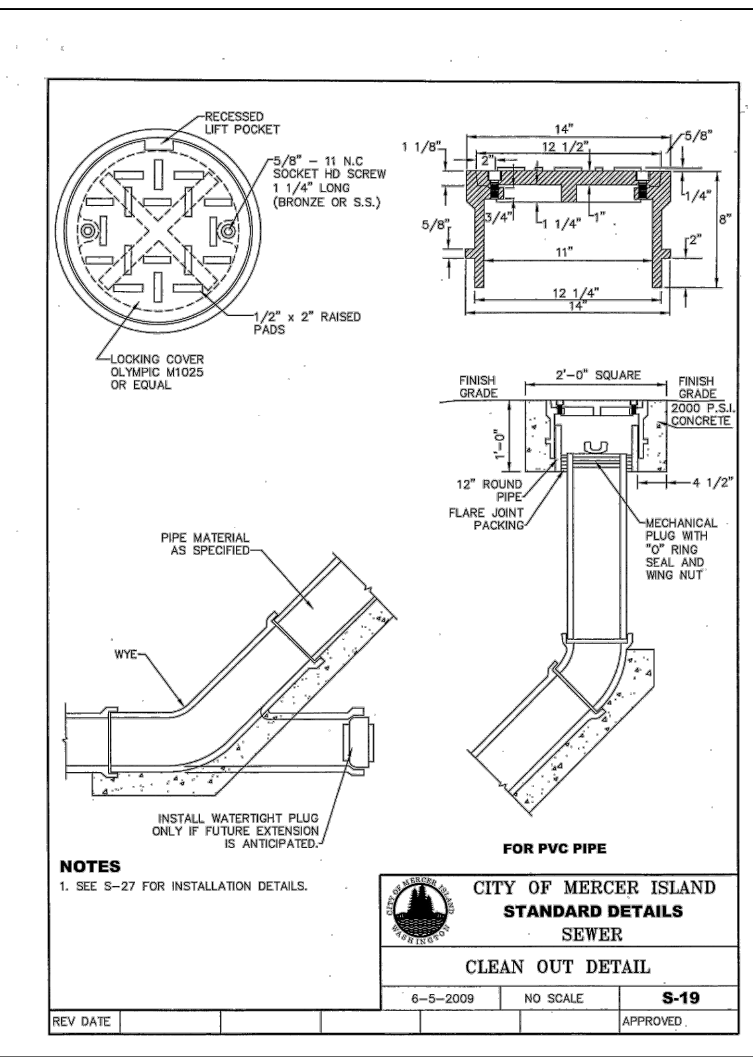
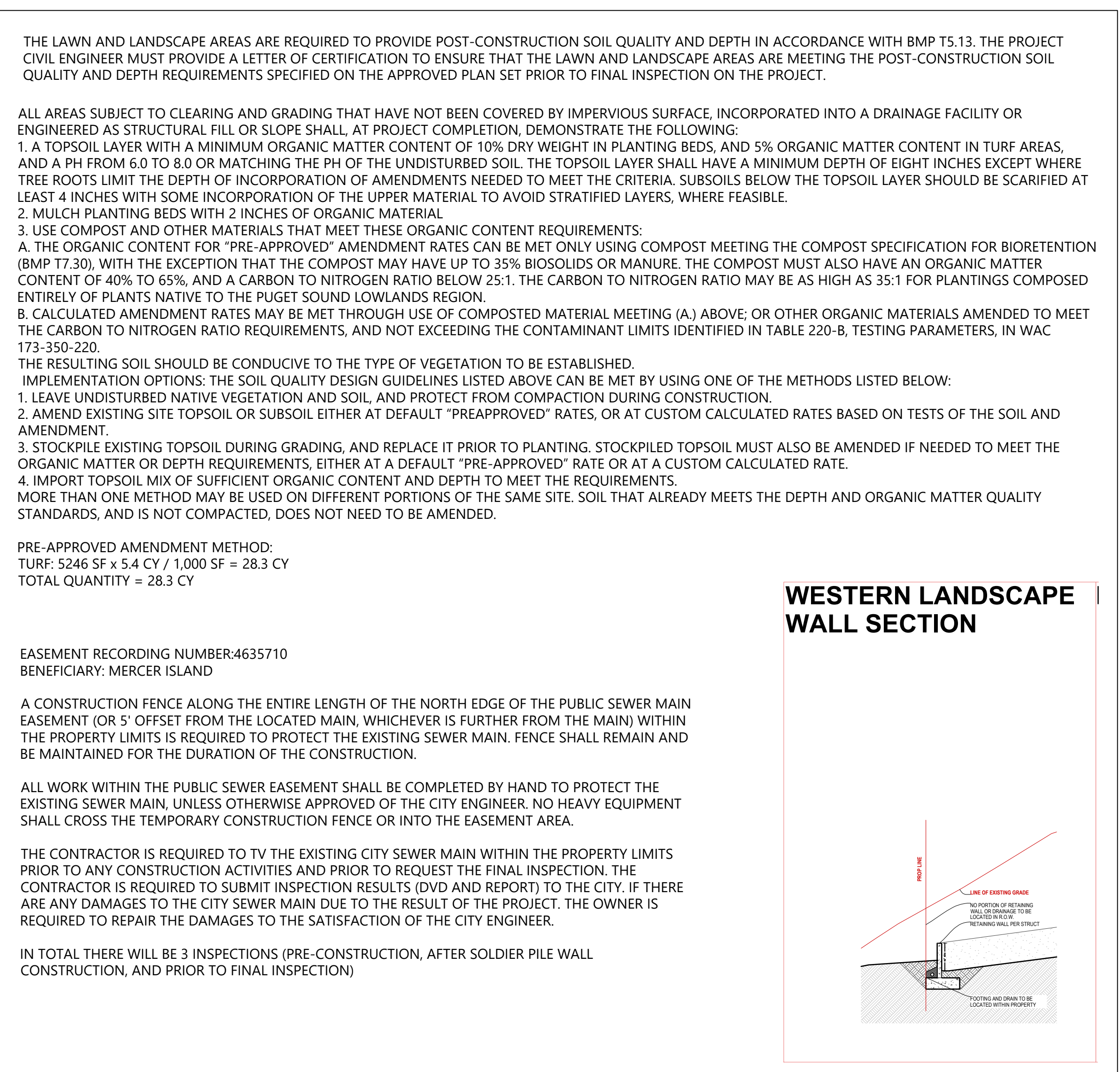
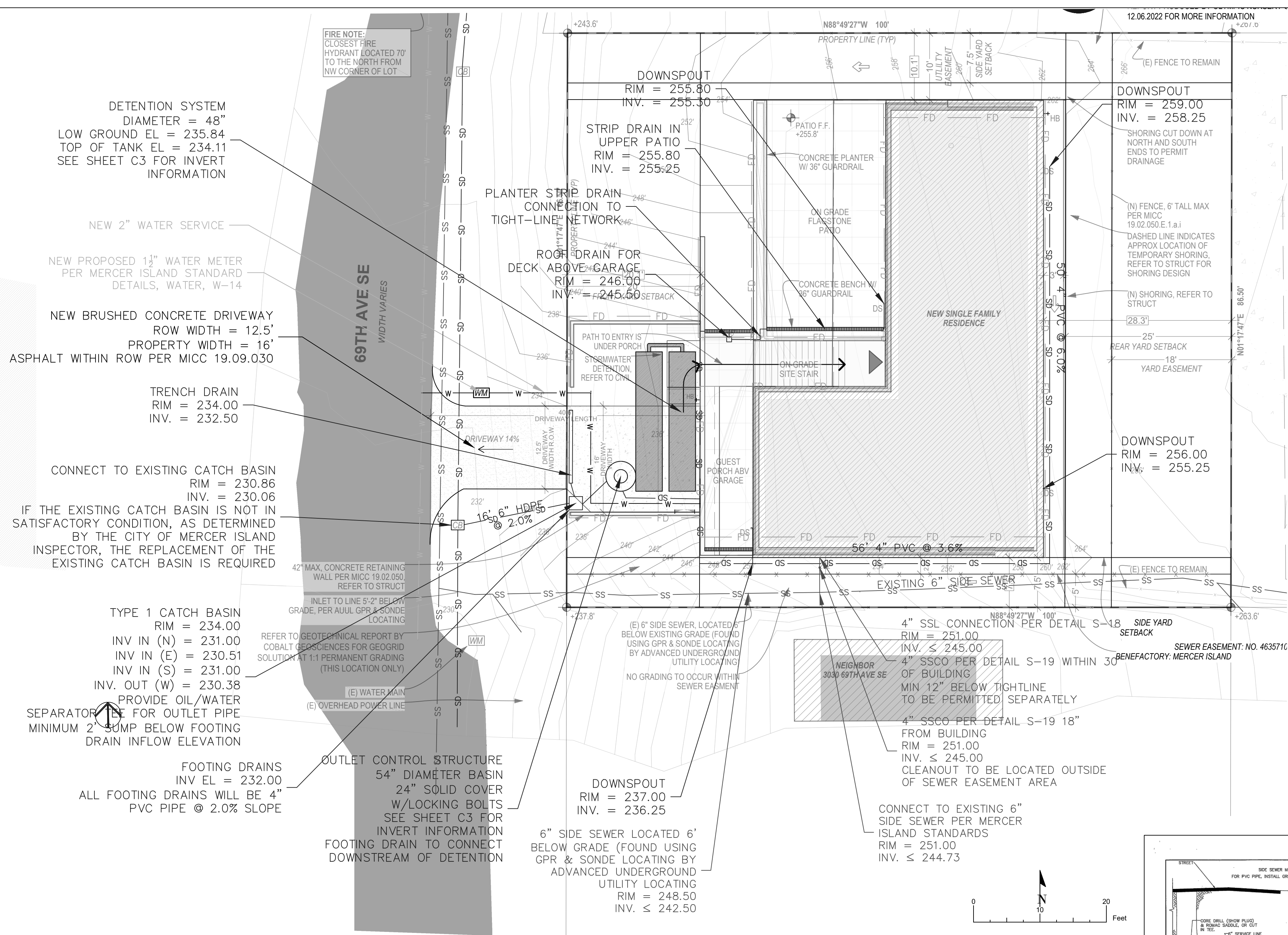

Sullivan Residence
 Site Address: 3024 69th Ave SE
 Jurisdiction: Mercer Island
 Parcel No.: 217510-0315
 Applicant: SHED
 Permit No.: 2301-185
 Interlaken Project No.: SEA-22-137

Interlaken Engineering and Design, PLLC
 Seattle, WA | (206) 470-9572
 www.interlakenengineering.com



Revisions:
 2023-07-07: Updated for City of Mercer Island comments
 2023-05-26: Updated for City of Mercer Island comments

C2
 Drainage Site Plan
 Scale: 1" = 10'

ATTACHMENT 1
CITY OF MERCER ISLAND
ON-SITE DETENTION SYSTEM WORKSHEET
(FOR NEW PLUS REPLACED IMPERVIOUS
AREA OF 9,500 SF OR LESS)

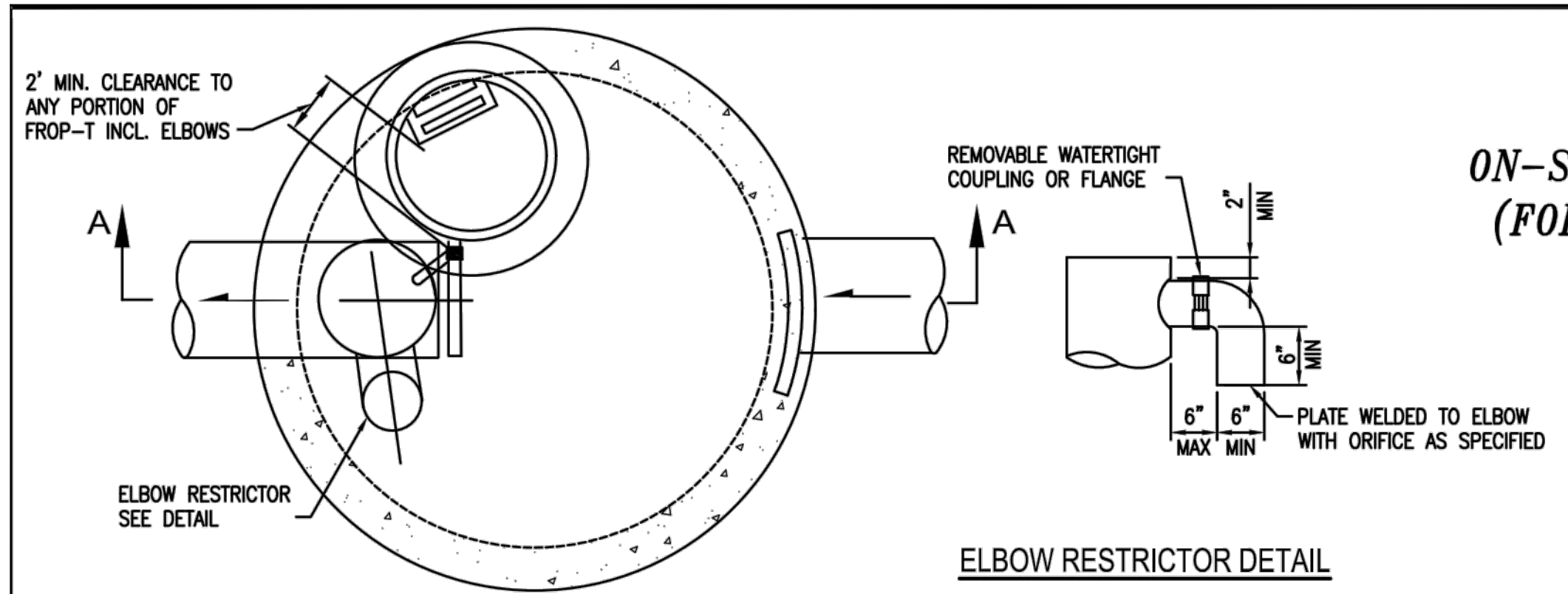

ELBOW RESTRICTOR DETAIL

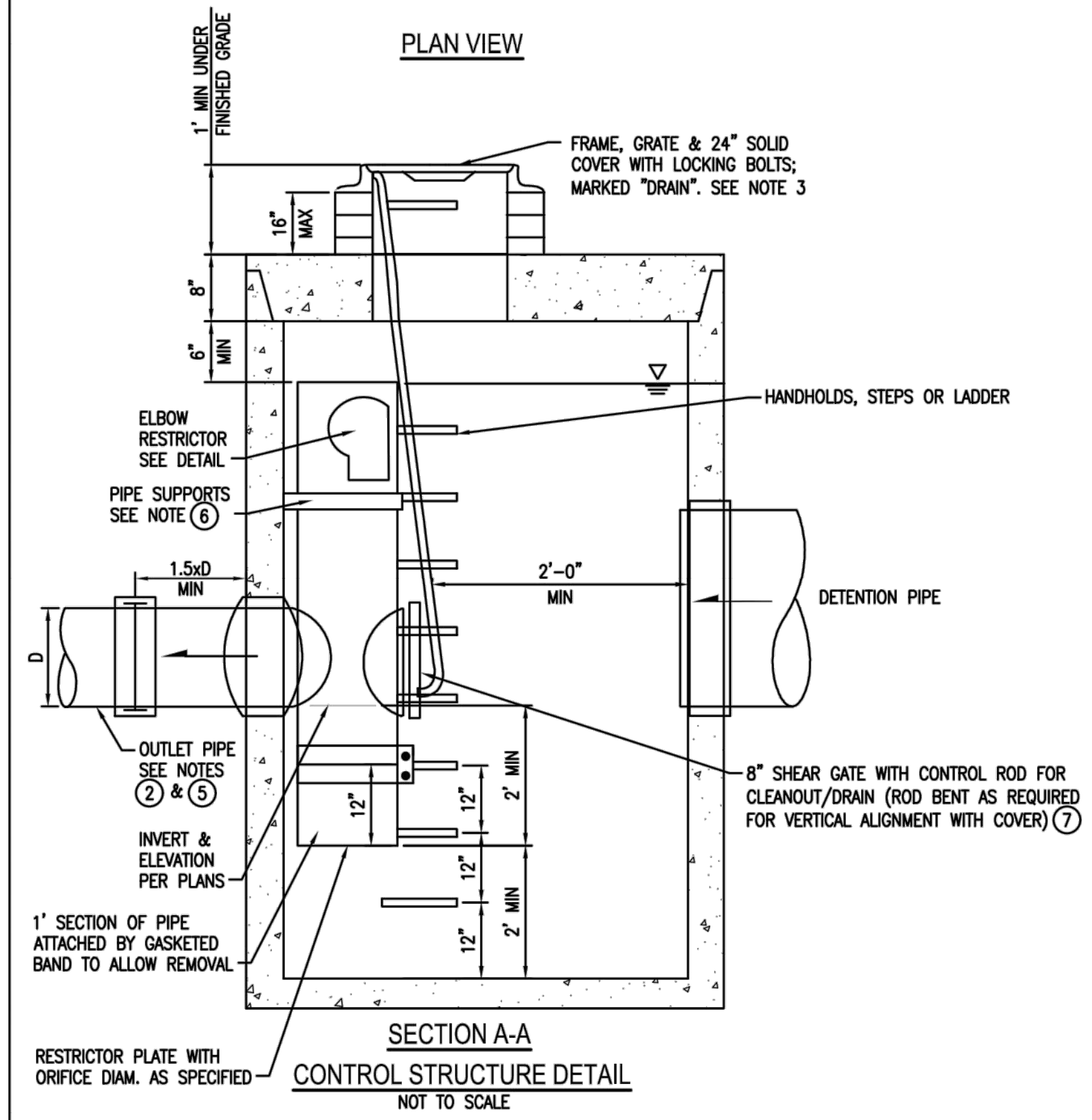

SECTION A-A
CONTROL STRUCTURE DETAIL
 NOT TO SCALE

OWNER: <u>John Sullivan</u>	ADDRESS: <u>3024 69th Ave SE</u>	PREPARED BY: <u>Interlaken Engineering and Design, PLLC</u>
PERMIT #:		PHONE: <u>(206) 470-9572</u>
		DATE: <u>January 18, 2023</u>
NEW PLUS REPLACED IMPERVIOUS SURFACE AREA (SF): <u>3255 sf (roof) to be detained</u>	DETENTION PIPE DIA (INCH): <u>48</u>	DETENTION PIPE LENGTH (FT): <u>42</u>
SOIL TYPE: <u>C</u>	PIPE MATERIAL: <u>ADS</u>	ORIFICE #1 DIA <u>0.5</u> INCH, ELEV <u>228.61</u>
		ORIFICE #2 DIA <u>1.3</u> INCH, ELEV <u>233.86</u>

NO UPPER CATCH BASIN REQUIRED -
 DETENTION PIPE LENGTH IS LESS THAN 50 FT.

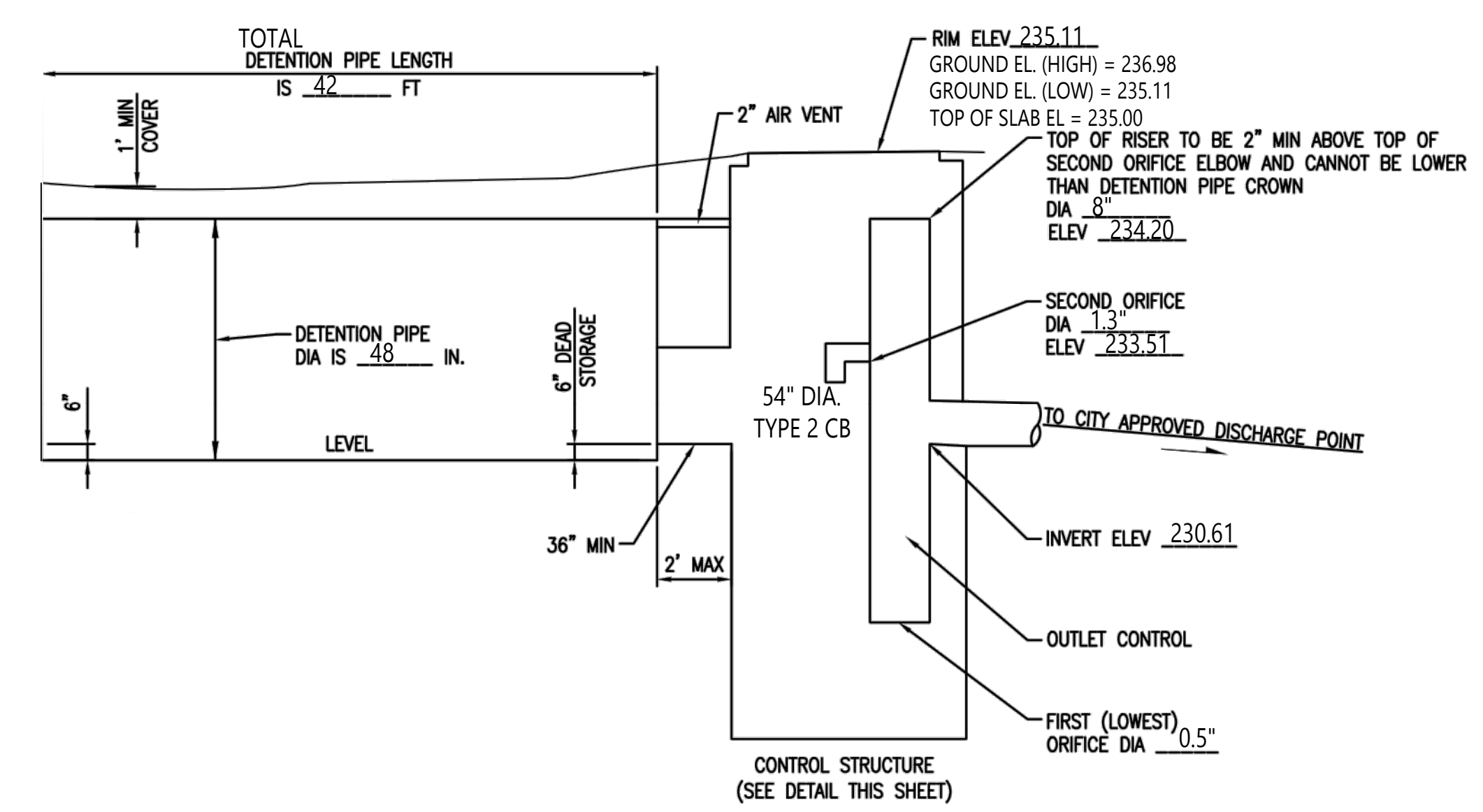

ON-SITE DETENTION SYSTEM
 NOT TO SCALE (ENGINEER TO FILL IN BLANKS)

CONTROL STRUCTURE NOTES:

- | | |
|--------------------------------------------------------------------------------------------------------------------------------------------------------------------------------------------------------------------------------------------------------------------------------------------------------------------------------------------------------------------------------------------------------------------------------------------------------------------------------------------------------------------------------------------------------------------------------------------------------------------------------------------------------------------------------------|-----------------------------------------------------------------------------------------------------------------------------------------------------------------------------------------------------------------------------------------------------------------------------------------------------------------------------------------------------------------------------------------------------------------------------------------------------------------------------------------------------------------------------------------------------------------------------------------------------------------------------------------------------------------------------------------------------------------------------------------------------------------------------------------------------------------------------------------------------------------------------------------------------------------------------------------------------------------------------------------------|
| <p>① USE A MINIMUM OF A 54 IN. DIAM. TYPE 2 CATCH BASIN. THE ACTUAL SIZE IS DEPENDENT ON CONNECTING PIPE MATERIAL AND DIAMETER.</p> <p>② OUTLET PIPE: MIN. 6 INCH.</p> <p>③ METAL PARTS: CORROSION RESISTANT. NON-GALVANIZED PARTS PREFERRED. GALVANIZED PIPE PARTS TO HAVE ASPHALT TREATMENT 1.</p> <p>④ FRAME AND LADDER OR STEPS OFFSET SO:
 A. CLEANOUT GATE IS VISIBLE FROM TOP;
 B. CLIMB-DOWN SPACE IS CLEAR OF RISER AND CLEANOUT GATE;
 C. FRAME IS CLEAR OF CURB.</p> <p>⑤ IF METAL OUTLET PIPE CONNECTS TO CEMENT CONCRETE PIPE, OUTLET PIPE TO HAVE SMOOTH O.D. EQUAL TO CONCRETE PIPE I.D. LESS 1/4 IN.</p> | <p>⑥ PROVIDE AT LEAST ONE 3 X 0.090 GAUGE SUPPORT BRACKET ANCHORED TO CONCRETE WALL WITH 5/8 IN. STAINLESS STEEL EXPANSION BOLTS OR EMBEDDED SUPPORTS 2 IN. INTO CATCH BASIN WALL (MAXIMUM 3'-0" VERTICAL SPACING).</p> <p>⑦ THE SHEAR GATE SHALL BE MADE OF ALUMINUM ALLOY IN ACCORDANCE WITH ASTM B 26M AND ASTM B 275, DESIGNATION ZG32A; OR CAST IRON IN ACCORDANCE WITH ASTM A 48, CLASS 30B. THE LIFT HANDLE SHALL BE MADE OF A SIMILAR METAL TO THE GATE (TO PREVENT GALVANIC CORROSION), IT MAY BE OF SOLID ROD OR HOLLOW TUBING, WITH ADJUSTABLE HOOK AS REQUIRED. A NEOPRENE RUBBER GASKET IS REQUIRED BETWEEN THE RISER MOUNTING FLANGE AND THE GATE FLANGE. INSTALL THE GATE SO THAT THE LEVEL-LINE MARK IS LEVEL WHEN THE GATE IS CLOSED. THE MATING SURFACES OF THE LID AND THE BODY SHALL BE MACHINED FOR PROPER FIT. ALL SHEAR GATE BOLTS SHALL BE STAINLESS STEEL.</p> <p>⑧ THE UPPER CATCH BASIN IS REQUIRED IF THE LENGTH OF THE DETENTION PIPE IS GREATER THAN 50 FT.</p> |
|--------------------------------------------------------------------------------------------------------------------------------------------------------------------------------------------------------------------------------------------------------------------------------------------------------------------------------------------------------------------------------------------------------------------------------------------------------------------------------------------------------------------------------------------------------------------------------------------------------------------------------------------------------------------------------------|-----------------------------------------------------------------------------------------------------------------------------------------------------------------------------------------------------------------------------------------------------------------------------------------------------------------------------------------------------------------------------------------------------------------------------------------------------------------------------------------------------------------------------------------------------------------------------------------------------------------------------------------------------------------------------------------------------------------------------------------------------------------------------------------------------------------------------------------------------------------------------------------------------------------------------------------------------------------------------------------------|

ON-SITE DETENTION SYSTEM NOTES:

- CALL DEVELOPMENT SERVICES (206-275-7605) 24 HOURS IN ADVANCE FOR A DETENTION SYSTEM INSPECTION BEFORE BACKFILLING AND FOR FINAL INSPECTIONS.
- RESPONSIBILITY FOR OPERATION AND MAINTANANCE OF DRAINAGE SYSTEMS ON PRIVATE PROPERTY IS RESPONSIBILITY OF THE PROPERTY OWNER. MATERIAL ACCUMULATED IN THE STORAGE PIPE MUST BE REMOVED FROM CATCH BASINS TO ALLOW PROPER OPERATION. THE OUTLET CONTROL ORIFICE MUST BE KEPT OPEN AT ALL TIMES.
- PIPE MATERIAL, JOINT, AND PROTECTIVE TREATMENT SHALL BE IN ACCORDANCE WITH SECTION 7.04 AND 9.05 OF THE WSDOT STANDARD SPECIFICATION FOR ROAD, BRIDGE, AND MUNICIPAL CONSTRUCTION, LATEST VERSION. SUCH MATERIALS INCLUDE THE FOLLOWING: LINED CORRUGATED POLYETHYLENE PIPE (LCPE), ALUMINIZED TYPE 2 CORRUGATED STEEL PIPE AND PIPE ARCH (MEETS AASHTO DESIGNATIONS M274 AND M36), CORRUGATED OR SPIRAL RIB ALUMINUM PIPE, OR REINFORCED CONCRETE PIPE. CORRUGATED STEEL PIPE IS NOT ALLOWED.
- FOOTING DRAINS SHALL NOT BE CONNECTED TO THE DETENTION SYSTEM.

SEE C2 FOR DRAINAGE SITE PLAN

Sullivan Residence
 Site Address: 3024 69th Ave SE
 Jurisdiction: Mercer Island
 Parcel No.: 217510-0315
 Applicant: SHED
 Permit No.: 2301-185
 Interlaken Project No.: SEA-22-137

Interlaken Engineering and Design, PLLC
 Seattle, WA | (206) 470-9572
 www.interlakenengineering.com

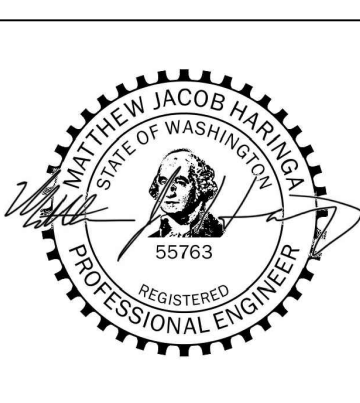

Revisions:
2023-07-07: Updated for City of Mercer Island comments
2023-05-26: Updated for City of Mercer Island comments

C3
 Detention Detail
 Scale: As Noted

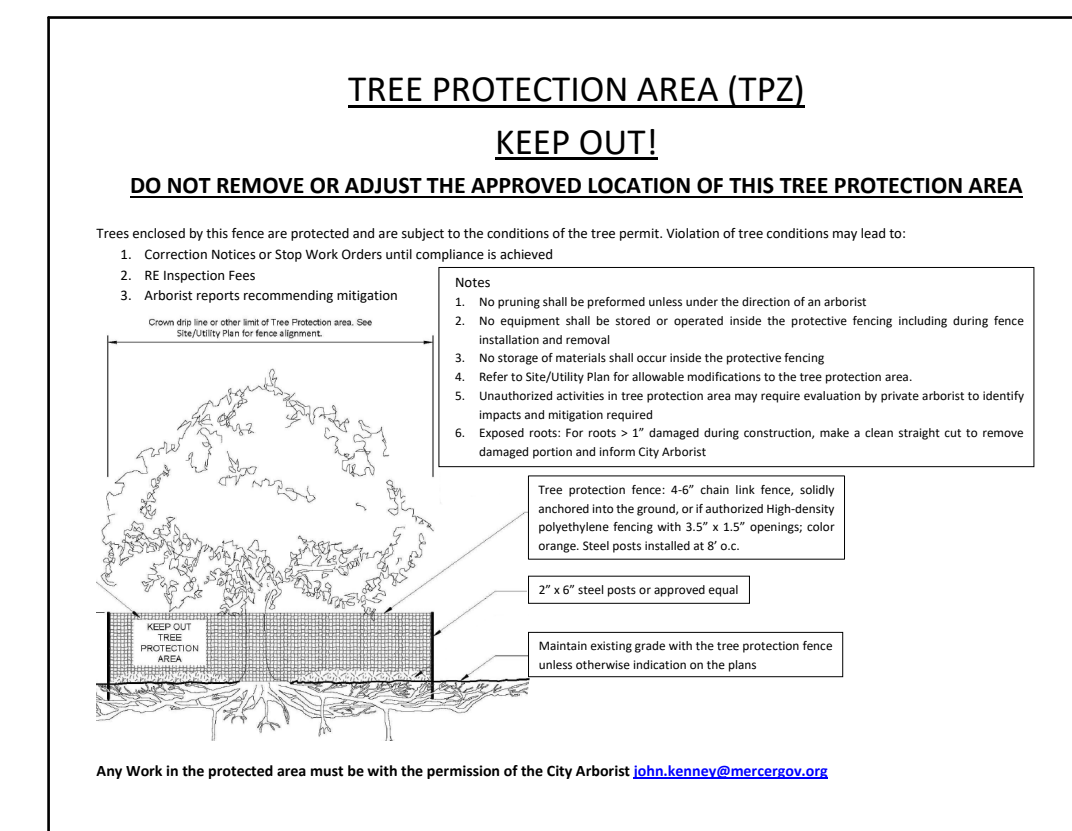
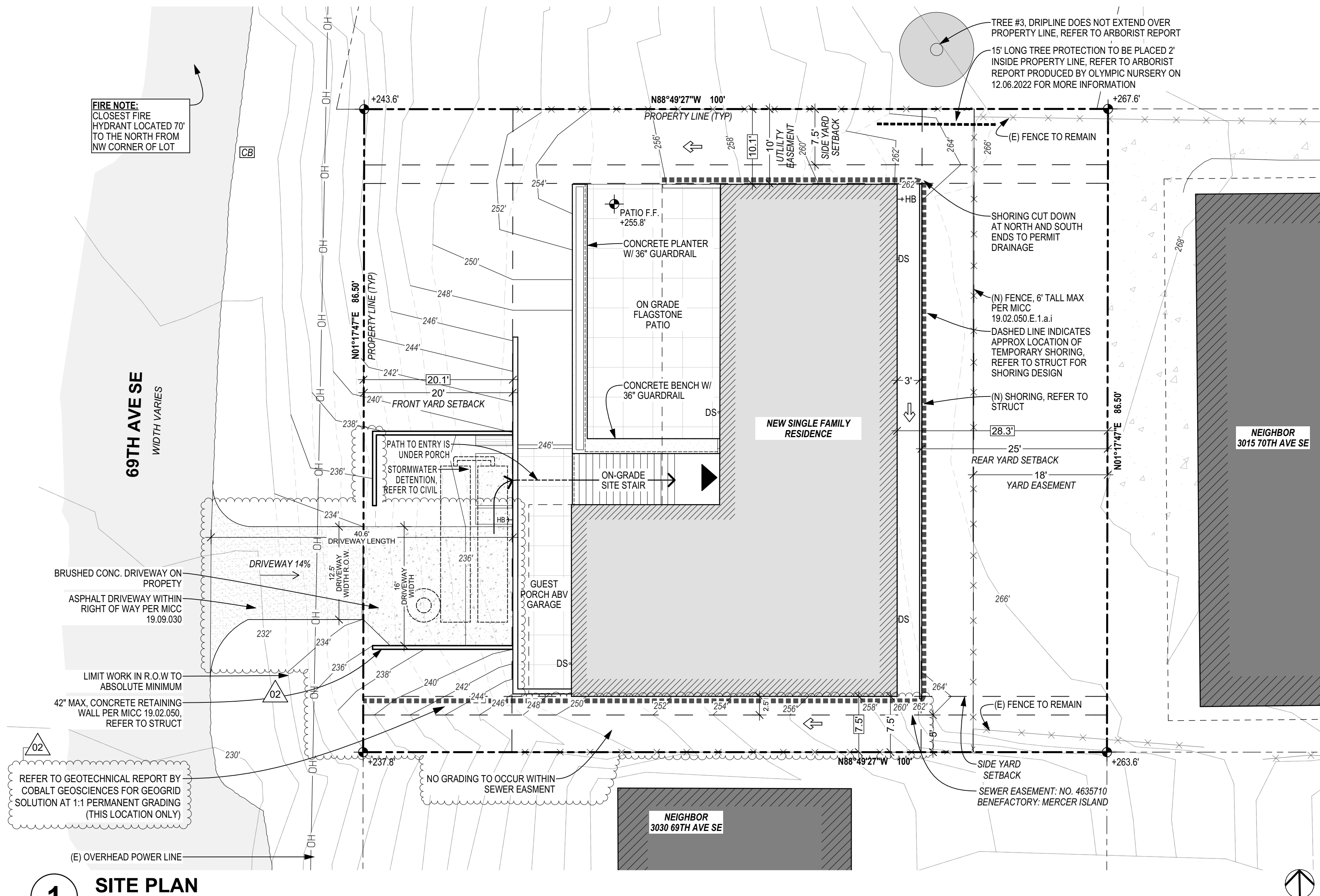

SITE PLAN NOTES:

A. RE-SURVEY FOR ADDITIONAL EXISTING SITE INFORMATION. ALL ELEVATIONS ARE BASED ON SURVEY DATED MAY 21, 2021 BY D.R. STRONG CONSULTING ENGINEERS.

B. ALL DIMENSIONS ARE TO FACE OF CONC / FINISH, U.N.O.

C. ALL DIMENSIONS TO PROPERTY/SETBACK LINES ARE MEASURED AT ANGLES PERPENDICULAR TO PROPERTY/SETBACK LINES.

D. **PER MICC 19.02.020(F)(3)(d)**, DEVELOPMENT PROPOSALS FOR A NEW SINGLE-FAMILY HOME SHALL REMOVE JAPANESE KNOTWEED (*POLYGONUM CURPADIUM*) AND REGULATED CLASS A, B, AND REGULATED CLASS C WEEDS IDENTIFIED ON THE KING COUNTY NOXIOUS WEED LIST, AS AMENDED, FROM REQUIRED LANDSCAPING AREAS ESTABLISHED PURSUANT TO SUBSECTION (F)(3)(A) OF THIS SECTION. NEW LANDSCAPING ASSOCIATED WITH NEW SINGLE-FAMILY HOME SHALL NOT INCORPORATE ANY WEEDS IDENTIFIED ON THE KING COUNTY NOXIOUS WEED LIST, AS AMENDED. PROVIDED, THAT REMOVAL SHALL NOT BE REQUIRED IF THE REMOVAL WILL RESULT IN INCREASED SLOPE INSTABILITY OR RISK OF LANDSLIDE OR EROSION.

E. SEWER LINE WAS LOCATED ON 2023.04.04 BY ADVANCED UNDERGROUND UTILITY LOCATING. LOCATION AND DEPTH OF LINE WAS FOUND USING GROUND PENETRATING RADAR AND SONDE LOCATING. VIDEO OF LINE ALONGSIDE MERCER ISLAND SIDE SEWER VIDEO INSPECTION REPORT HAS BEEN SUBMITTED AS PART OF THIS PERMIT SUBMITTAL

TREE PROTECTION FENCING DETAIL

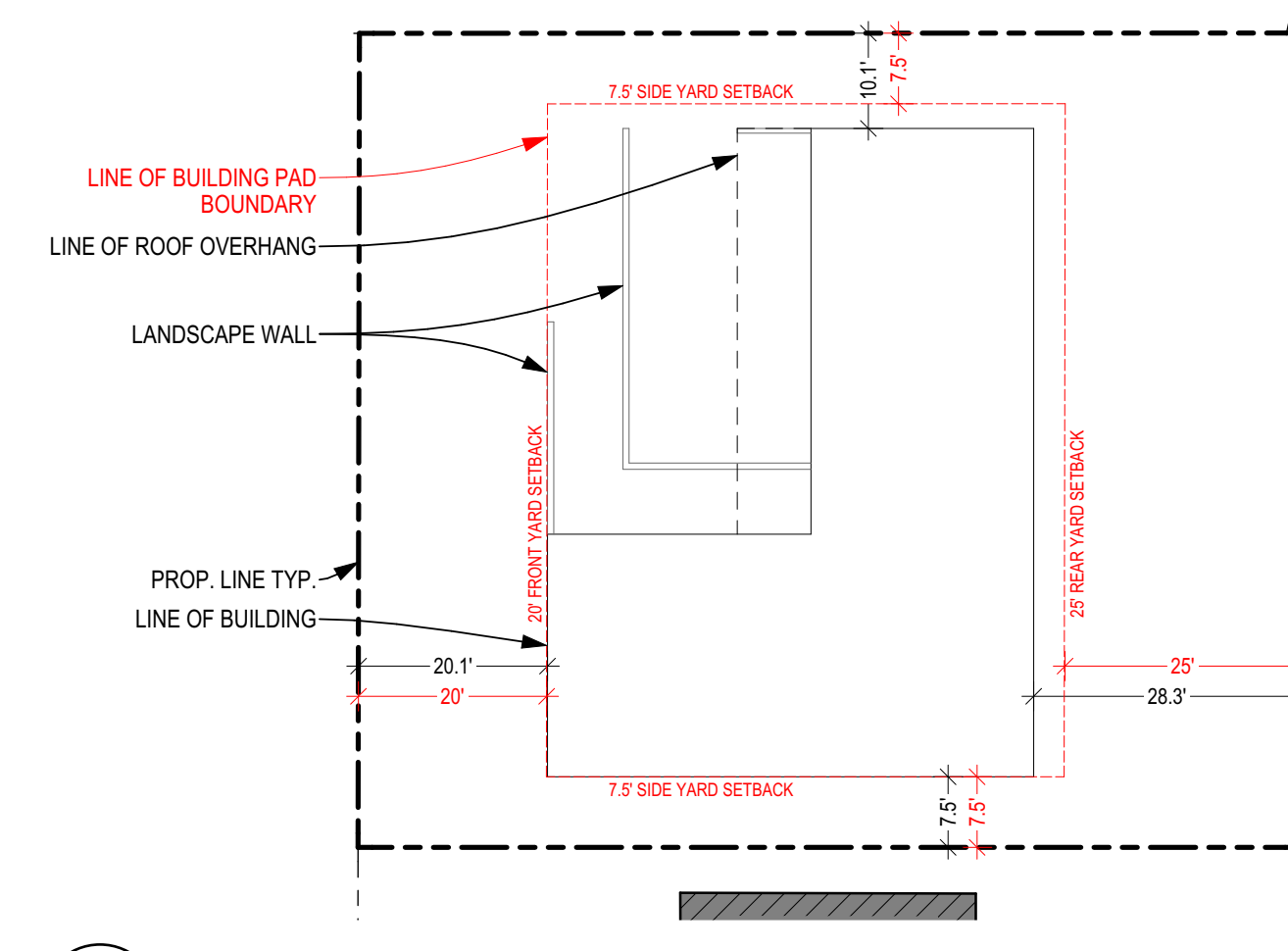

LANDSCAPE PLAN LEGEND:

- ▲ PRIMARY ENTRANCE
- ↔ NATURAL DRAINAGE FLOW DIRECTION
- ELEV. SPOT ELEVATION
- (E) TOPO CONTOUR TO REMAIN
- NEW TOPO CONTOUR
- - - RESHAPED (E) TOPO CONTOUR
- - - PROPERTY LINE
- - - PROPERTY SETBACK LINE
- OH — POWER LINE (OVERHEAD)
- S — SEWER LINE
- SW — STORMWATER PIPE
- W — WATER LINE
- CB — STORMWATER CATCH BASIN
- ⊙ — EXISTING OVERHEAD POWER POLE
- NEW STRUCTURE FOOTPRINT
- ▨ NEW OUTDOOR PATIO FOOTPRINT
- NEIGHBORING STRUCTURES
- CONCRETE (SLAB-ON GRADE)

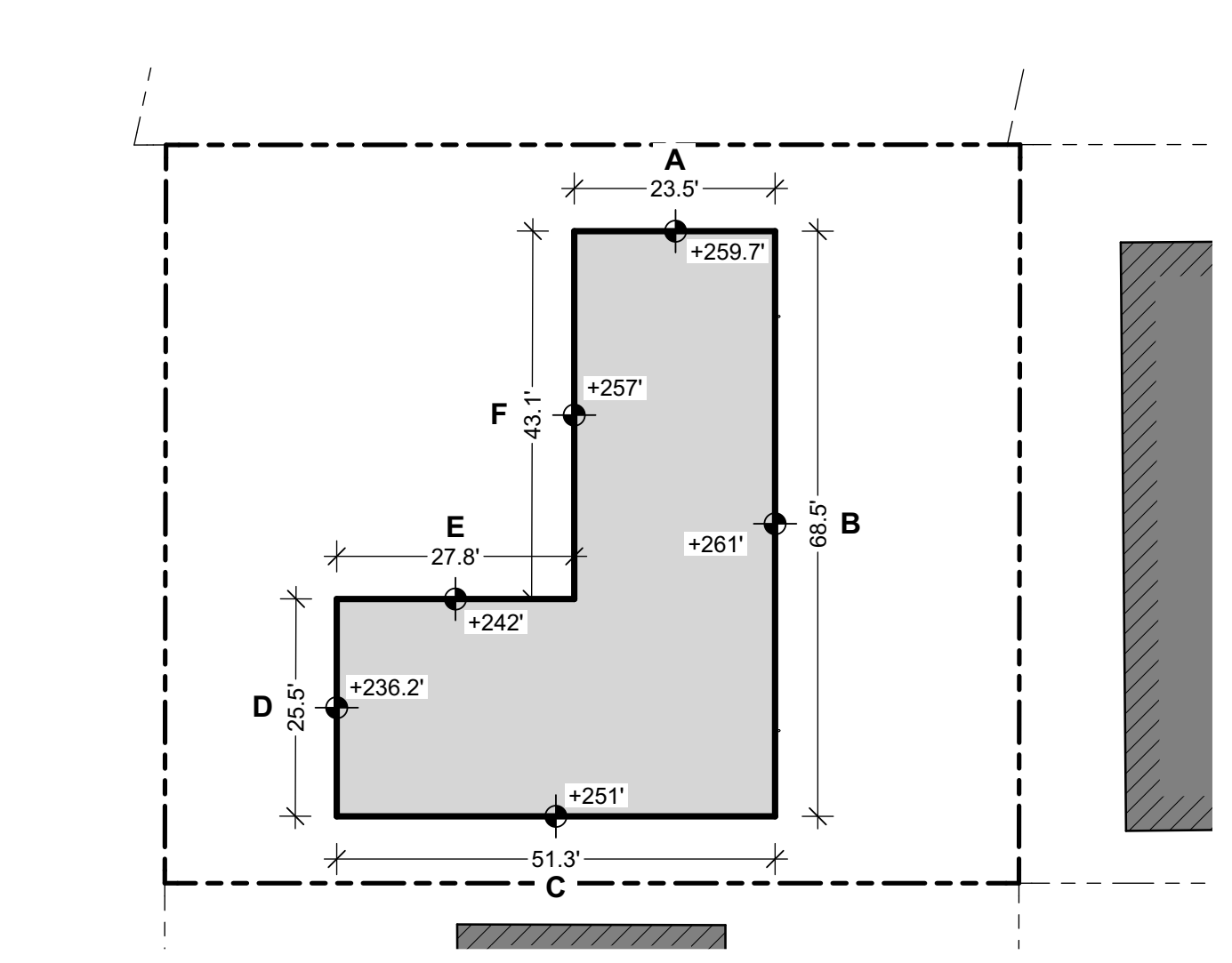
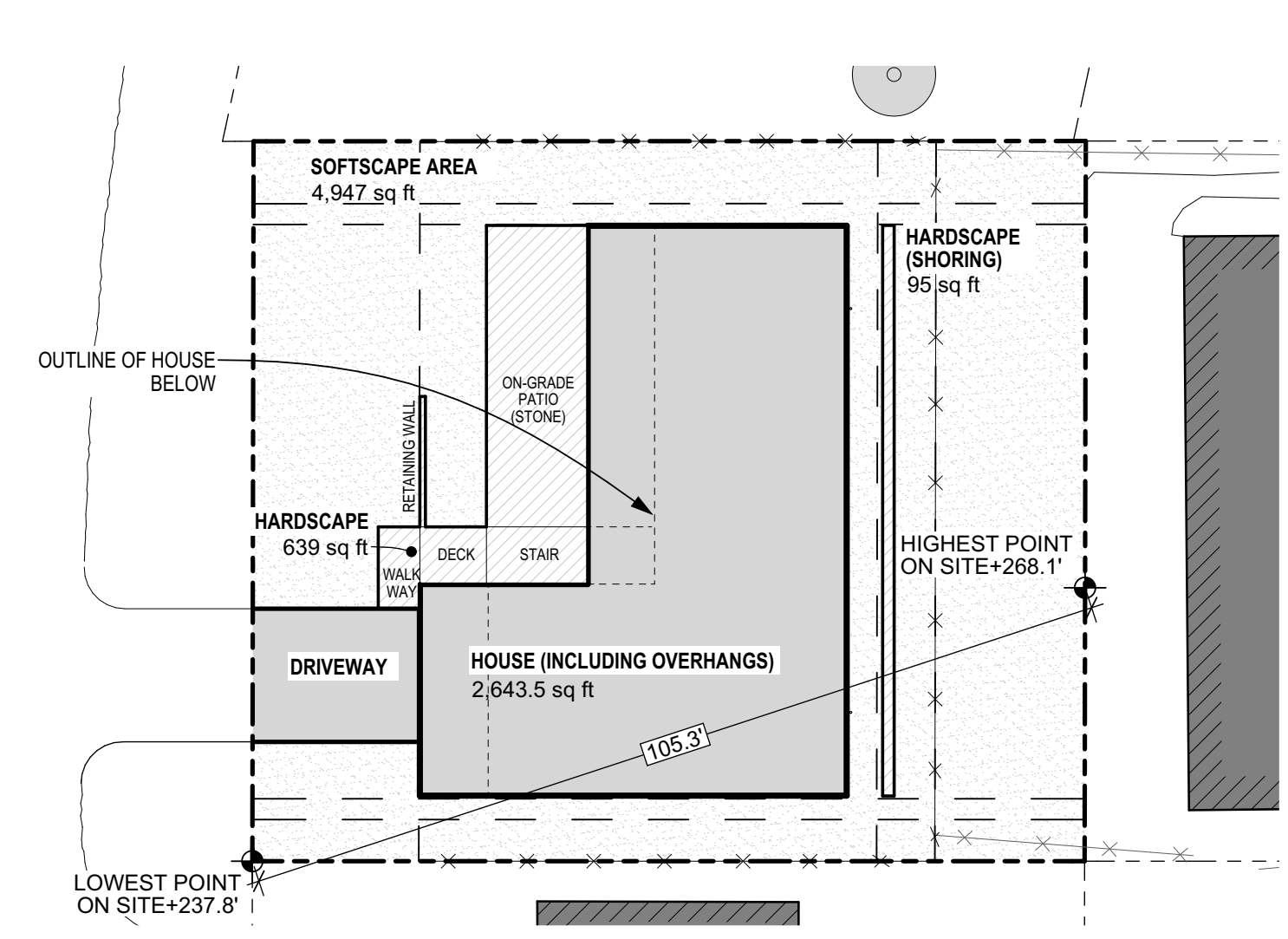
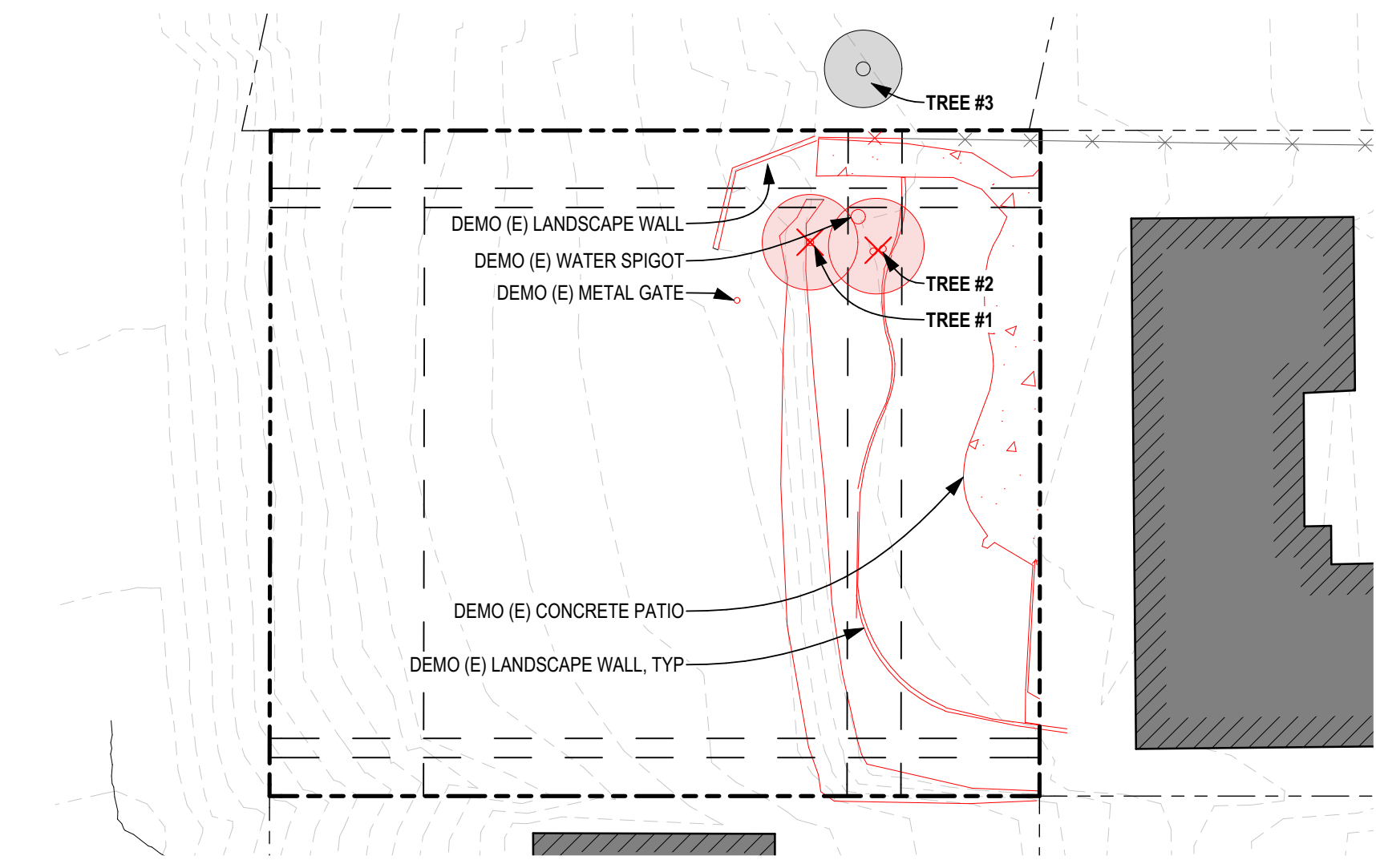

TREE #	SPECIES	DBH	DRIP	CNDTN	CNDTN	CNDTN	RMV	RTN
1	COTONEASTER DAMERII	8.5"	6"	FAIR	SHRUB GROWN AND PRUNED TO HAVE TREE-LIKE FORM. TWO 6" STEMS AT 38"	NOT SIGNIFICANT	YES	
2	FIG, FRUITING	3.7"	4"	GOOD	FIVE STEM, 1.0, 1.5, 1.5, 2.0, 2.0 SQ ROOT OF SUM OF EACH STEM SQUARED	NOT SIGNIFICANT	YES	
3	ACER RUBRUM, RED MAPLE	EST 20"	8"	GOOD	OFF-SITE, TO BE PROTECTED AT DRIPLINE	OFF-SITE		YES

KEY:

- LOT COVERAGE (ROOF/OVERHANGS AND DRIVEWAY)
- ▨ HARDSCAPE
- SOFTSCAPE

REQUIRED LANDSCAPE AREA:
>LOT AREA = 8,652
>PER MICC 19.02.020 F.3.a REQUIRED LANDSCAPING AREA FOR SITE WITH 29.4% SLOPE IS 65%
>REQUIRED LANDSCAPE AREA = 8,652 X 0.65 = 5,623.8 SQFT
>4,929.5 SQFT SOFTSCAPE + 749 SQFT HARDSCAPE = 5,678.5 SQFT LANDSCAPE
TOTAL = 5,678.5 SQFT PROPOSED > 5,623.8 SQFT REQ'D



CONTACT
SHED ARCHITECTURE & DESIGN
1401 S JACKSON ST
SEATTLE, WA 98144
206.320.8700

PROJECT
SULLIVAN
3024 69th Ave SE
MERCER ISLAND, WA 98040

ISSUE	DATE
PRE APP #1 (PRE22-0433)	2022.08.16
CAR 2 (CAO22-023)	2022.12.08
PERMIT SET	2023.01.20
REVISION #1	2023.05.26
REVISION #2	2023.07.07

DRAWING TITLE
SITE PLAN & DIAGRAMS

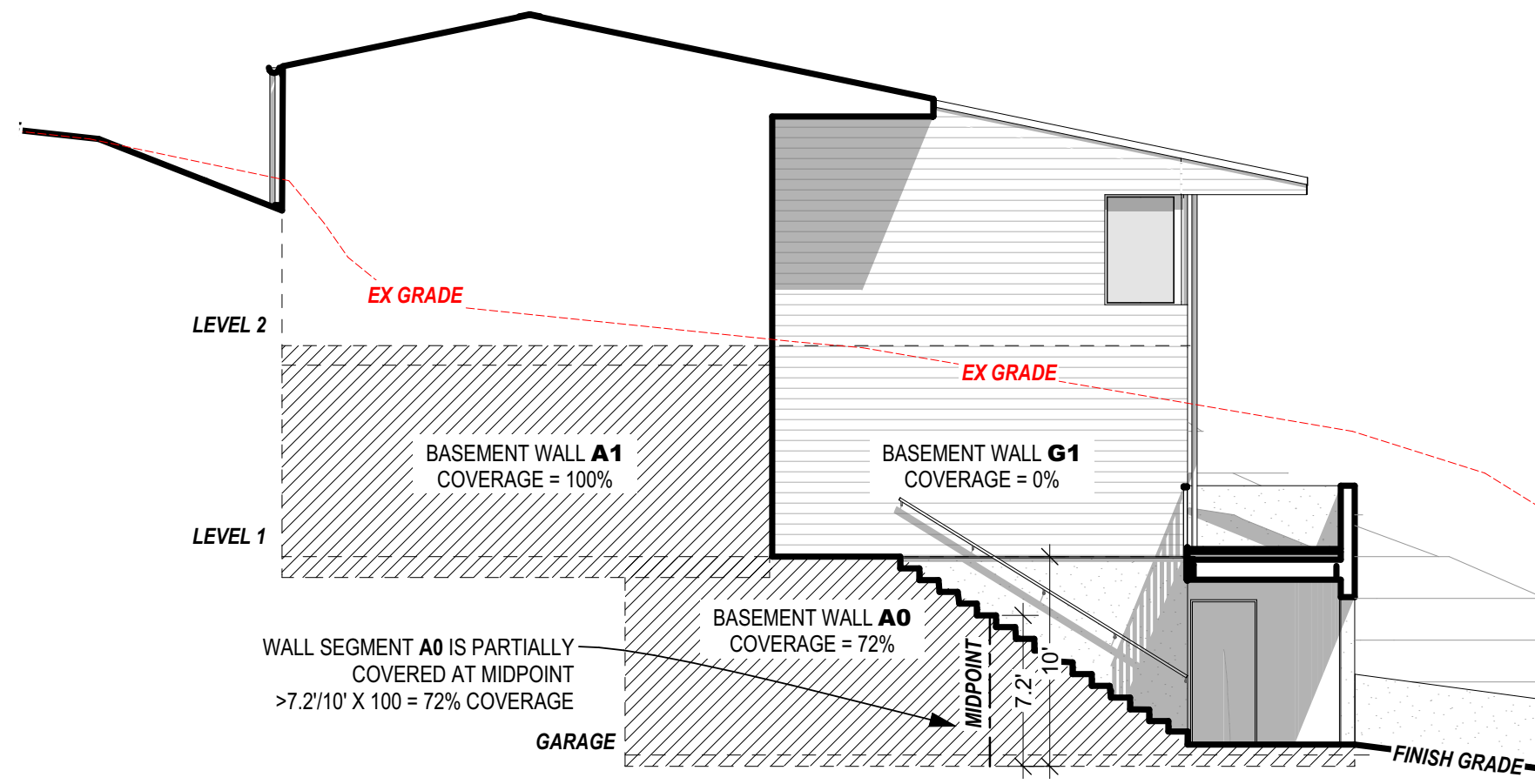

1 NORTH ELEVATION
SCALE: 1/8" = 1'-0"

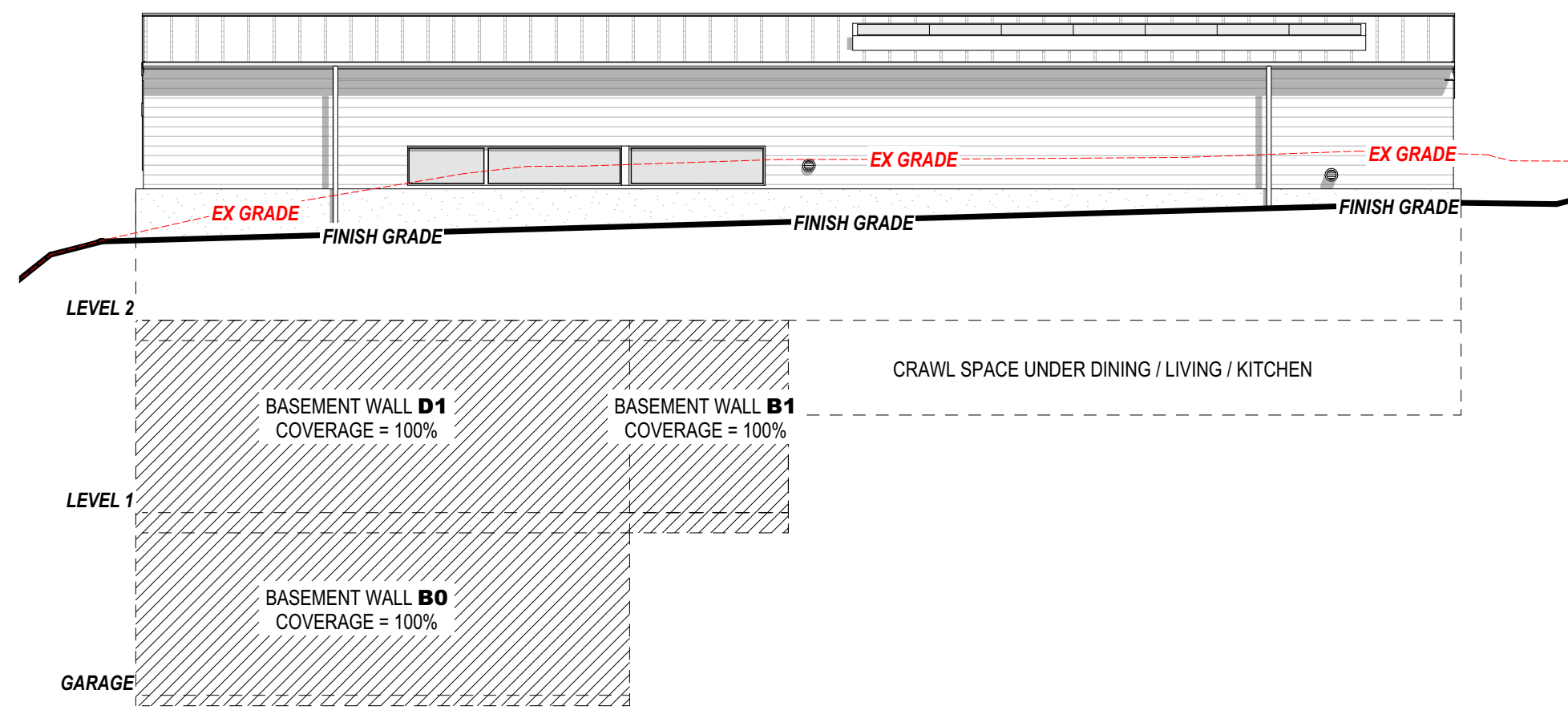

2 EAST ELEVATION
SCALE: 1/8" = 1'-0"

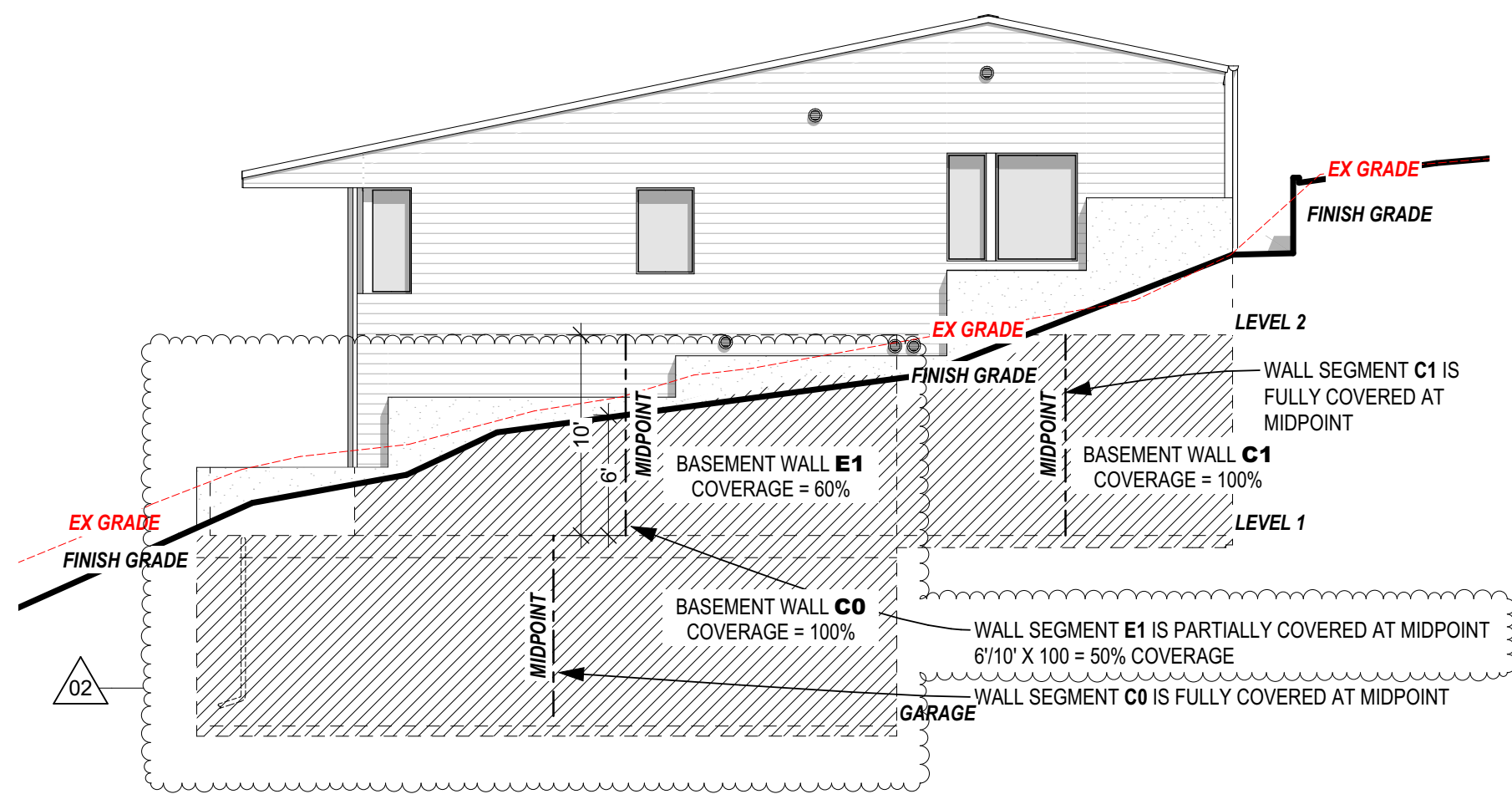

3 SOUTH ELEVATION
SCALE: 1/8" = 1'-0"

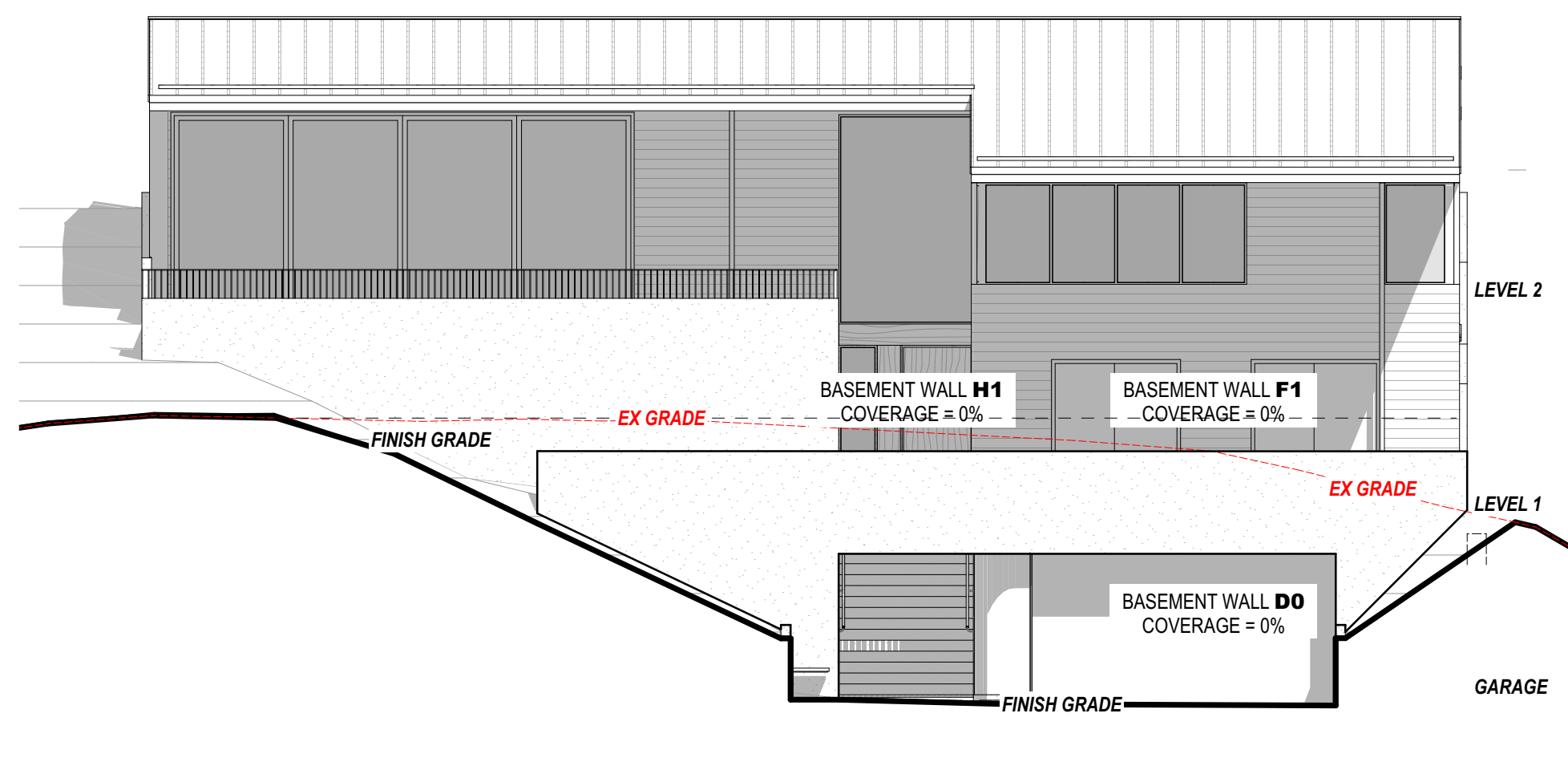

4 WEST ELEVATION
SCALE: 1/8" = 1'-0"

GARAGE: 232.3 SQFT

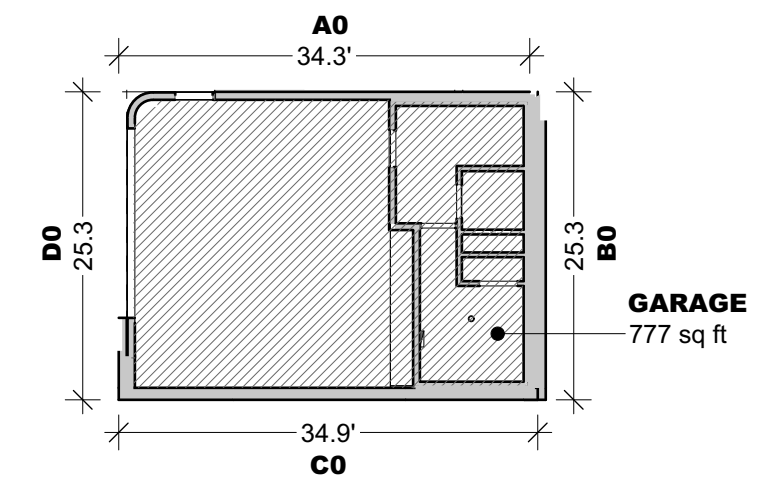

WALL SEGMENT	LENGTH X	COVERAGE	RESULT
A0	34.9	72%	25.1%
B0	25.3	100%	25.3%
C0	34.9	100%	34.9%
D0	25.3	0%	0%
TOTALS	120.4'	NA	85.3%

BASEMENT FLOOR CALCULATION
 >PORTION OF EXCLUDED BSMT FLR AREA = TOTAL BSMT FLR AREA X (SUM OF WALL SEGMENT COVERAGE X WALL SEGMENT LENGTH) / TOTAL OF ALL WALL SEGMENT LENGTHS
 >EXCLUDED AREA
 = 777 SQFT X (WALL A0: 34.9' X 72% + WALL B0: 25.3' X 100% + WALL C0: 34.9' X 100% + WALL D0: 25.3' X 0%) / 120.4'
 = 777 SQFT X (85.3%/120.4')
 = 777 SQFT X 70.1%
 = 544.7 SQFT
 777 SQFT - 544.7 SQFT = TOTAL BSMT AREA
TOTAL BSMT AREA = 232.3 SQFT

LEVEL 1: 408.5 SQFT

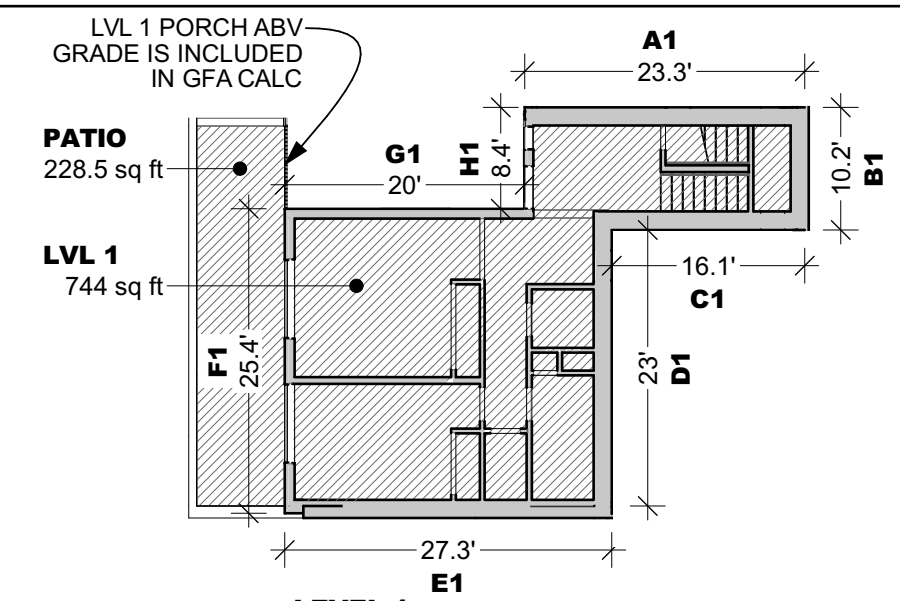

LEVEL 1 TOTAL: 895 SQFT

WALL SEGMENT	LENGTH X	COVERAGE	RESULT
A1	23.3	100%	23.3%
B1	10.2	100%	10.2%
C1	16.1	100%	16.1%
D1	23.3	23%	23%
E1	27.3	60%	16.4%
F1	25.4	0%	0%
G1	20	0%	0%
H1	8.4	0%	0%
TOTALS	153.7'	NA	89.0%

BASEMENT FLOOR CALCULATION
 >PORTION OF EXCLUDED BSMT FLR AREA = TOTAL BSMT FLR AREA X (SUM OF WALL SEGMENT COVERAGE X WALL SEGMENT LENGTH) / TOTAL OF ALL WALL SEGMENT LENGTHS
 >EXCLUDED AREA
 = 972.5 SQFT X (WALL A1: 23.3' X 100% + WALL B1: 10.2' X 100% + WALL C1: 16.1' X 100% + WALL D1: 23.3' X 100% + WALL E1: 27.3' X 55% + WALL F1: 25.4' X 0% + WALL G1: 20' X 0% + WALL H1: 8.4' X 0%) / 153.7'
 = 972.5 SQFT X (89.0% / 153.7')
 = 972.5 SQFT X 58%
 = 564 SQFT
 972.5 SQFT - 564 SQFT = TOTAL BSMT AREA
TOTAL BSMT AREA = 408.5 SQFT

LEVEL 2: 2,307.8 SQFT

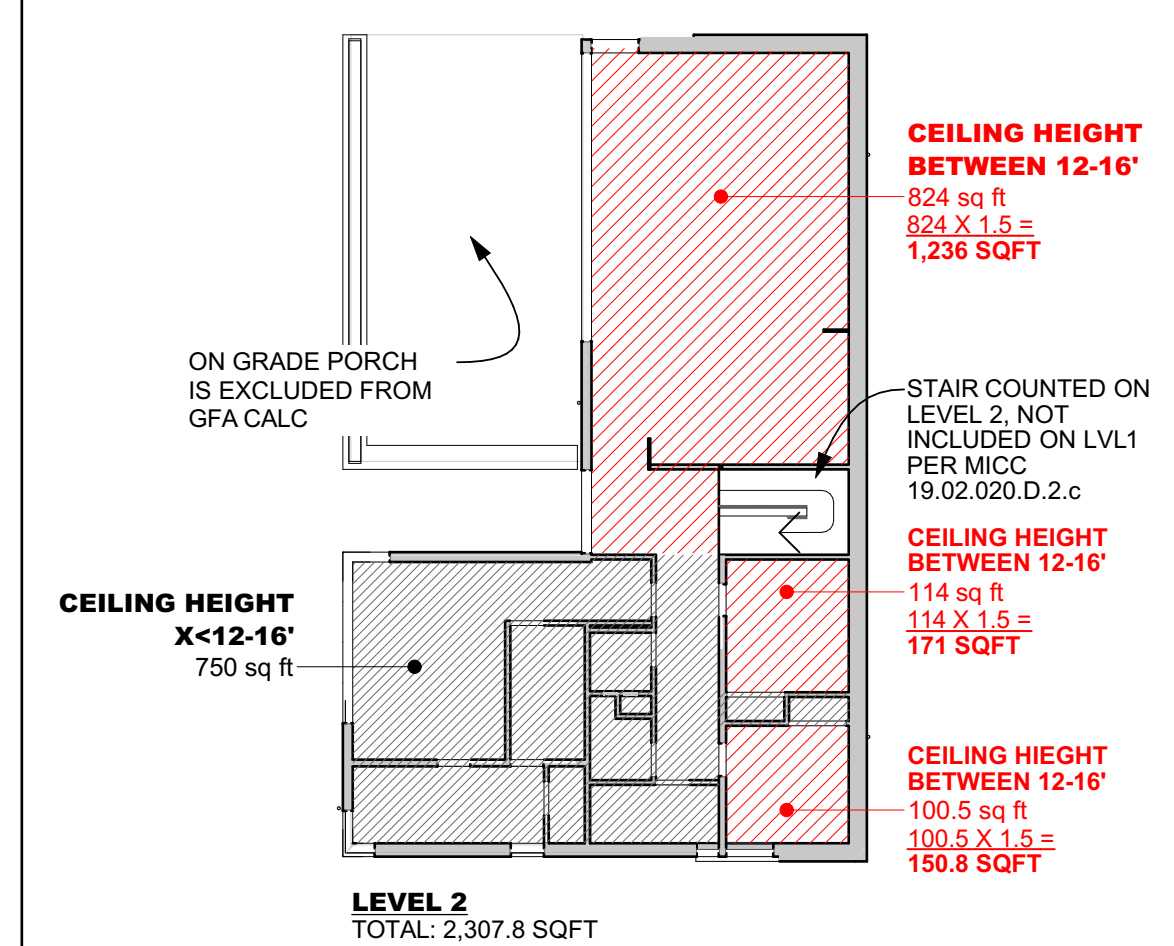

TOTAL: 2,958.3 SQFT

GROSS FLOOR AREA:
 ALLOWED:
 LOT AREA: 8,650 SQFT
 GFA PER MICC 19.02.020.D.1: 40%
 ALLOWED: 8,650*0.40 = 3,460 SQFT
 PROPOSED:
 LEVEL 0: 232.3 SQFT
 LEVEL 1: 408.5 SQFT
 LEVEL 2: 2,307.8 SQFT
TOTAL GFA: 2,958.3 SQFT (34.2%) PROPOSED < 3,460 SQFT (40%) ALLOWED

NOTE:
 >PER EMAIL WITH ANDREW LEON @ MERCER ISLAND
 GROSS FLOOR AREA IS A LAND USE METRIC AND DOES NOT TAKE IRC DEFINITIONS INTO ACCOUNT. AS A RESULT, THE BASEMENT EXCLUSION PROVISION SET FORTH IN TITLE 19 MICC, APPENDIX B CAN BE APPLIED TO THE BOTTOM TWO FLOORS OF THE PROPOSED HOUSE

5 GFA + BASEMENT CALCULATION
SCALE: 1" = 20'



CONTACT
 SHED ARCHITECTURE & DESIGN
 1401 S JACKSON ST
 SEATTLE, WA 98144
 206.320.8700

PROJECT
SULLIVAN
 3024 69th Ave SE
 MERCER ISLAND, WA 98040

ISSUE	DATE
PRE APP #1 (PRE22-0433)	2022.08.16
CAR 2 (CAO22-023)	2022.12.08
PERMIT SET	2023.01.20
REVISION #1	2023.05.26
REVISION #2	2023.07.07

DRAWING TITLE
GFA+BASEMENT CALC

LANDSCAPE PLAN NOTES:

A. PER MICC 19.02.020(F)(3)(d): DEVELOPMENT PROPOSALS FOR A NEW SINGLE-FAMILY HOME SHALL REMOVE JAPANESE KNOTWEED (POLYGONUM CUSPIDATUM) AND REGULATED CLASS A, REGULATED CLASS B, AND REGULATED CLASS C WEEDS IDENTIFIED ON THE KING COUNTY NOXIOUS WEED LIST, AS AMENDED, FROM REQUIRED LANDSCAPING AREAS ESTABLISHED PURSUANT TO SUBSECTION (F)(3)(A) OF THIS SECTION. NEW LANDSCAPING ASSOCIATED WITH NEW SINGLE-FAMILY HOME SHALL NOT INCORPORATE ANY WEEDS IDENTIFIED ON THE KING COUNTY NOXIOUS WEED LIST, AS AMENDED. PROVIDED, THAT REMOVAL SHALL NOT BE REQUIRED IF THE REMOVAL WILL RESULT IN INCREASED SLOPE INSTABILITY OR RISK OF LANDSLIDE OR EROSION.

B. REFER TO A-001 FOR LANDSCAPE / HARDSCAPE CALCULATIONS

C. REFER TO A-001 FOR EXISTING TREE AND VEGETATION REMOVAL / DEMO PLAN

D. ALL PLANTS ARE NATIVE AND SELECTED FROM THE KING COUNTY NATIVE PLANT LIST. PLANTS LOCATED ON STEEP SLOPE WERE SELECTED FROM "SLOPE STABILIZATION AND EROSION CONTROL USING VEGETATION" PRODUCED BY THE WASHINGTON STATE DEPARTMENT OF ECOLOGY

E. PER GEOTECHNICAL REPORT PRODUCED BY COBALT GEOSCIENCES: FOR SLOPES 3H:1V OR FLATTER, TYPICAL LANDSCAPE PLANTINGS WITH MULCH/COMPOST AND BARK SURFACING IS SUITABLE. FOR SLOPES STEEPER THAN 3H:1V, MULCH AND COMPOST SHOULD BE PLACED, THEN COVERED WITH JUTE UNTIL PLANTINGS ARE WELL ESTABLISHED

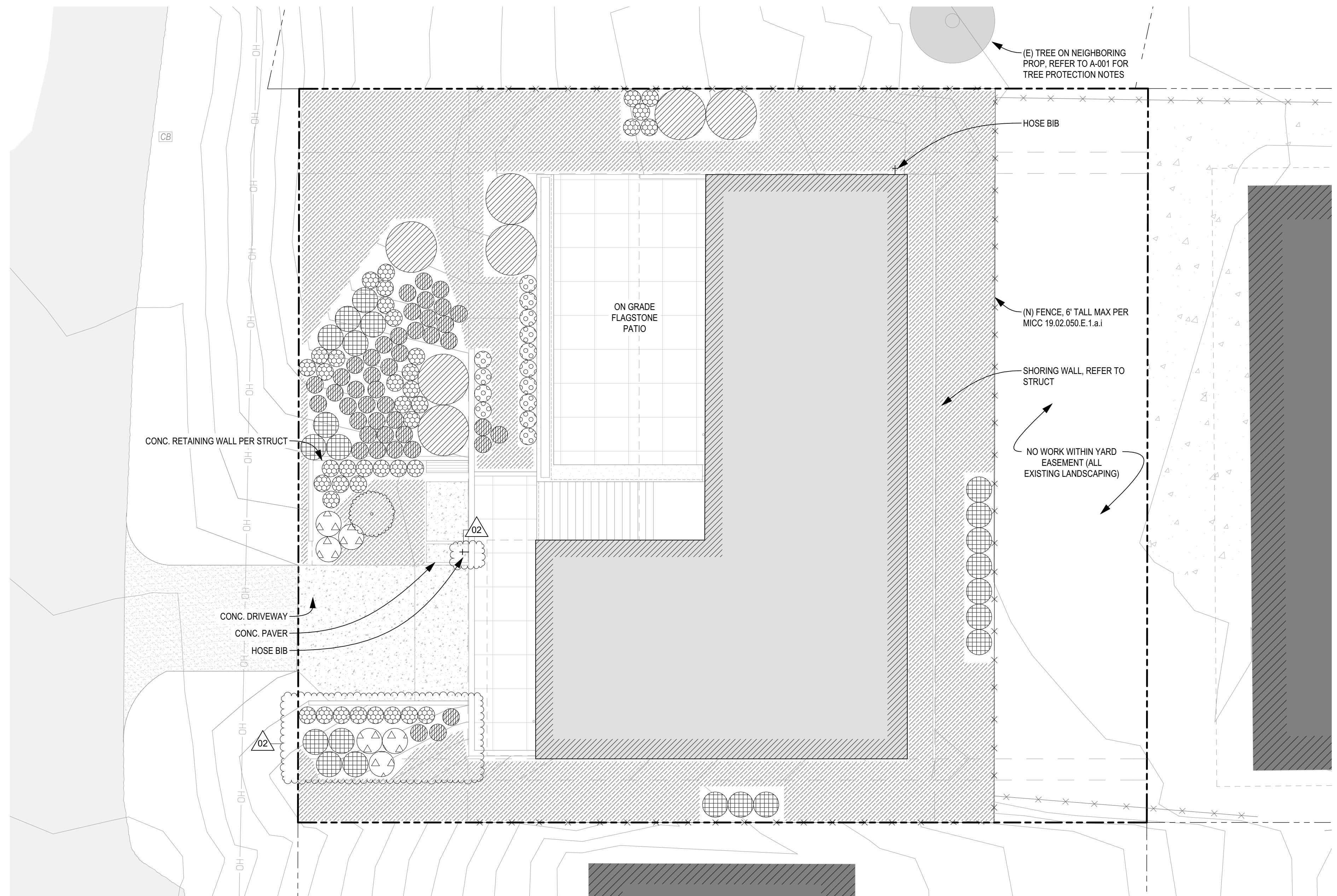

1 LANDSCAPE PLAN
SCALE: 1/8" = 1'-0"

PLANT SCHEDULE:					
TREE SCHEDULE:					
SYMBOL	QUANTITY	BOTANICAL NAME	COMMON NAME	SIZE	SPACING
	1	CORNUS NUTTALLII	PACIFIC DOGWOOD	1.5" CAL.; 6+ HT MIN	AS SHOWN
SHRUB SCHEDULE:					
SYMBOL	QUANTITY	BOTANICAL NAME	COMMON NAME	SIZE	SPACING
	7	PHILADELPHUS LEWISII	MOCK ORANGE	3 GAL.	72"
	22	VACCINIUM OVATUM	EVERGREEN HUCKLEBERRY	1 GAL.	36"
	6	ROSA NUTKANA	NOOTKA ROSE	1 GAL.	36"
	43	SYMPHORICARPOS ALBUS	SNOWBERRY	1 GAL.	24"
	42	ARCTOSAPHYLOS UVA-URSI	BEARBERRY	1 GAL.	24"
	14	LONICERA CILIOSA	ORANGE HONEYCUCKLE	1 GAL.	24"
GROUNDCOVER SCHEDULE:					
SYMBOL	QUANTITY	BOTANICAL NAME	COMMON NAME	SIZE	SPACING
	N/A	N/A	NATIVE PLANT SEED MIXES (ANNUAL AND PERENNIAL GRASS AND FORB MIXES)		APPLY AS RECOMMENDED



CONTACT
SHED ARCHITECTURE & DESIGN
1401 S JACKSON ST
SEATTLE, WA 98144
206.320.8700

PROJECT
SULLIVAN
3024 69th Ave SE
MERCER ISLAND, WA 98040

ISSUE	DATE
PRE APP #1 (PRE22-0433)	2022.08.16
CAR 2 (CAO22-023)	2022.12.08
PERMIT SET	2023.01.20
REVISION #1	2023.05.26
REVISION #2	2023.07.07

DRAWING TITLE
LANDSCAPE PLAN

A-003

FOUNDATION PLAN NOTES:	
A.	ALL ELEVATIONS RELATIVE TO FUTURE LEVEL 01 SUBFLOOR: 0' (246' ABV SEA LEVEL).
B.	ALL DIMS ARE TO F.O. CONC. U.N.O.
C.	ALL INDICATED ALIGNMENTS ARE TO F.O. FINISH, U.N.O.
D.	RE: STRUCTURAL FOR ADDITIONAL INFO.
E.	COORD. ALL CONC. SLAB CONTROL JOINTS W/ ARCH.
F.	AXONOMETRIC DRAWINGS SHOW ONLY FOUNDATION WALLS & FOOTINGS; RE: PLANS FOR SLAB ON GRADE LOCATIONS, RE: STRUCT. FOR SOLDIER PILE AND SHORING LOCATIONS
G.	TO PROTECT (E) SEWER LINE IN SEWER EASEMENT, SHORING TO BE INSTALLED IN ALTERNATING METHOD OR EACH PILE IS TO BE PLACED AND BACKFILLED WITH CONCRETE/LEAN MIX IMMEDIATELY, PER GEOTECHNICAL REPORT PRODUCED BY COBALT GEOSCIENCES

FOUNDATION PLAN LEGEND:	
	ELEVATION CHANGE/STEP
	TOP OF CONC. SLAB (TOS) TOP OF WALL (TOW) TOP OF FOOTING (TOF)
	FINISHED GRADE ELEVATION
	CONCRETE (SLAB-ON GRADE)

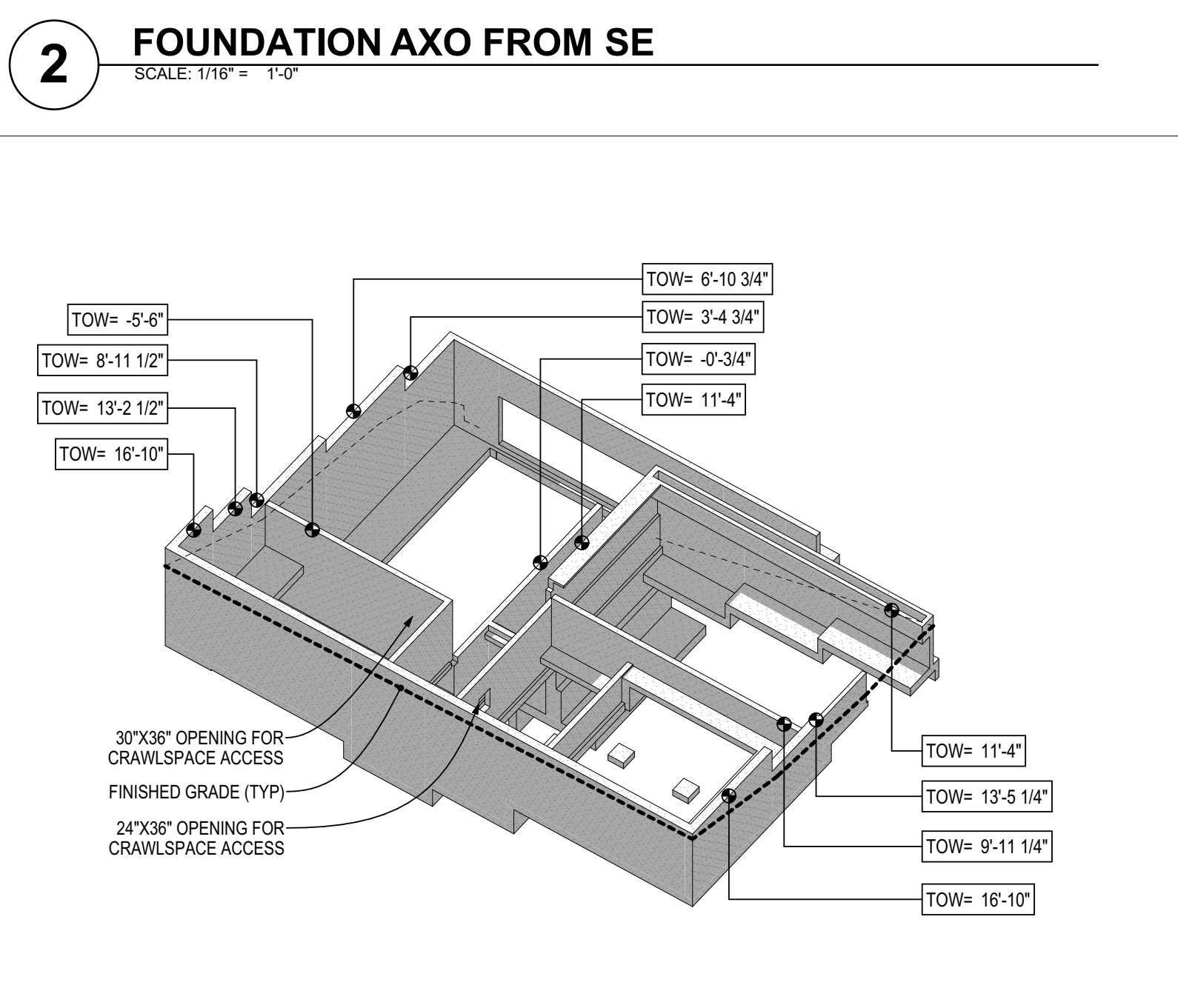
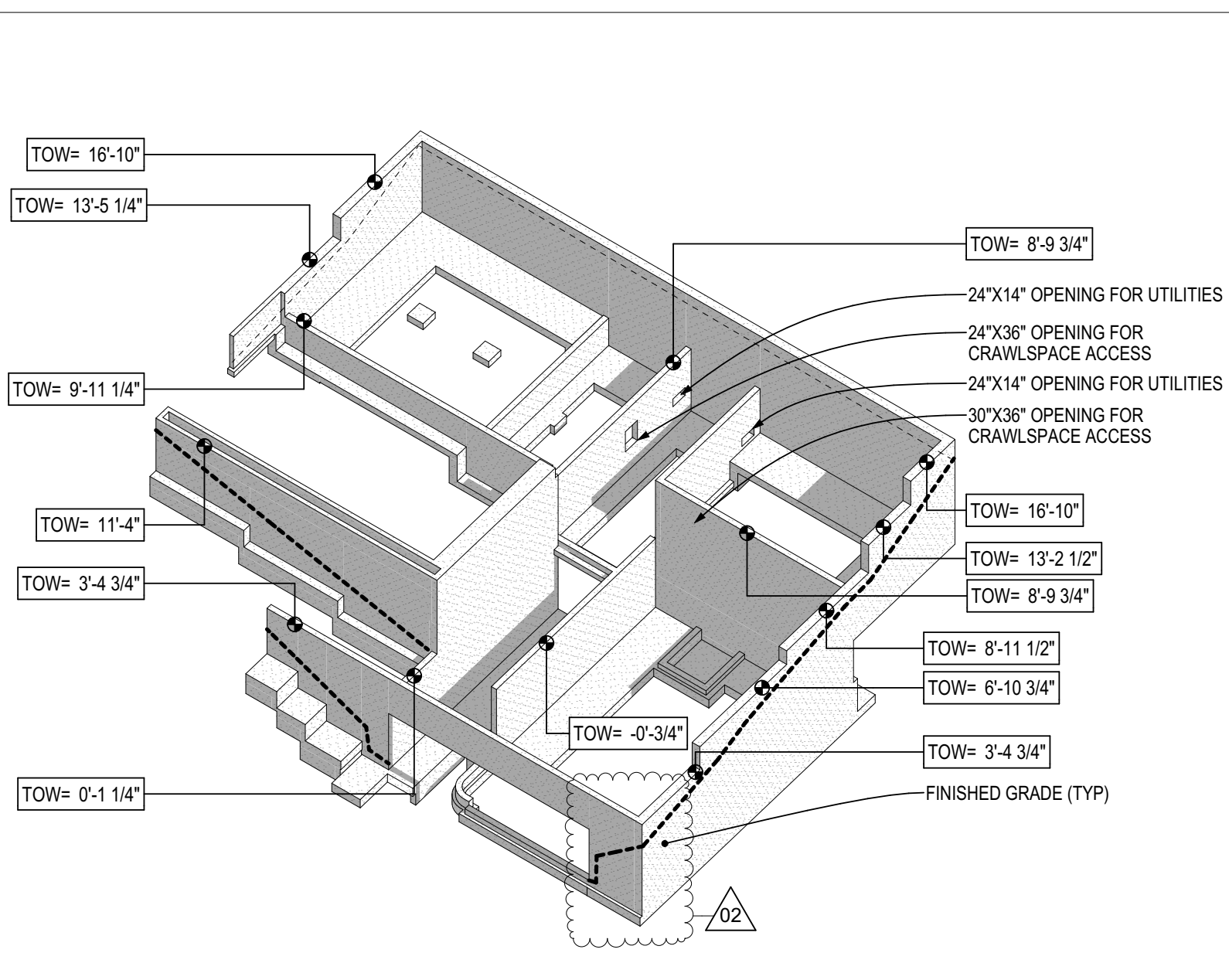
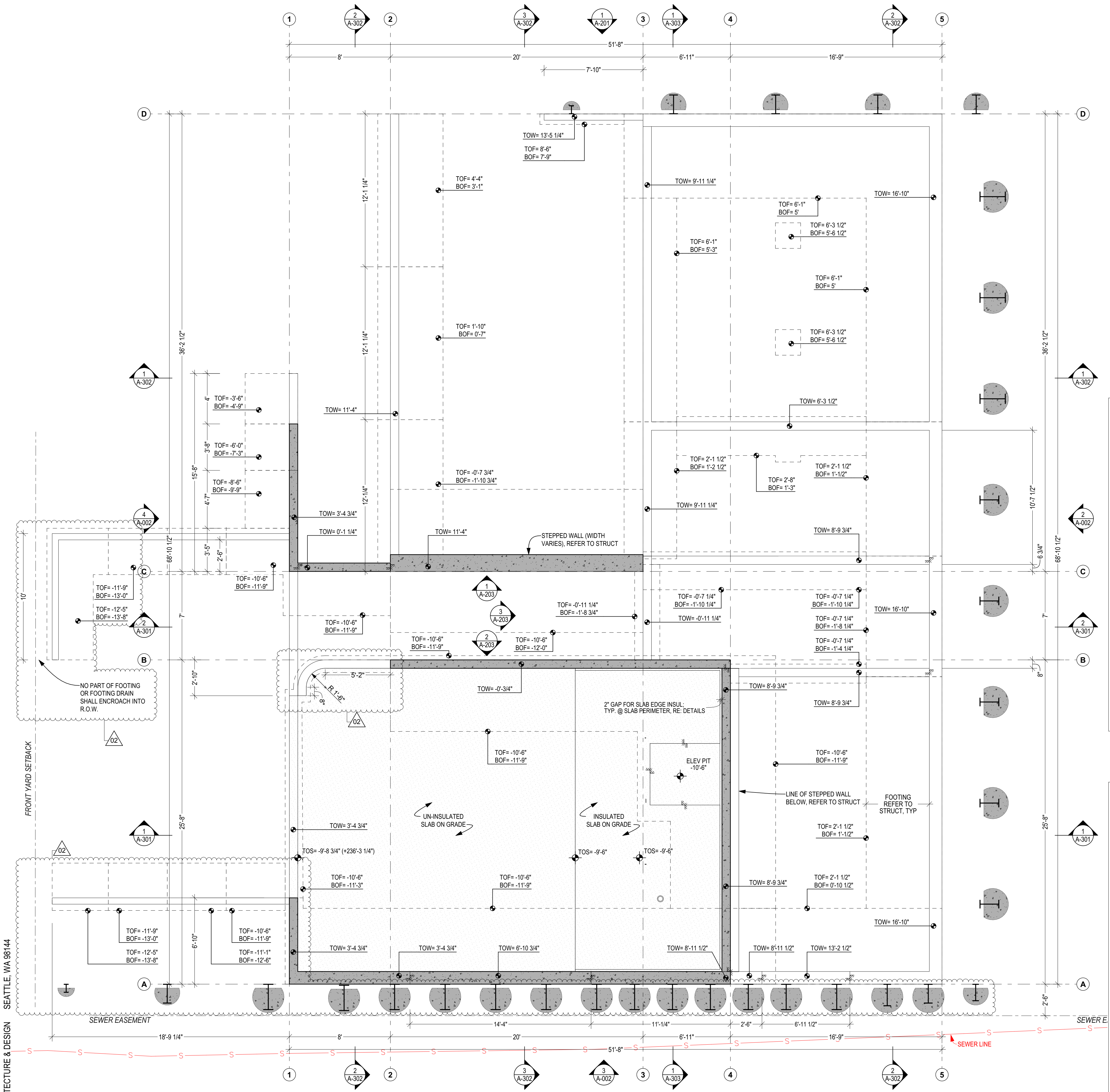

1 FOUNDATION FLOOR PLAN
SCALE: 1/4" = 1'-0"

2 FOUNDATION AXO FROM SE
SCALE: 1/16" = 1'-0"

3 FOUNDATION AXO FROM NW
SCALE: 1/16" = 1'-0"

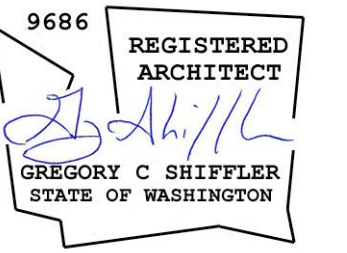

CONTACT
 SHED ARCHITECTURE & DESIGN
 1401 S JACKSON ST
 SEATTLE, WA 98144
 206.320.8700

PROJECT
SULLIVAN
 3024 69th Ave SE
 MERCER ISLAND, WA 98040

ISSUE	DATE
PRE APP #1 (PRE22-0433)	2022.08.16
CAR 2 (CAO22-023)	2022.12.08
PERMIT SET	2023.01.20
REVISION #1	2023.05.26
REVISION #2	2023.07.07

DRAWING TITLE
FOUNDATION FLOOR PLAN

PLAN NOTES:

- ALL DIMS ARE TO F.O. FRAMING OR F.O. CONC. U.N.O.
- ALL INDICATED ALIGNMENTS ARE TO F.O. FINISH, U.N.O.
- WINDOW OPENING DIMENSIONS ARE MEASURED FROM THE ROUGH OPENING U.N.O. -- RE: SCHEDULES & ELEVATIONS FOR ADDITIONAL INFO.
- RE: STRUCTURAL FOR FRAMING INFO.
- ALL FLOOR TRANSITIONS SHALL BE AT CENTER OF DOOR LEAF, U.N.O.
- ALL INTERIOR PARTITIONS ARE P2 U.N.O.

SYMBOL LEGEND:

- ◀ MAIN ENTRY DOOR
- ⊙ COMBINATION SMOKE & CARBON MONOXIDE ALARM
- ⊙ 50 CFM (U.N.O.) EXHAUST FAN
- ⊙→ INDICATES SIDE OF SHEAR WALL TO RECEIVE SHEATHING (RE: STRUCT FOR MORE INFO)
- ⊥ ASSEMBLY TAG, REFER TO A-601 FOR MORE INFO

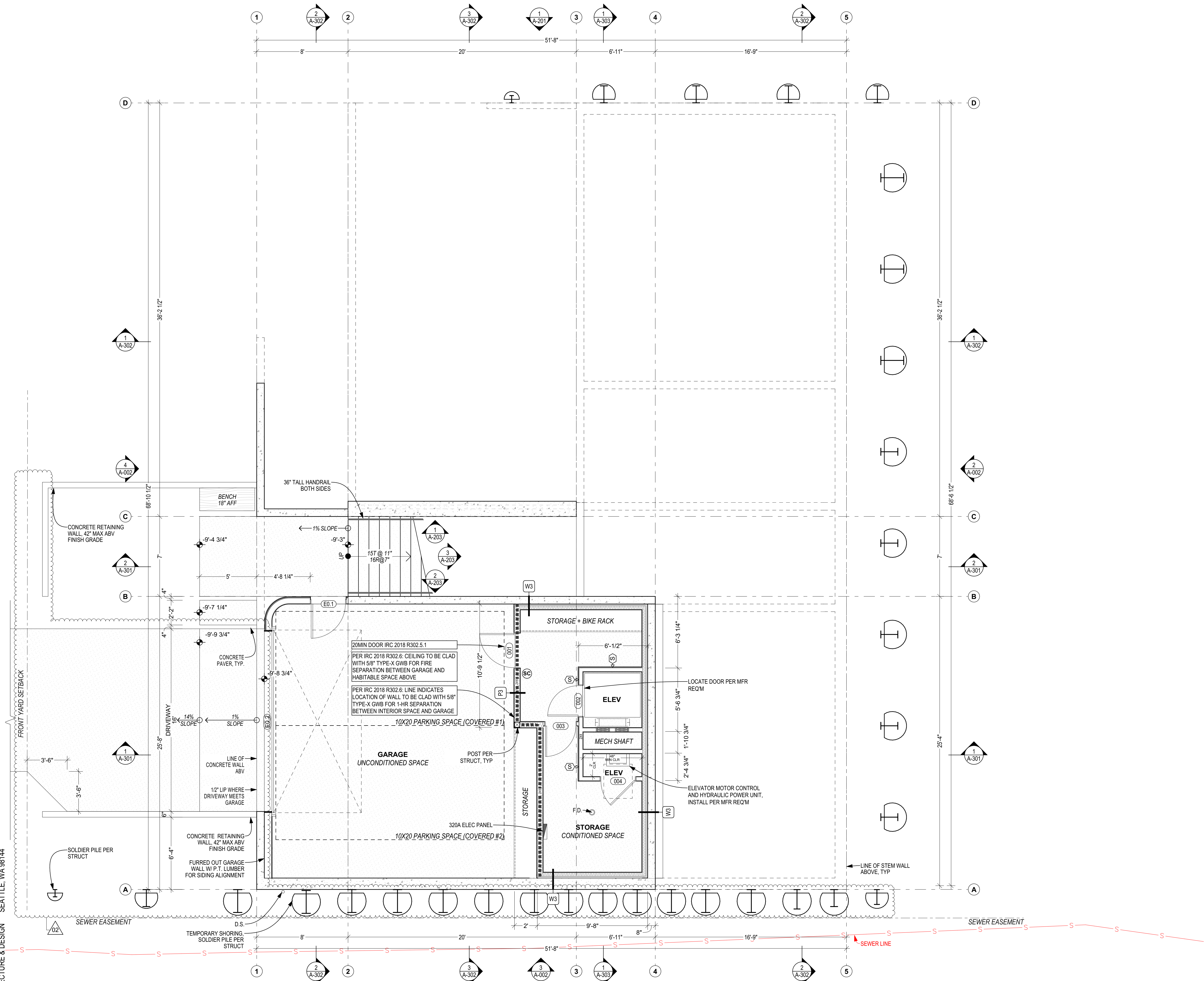

CONTACT
 SHED ARCHITECTURE & DESIGN
 1401 S JACKSON ST
 SEATTLE, WA 98144
 206.320.8700

PROJECT
SULLIVAN
 3024 69th Ave SE
 MERCER ISLAND, WA 98040

ISSUE	DATE
PRE APP #1 (PRE22-0433)	2022.08.16
CAR 2 (CAO22-023)	2022.12.08
PERMIT SET	2023.01.20
REVISION #1	2023.05.26
REVISION #2	2023.07.07

DRAWING TITLE
 GARAGE FLOOR PLAN

PLAN NOTES:	
A.	ALL DIMS ARE TO F.O. FRAMING OR F.O. CONC. U.N.O.
B.	ALL INDICATED ALIGNMENTS ARE TO F.O. FINISH, U.N.O.
C.	WINDOW OPENING DIMENSIONS ARE MEASURED FROM THE ROUGH OPENING U.N.O. -- RE: SCHEDULES & ELEVATIONS FOR ADDITIONAL INFO.
D.	RE: STRUCTURAL FOR FRAMING INFO.
E.	ALL FLOOR TRANSITIONS SHALL BE AT CENTER OF DOOR LEAF, U.N.O.
F.	ALL INTERIOR PARTITIONS ARE P2 U.N.O.

SYMBOL LEGEND:	
	MAIN ENTRY DOOR
	COMBINATION SMOKE & CARBON MONOXIDE ALARM
	50 CFM (U.N.O.) EXHAUST FAN
	INDICATES SIDE OF SHEAR WALL TO RECEIVE SHEATHING (RE: STRUCT FOR MORE INFO)
	ASSEMBLY TAG, REFER TO A-601 FOR MORE INFO

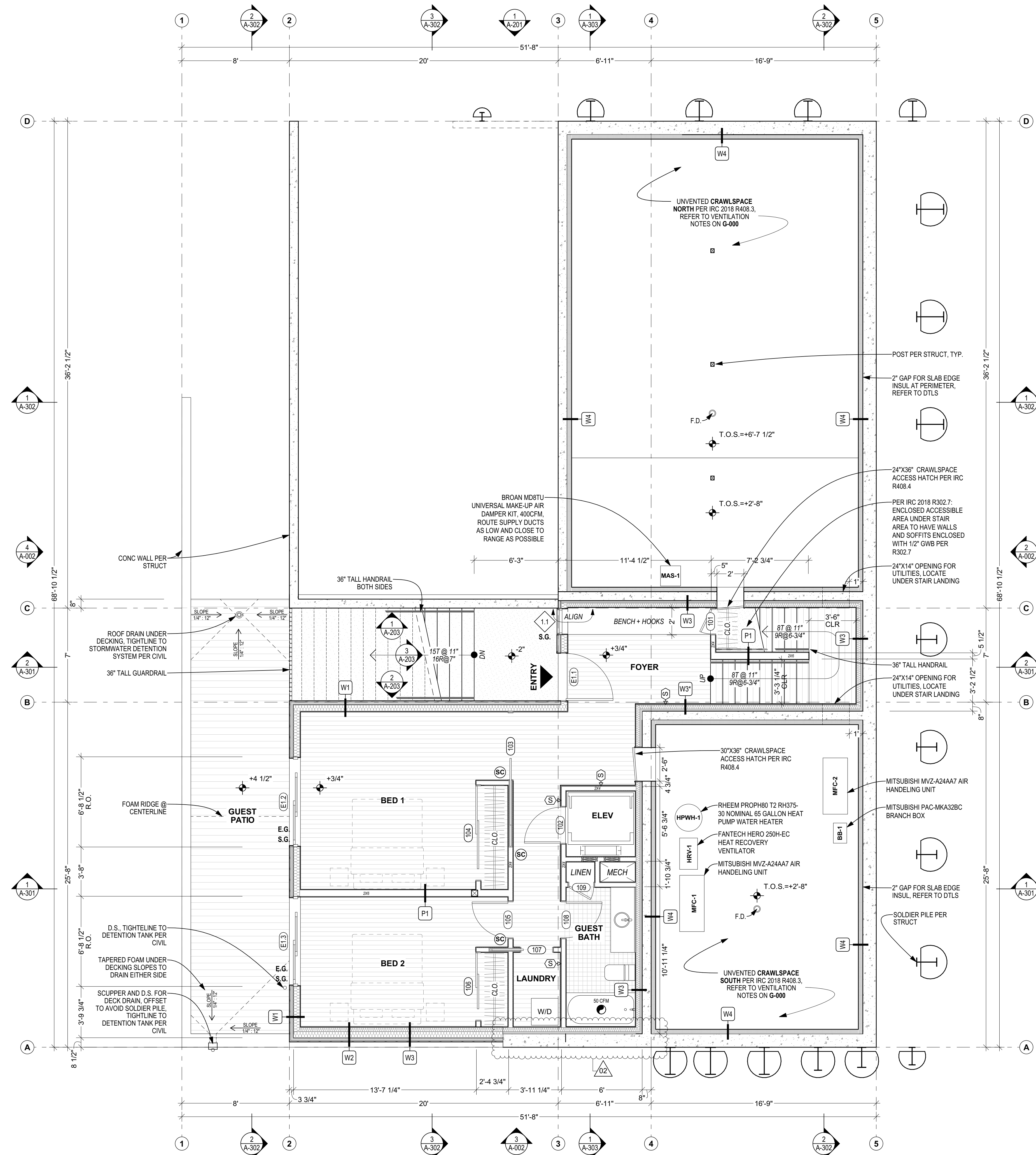

CONTACT
 SHED ARCHITECTURE & DESIGN
 1401 S JACKSON ST
 SEATTLE, WA 98144
 206.320.8700

PROJECT
 SULLIVAN
 3024 69th Ave SE
 MERCER ISLAND, WA 98040

ISSUE	DATE
PRE APP #1 (PRE22-0433)	2022.08.16
CAR 2 (CA022-023)	2022.12.08
PERMIT SET	2023.01.20
REVISION #1	2023.05.26
REVISION #2	2023.07.07

DRAWING TITLE
 LEVEL 1 FLOOR PLAN

PLAN NOTES:	
A.	ALL DIMS ARE TO F.O. FRAMING OR F.O. CONC. U.N.O.
B.	ALL INDICATED ALIGNMENTS ARE TO F.O. FINISH, U.N.O.
C.	WINDOW OPENING DIMENSIONS ARE MEASURED FROM THE ROUGH OPENING U.N.O. -- RE: SCHEDULES & ELEVATIONS FOR ADDITIONAL INFO.
D.	RE: STRUCTURAL FOR FRAMING INFO.
E.	ALL FLOOR TRANSITIONS SHALL BE AT CENTER OF DOOR LEAF, U.N.O.
F.	ALL INTERIOR PARTITIONS ARE P2 U.N.O.

SYMBOL LEGEND:	
	MAIN ENTRY DOOR
	COMBINATION SMOKE & CARBON MONOXIDE ALARM
	50 CFM (U.N.O.) EXHAUST FAN
	INDICATES SIDE OF SHEAR WALL TO RECEIVE SHEATHING (RE: STRUCT FOR MORE INFO)
	ASSEMBLY TAG, REFER TO A-601 FOR MORE INFO

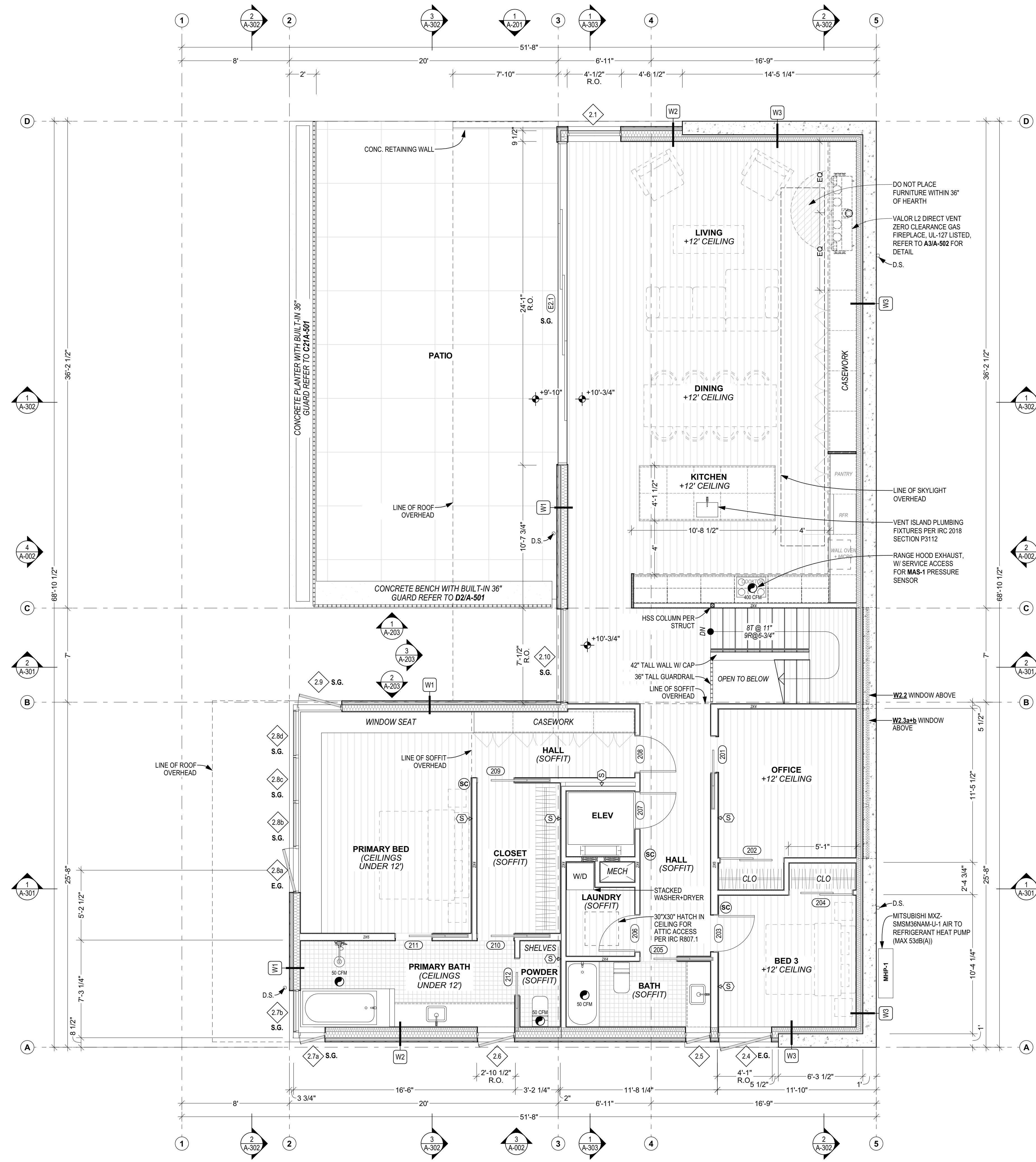

CONTACT
 SHED ARCHITECTURE & DESIGN
 1401 S JACKSON ST
 SEATTLE, WA 98144
 206.320.8700

PROJECT
SULLIVAN
 3024 69th Ave SE
 MERCER ISLAND, WA 98040

ISSUE	DATE
PRE APP #1 (PRE22-0433)	2022.08.16
CAR 2 (CAO22-023)	2022.12.08
PERMIT SET	2023.01.20
REVISION #1	2023.05.26
REVISION #2	2023.07.07

DRAWING TITLE
LEVEL 2 FLOOR PLAN

PLAN NOTES:	
A.	ALL DIMS ARE TO F.O. FRAMING OR F.O. CONC. U.N.O.
B.	ALL INDICATED ALIGNMENTS ARE TO F.O. FINISH, U.N.O.
C.	WINDOW OPENING DIMENSIONS ARE MEASURED FROM THE ROUGH OPENING U.N.O. -- RE: SCHEDULES & ELEVATIONS FOR ADDITIONAL INFO.
D.	RE: STRUCTURAL FOR FRAMING INFO.
E.	ALL FLOOR TRANSITIONS SHALL BE AT CENTER OF DOOR LEAF, U.N.O.
F.	ALL INTERIOR PARTITIONS ARE P2 U.N.O.

SYMBOL LEGEND:	
	MAIN ENTRY DOOR
	COMBINATION SMOKE & CARBON MONOXIDE ALARM
	50 CFM (U.N.O.) EXHAUST FAN
	INDICATES SIDE OF SHEAR WALL TO RECEIVE SHEATHING (RE: STRUCT FOR MORE INFO)
	ASSEMBLY TAG, REFER TO A-601 FOR MORE INFO

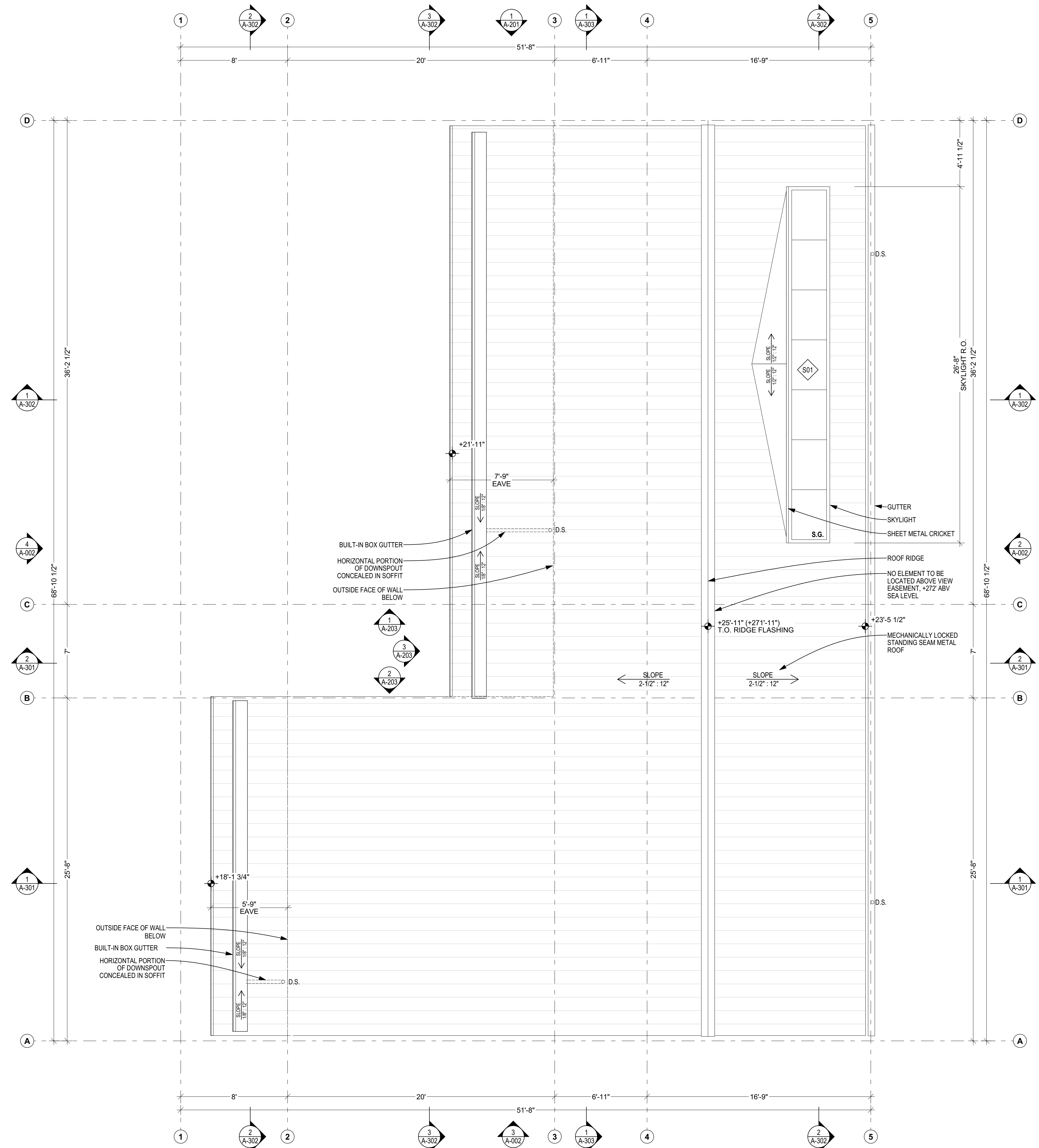

© SHED ARCHITECTURE & DESIGN SEATTLE, WA 98144

1 ROOF PLAN
SCALE: 1/4" = 1'-0"

CONTACT
SHED ARCHITECTURE & DESIGN
1401 S JACKSON ST
SEATTLE, WA 98144
206.320.8700

PROJECT
SULLIVAN
3024 69th Ave SE
MERCER ISLAND, WA 98040

ISSUE	DATE
PRE APP #1 (PRE22-0433)	2022.08.16
CAR 2 (CAO22-023)	2022.12.08
PERMIT SET	2023.01.20
REVISION #1	2023.05.26
REVISION #2	2023.07.07

DRAWING TITLE
ROOF PLAN



A-113

ELEVATION NOTES:	
A.	ALL DIMS ARE TO FACE OF FINISH U.O.
B.	FLOOR ELEVATIONS REFERENCE TOP OF STRUCTURAL FLOOR DIAPHRAM; RE: ASSEMBLIES ON A-601
FINISH LEGEND:	
SD-1	HORIZONTAL CEDAR SIDING
MTL-1	STANDING SEAM METAL ROOF
MTL-2	INFILL METAL PANEL
CN-1	ARCHITECTURAL CONCRETE WALL

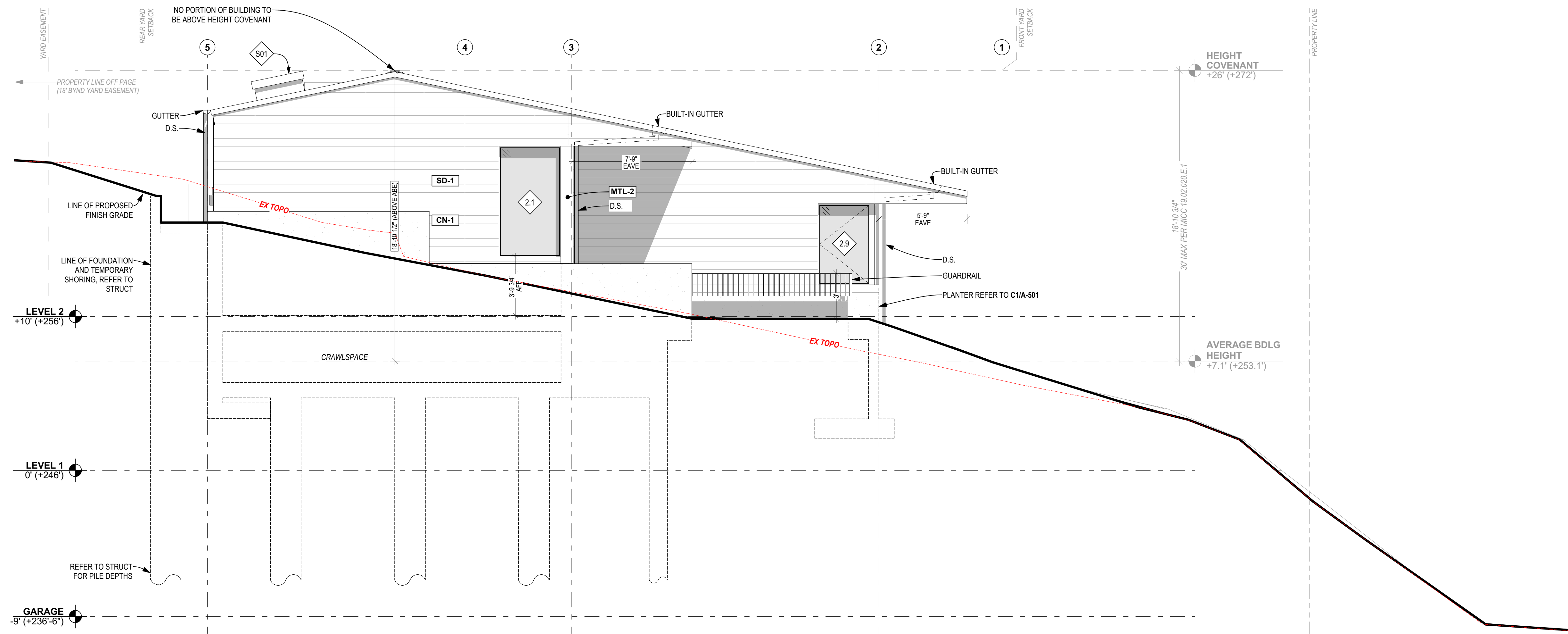

1 NORTH ELEVATION
SCALE: 1/4" = 1'-0"

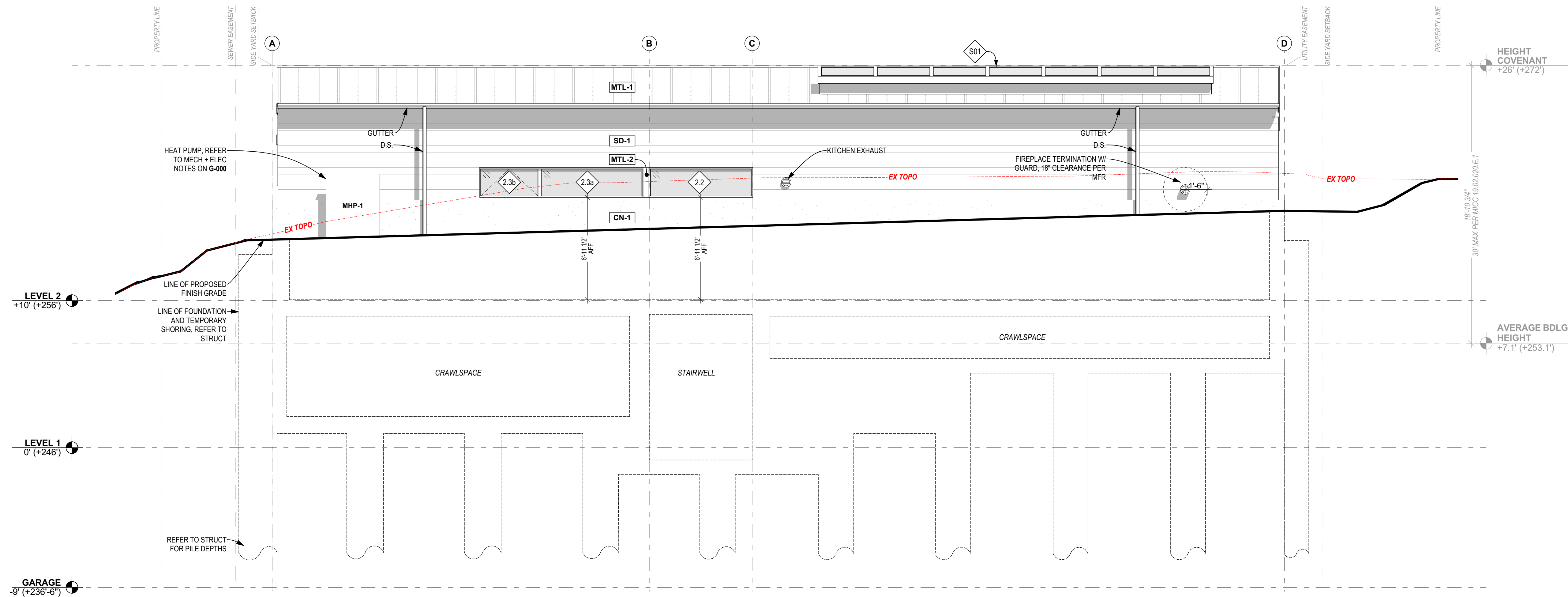

2 EAST ELEVATION
SCALE: 1/4" = 1'-0"



CONTACT
SHED ARCHITECTURE & DESIGN
1401 S JACKSON ST
SEATTLE, WA 98144
206.320.8700

PROJECT
SULLIVAN
3024 69th Ave SE
MERCER ISLAND, WA 98040

ISSUE	DATE
PRE APP #1 (PRE22-0433)	2022.08.16
CAR 2 (CAO22-023)	2022.12.08
PERMIT SET	2023.01.20
REVISION #1	2023.05.26
REVISION #2	2023.07.07

DRAWING TITLE
EXTERIOR ELEVATIONS

ELEVATION NOTES:	
A.	ALL DIMS ARE TO FACE OF FINISH U.O.
B.	FLOOR ELEVATIONS REFERENCE TOP OF STRUCTURAL FLOOR DIAPHRAM; RE. ASSEMBLIES ON A-601
FINISH LEGEND:	
SD-1	HORIZONTAL CEDAR SIDING
MTL-1	STANDING SEAM METAL ROOF
MTL-2	INFILL METAL PANEL
CN-1	ARCHITECTURAL CONCRETE WALL

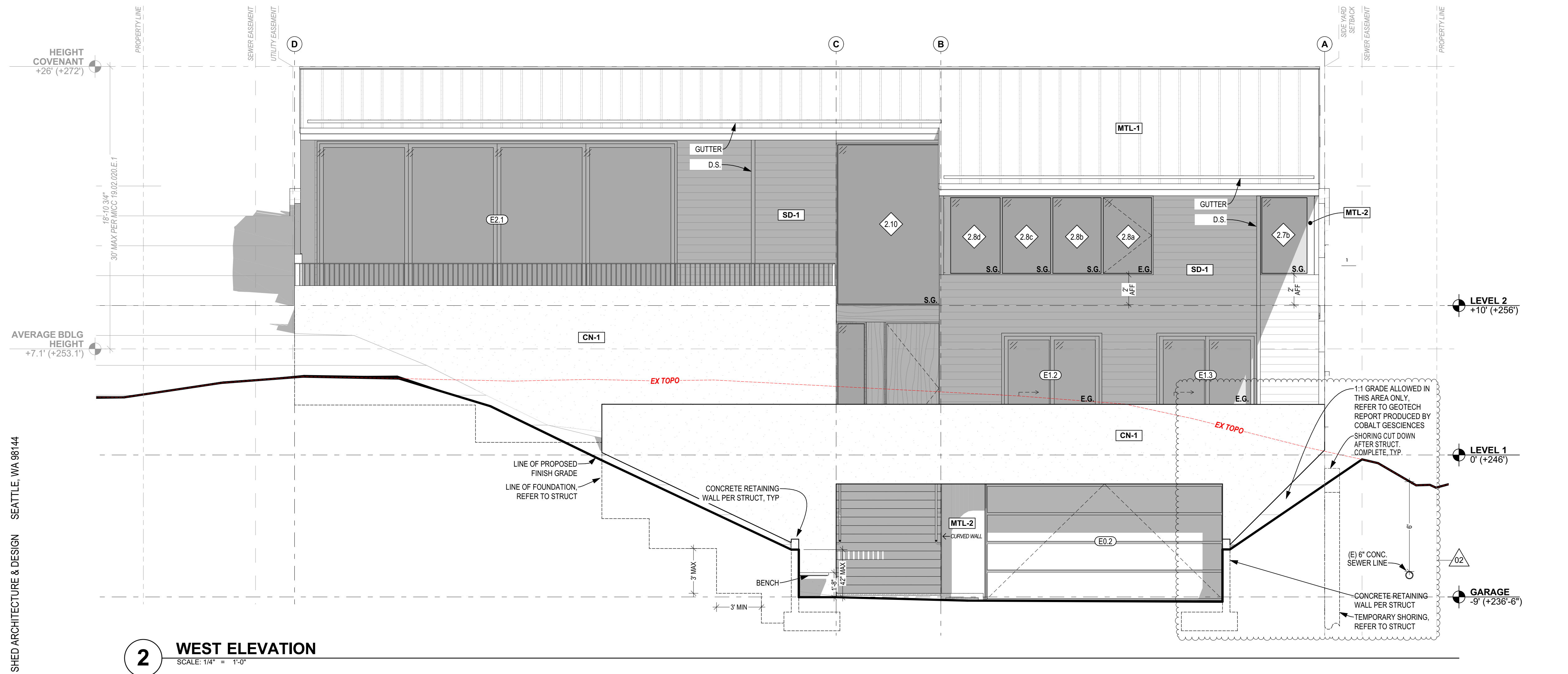
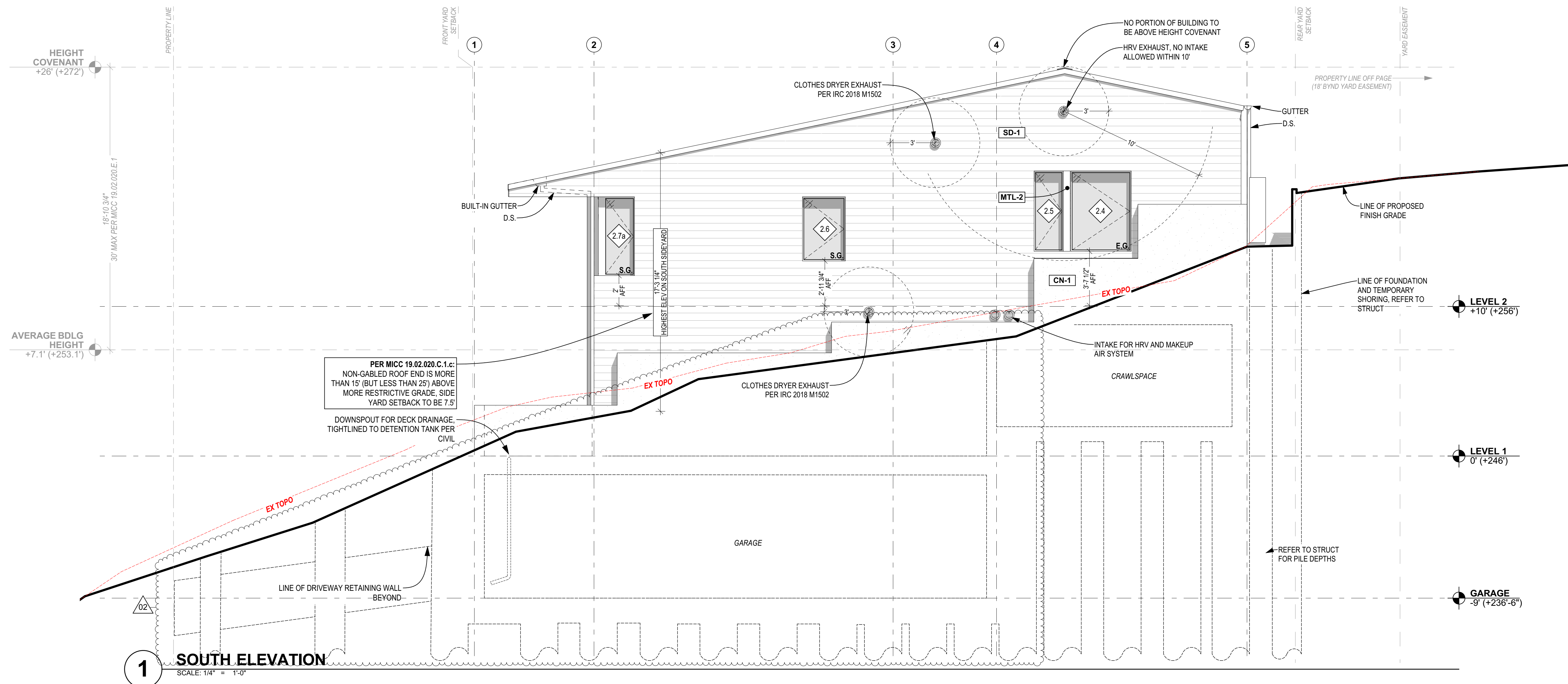

CONTACT
SHED ARCHITECTURE & DESIGN
1401 S JACKSON ST
SEATTLE, WA 98144
206.320.8700

PROJECT
SULLIVAN
3024 69th Ave SE
MERCER ISLAND, WA 98040

ISSUE	DATE
PRE APP #1 (PRE22-0433)	2022.08.16
CAR 2 (CAO22-023)	2022.12.08
PERMIT SET	2023.01.20
REVISION #1	2023.05.26
REVISION #2	2023.07.07

DRAWING TITLE
EXTERIOR ELEVATIONS

ELEVATION NOTES:	
A.	ALL DIMS ARE TO FACE OF FINISH U.N.O.
B.	FLOOR ELEVATIONS REFERENCE TOP OF STRUCTURAL FLOOR DIAPHRAM; RE. ASSEMBLIES ON A-601
FINISH LEGEND:	
SD-1	HORIZONTAL CEDAR SIDING
MTL-1	STANDING SEAM METAL ROOF
MTL-2	INFILL METAL PANEL
CN-1	ARCHITECTURAL CONCRETE WALL

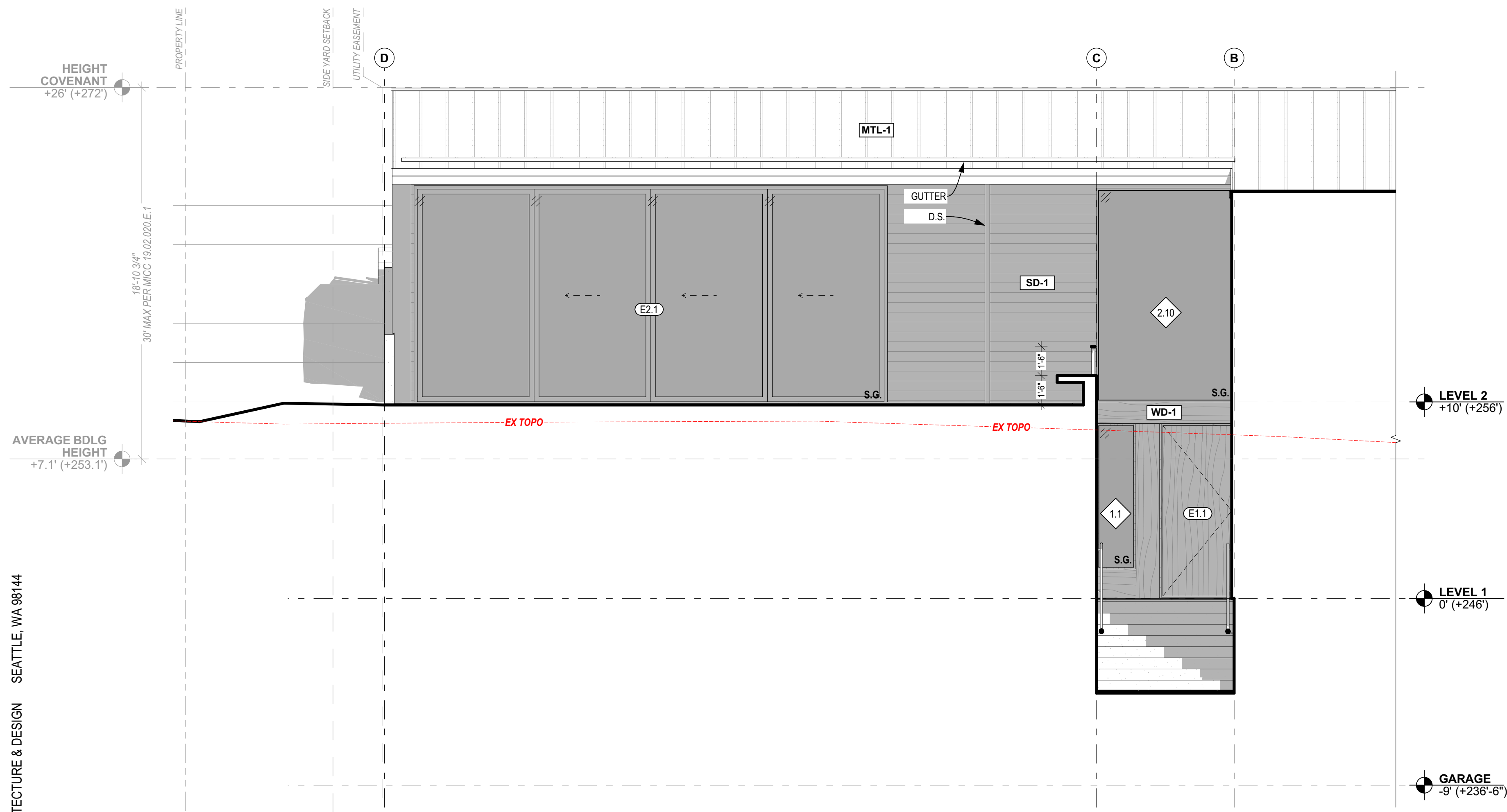
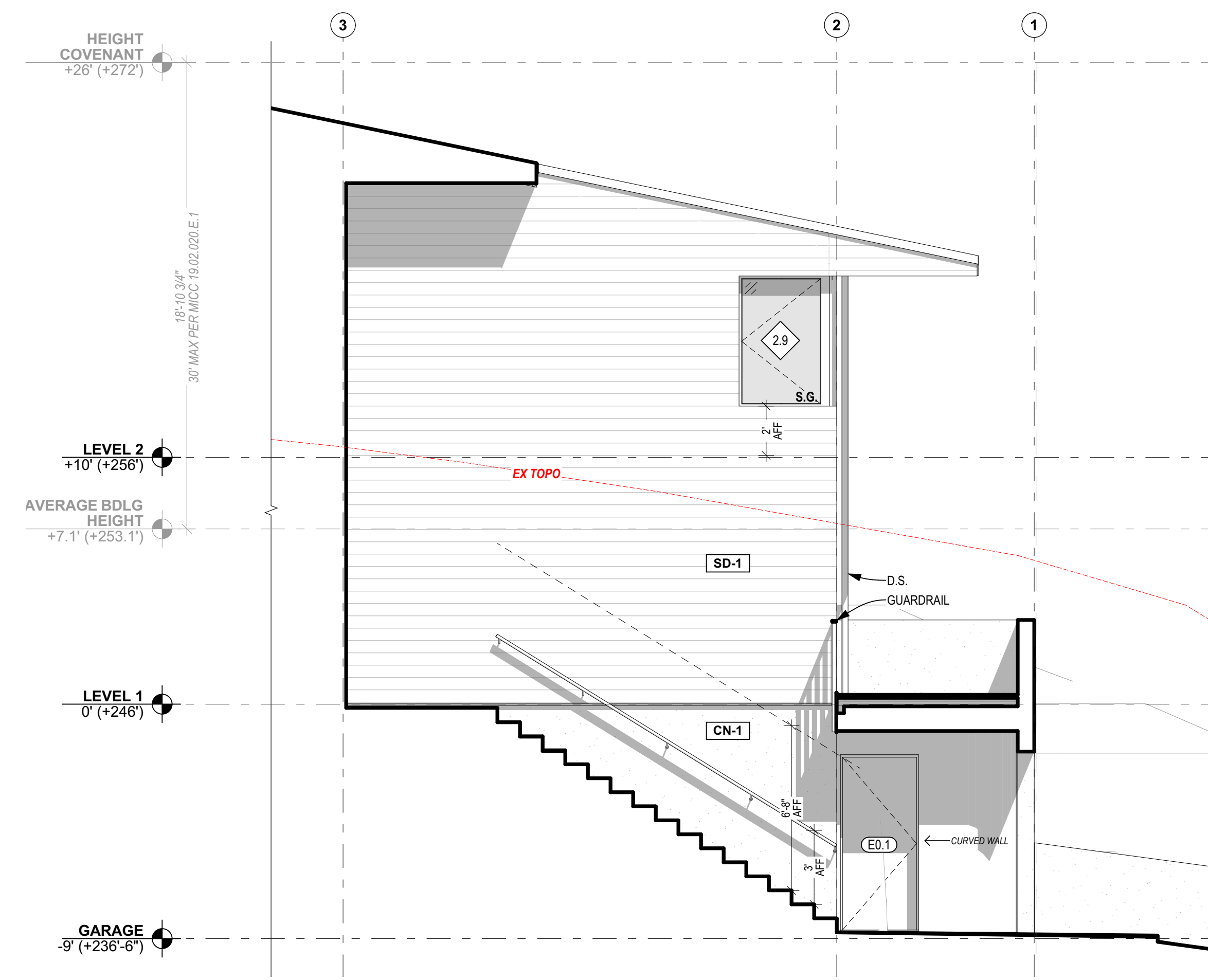
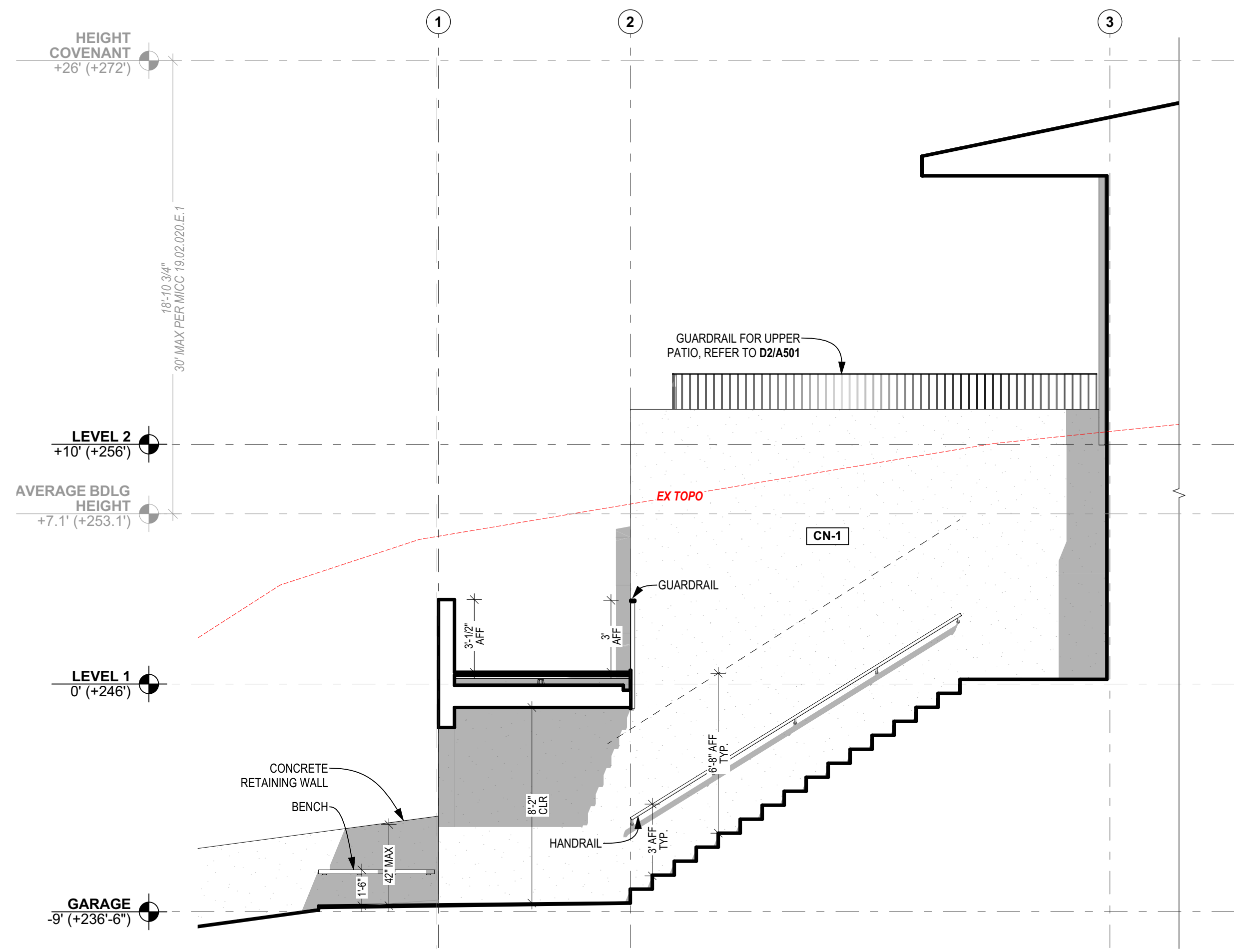

CONTACT
SHED ARCHITECTURE & DESIGN
1401 S JACKSON ST
SEATTLE, WA 98144
206.320.8700

PROJECT
SULLIVAN
3024 69th Ave SE
MERCER ISLAND, WA 98040

ISSUE	DATE
PRE APP #1 (PRE22-0433)	2022.08.16
CAR 2 (CAO22-023)	2022.12.08
PERMIT SET	2023.01.20
REVISION #1	2023.05.26
REVISION #2	2023.07.07

DRAWING TITLE
EXTERIOR ELEVATIONS

SECTION NOTES:	
A.	FLOOR ELEVATIONS REFERENCE TOP OF STRUCTURAL FLOOR DIAPHRAM; RE: ASSEMBLIES.
B.	RE: SHEET A-601 FOR TYP. ASSEMBLIES.

SECTION LEGEND:	
	LINE OF CONTINUOUS AIR BARRIER
	LINE OF EXISTING GRADE
	LINE OF PROPOSED FINISH GRADE
	NATIVE SOIL
	BACKFILL, REFER TO GEOTECH REPORT

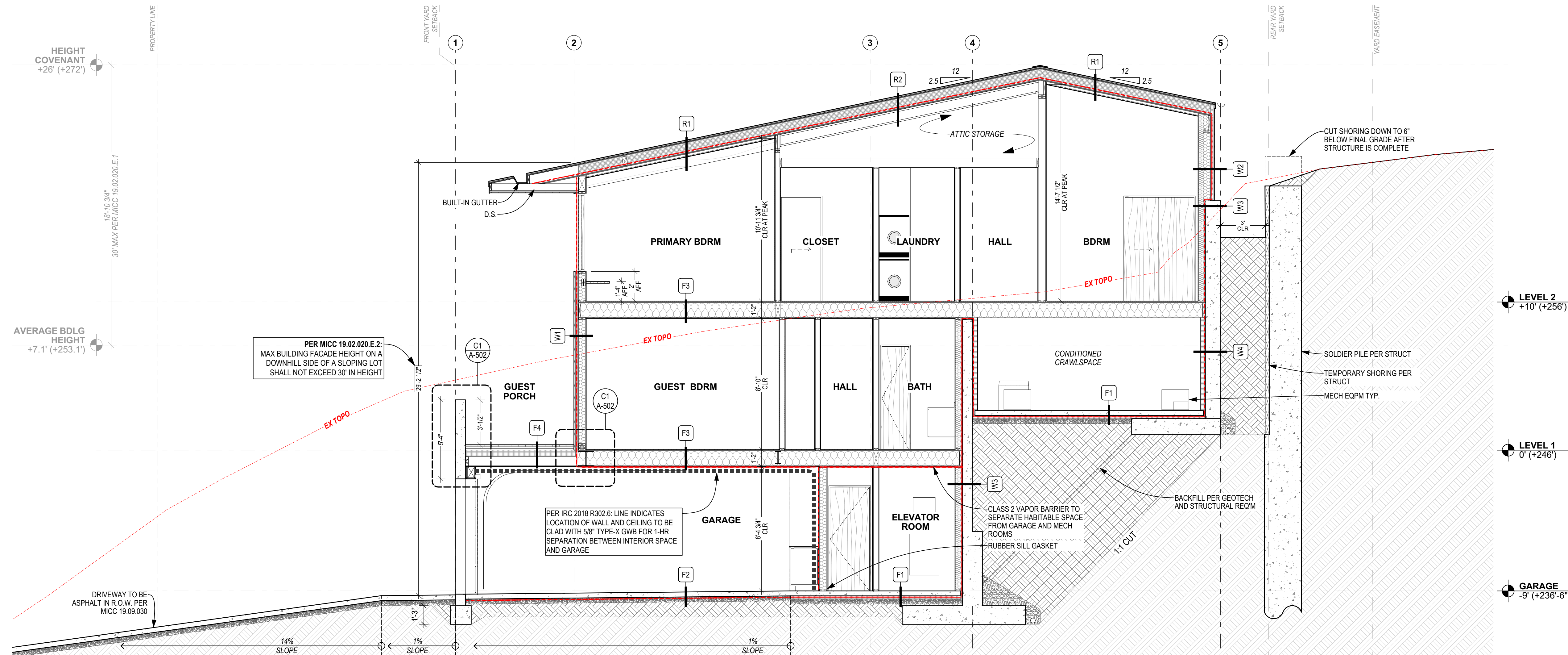

1 EAST WEST SECTION // GARAGE & BEDROOMS
SCALE: 1/4" = 1'-0"

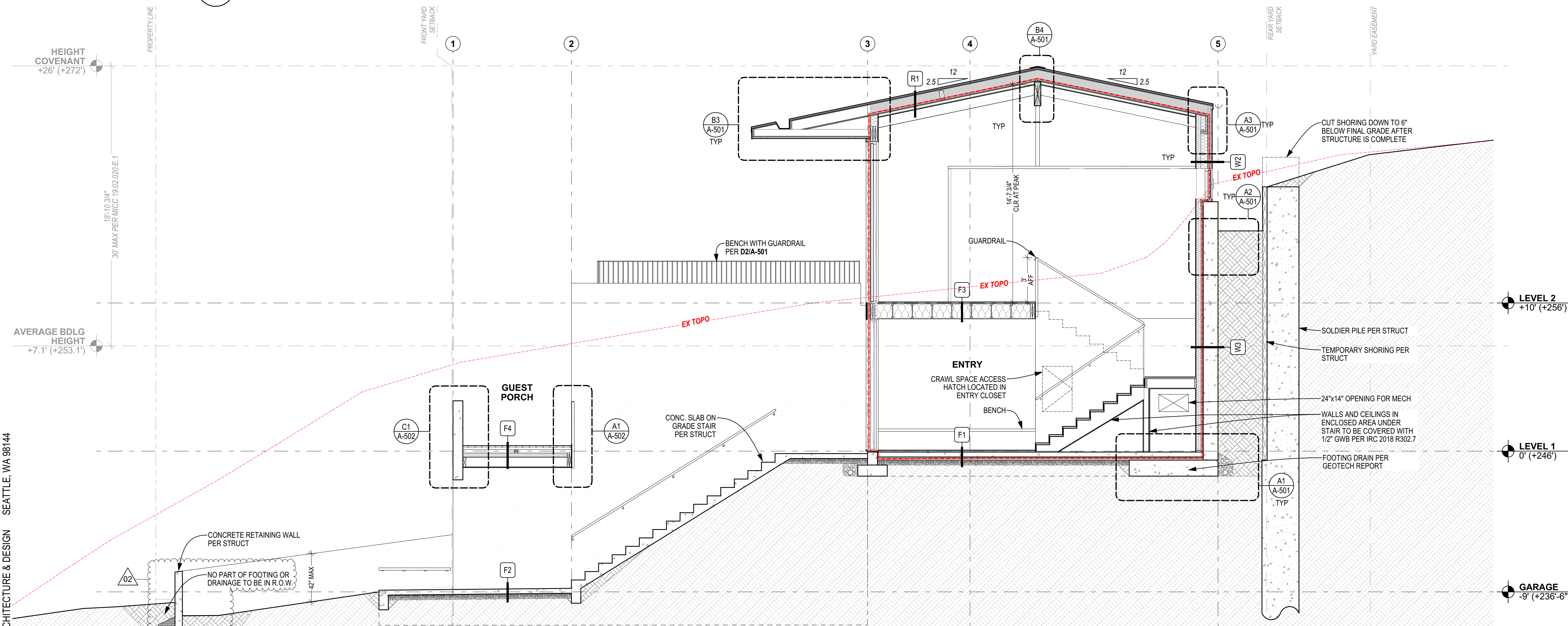

2 EAST WEST SECTION // GUEST PORCH & ENTRY
SCALE: 1/4" = 1'-0"

CONTACT
SHED ARCHITECTURE & DESIGN
1401 S JACKSON ST
SEATTLE, WA 98144
206.320.8700

PROJECT
SULLIVAN
3024 69th Ave SE
MERCER ISLAND, WA 98040

ISSUE	DATE
PRE APP #1 (PRE22-0433)	2022.08.16
CAR 2 (CAO22-023)	2022.12.08
PERMIT SET	2023.01.20
REVISION #1	2023.05.26
REVISION #2	2023.07.07

DRAWING TITLE
BLDG SECTIONS

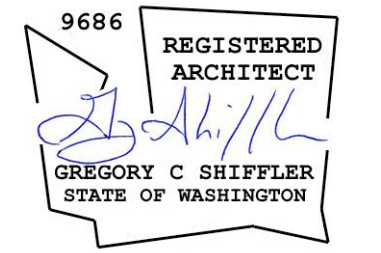

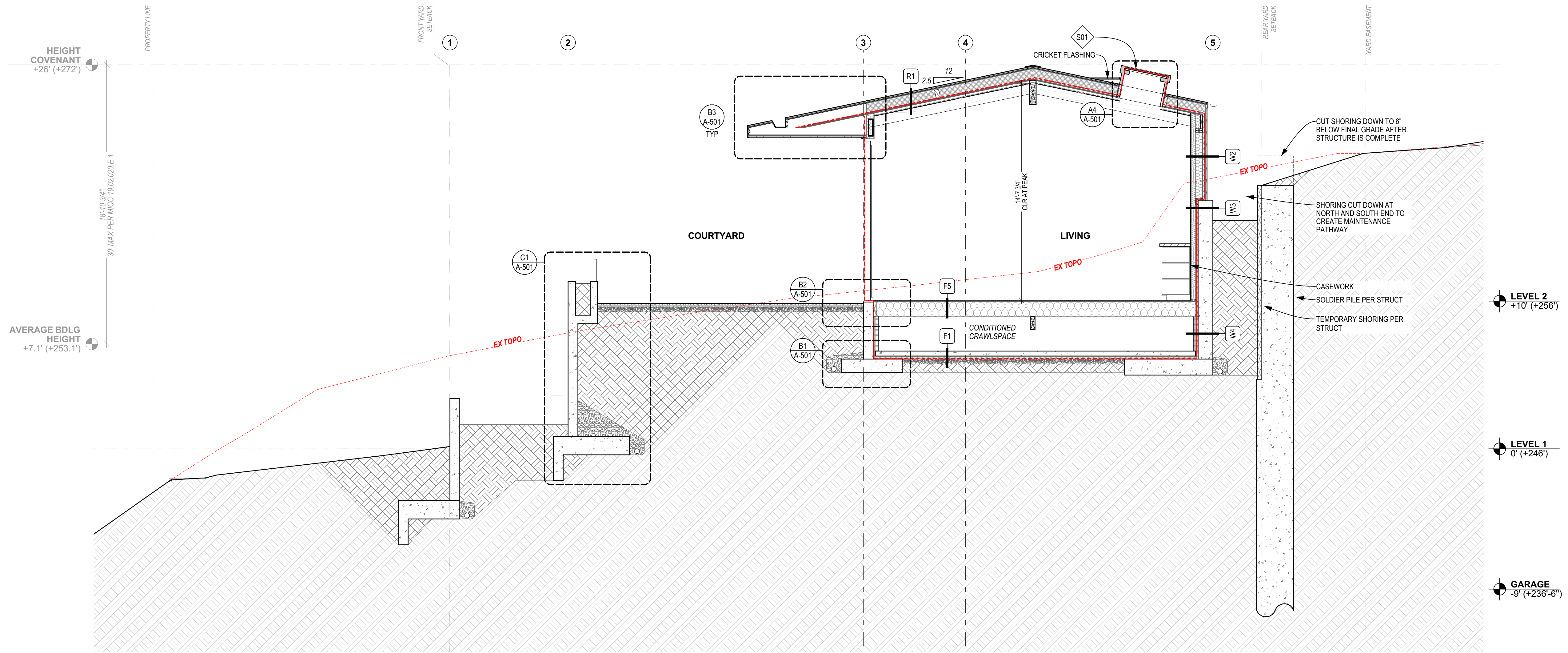

SECTION NOTES:

A. FLOOR ELEVATIONS REFERENCE TOP OF STRUCTURAL FLOOR DIAPHRAM; RE: ASSEMBLIES.
 B. RE: SHEET A-601 FOR TYP. ASSEMBLIES.

SECTION LEGEND:

- LINE OF CONTINUOUS AIR BARRIER
- - - EX TOPO --- LINE OF EXISTING GRADE
- LINE OF PROPOSED FINISH GRADE
- [Hatched Pattern] NATIVE SOIL
- [Cross-hatched Pattern] BACKFILL, REFER TO GEOTECH REPORT

1 EAST WEST SECTION // UPPER PATIO & LIVING
 SCALE: 1/4" = 1'-0"

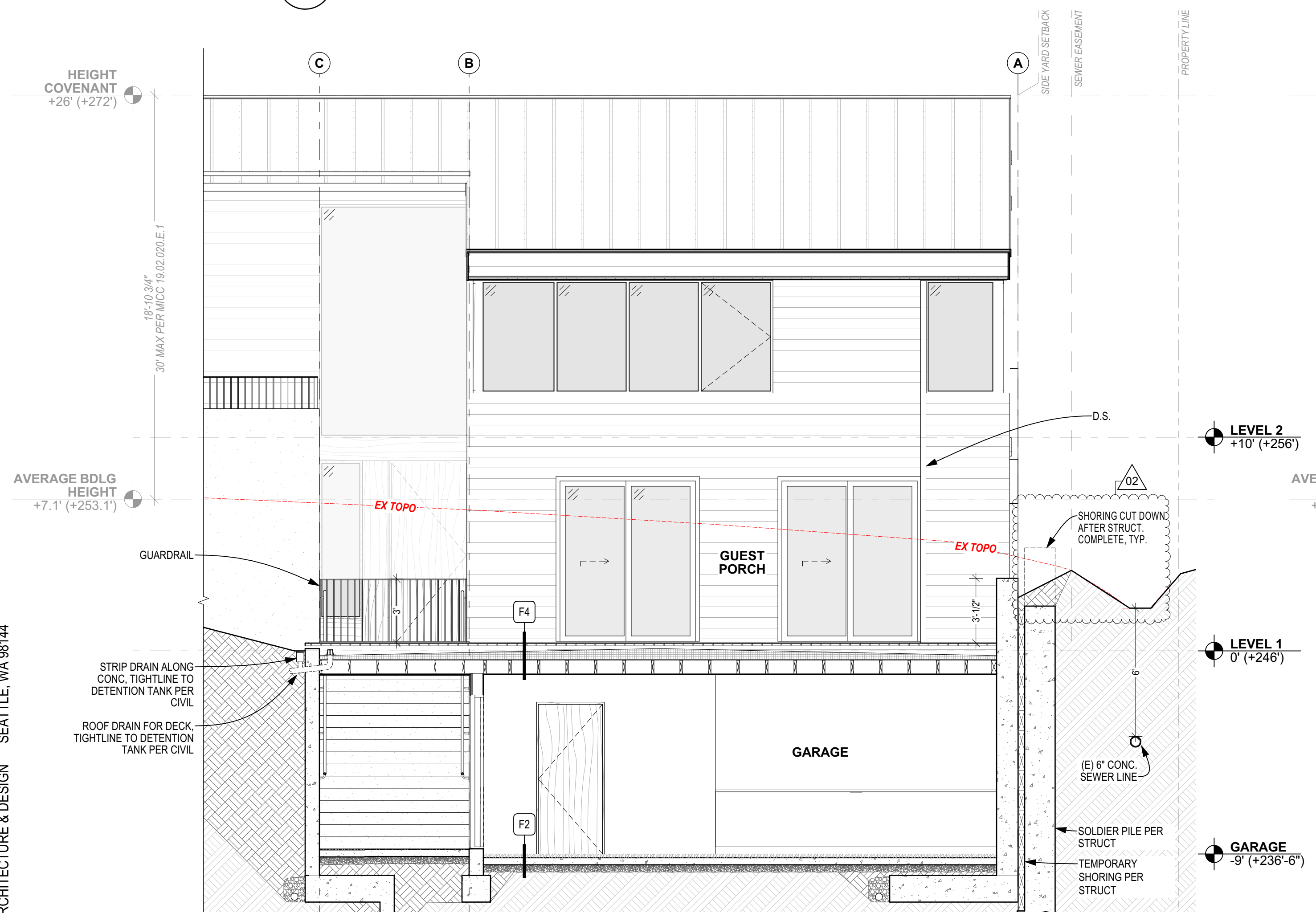

2 NORTH SOUTH SECTION // GARAGE + GUEST PORCH
 SCALE: 1/4" = 1'-0"

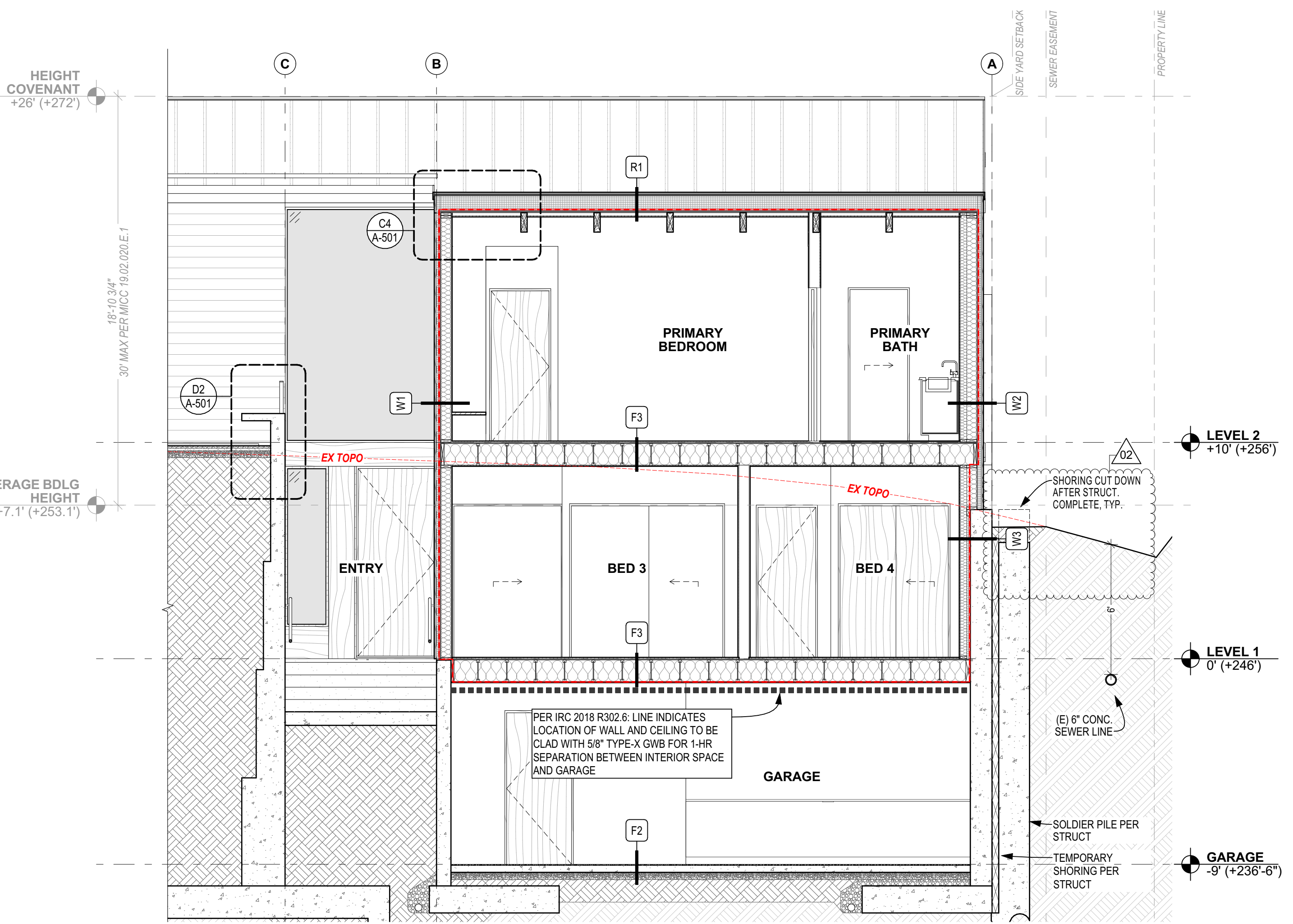

3 NORTH SOUTH SECTION // ENTRY STAIR + BEDROOMS
 SCALE: 1/4" = 1'-0"



CONTACT
 SHED ARCHITECTURE & DESIGN
 1401 S JACKSON ST
 SEATTLE, WA 98144
 206.320.8700

PROJECT
 SULLIVAN
 3024 69th Ave SE
 MERCER ISLAND, WA 98040

ISSUE	DATE
PRE APP #1 (PRE22-0433)	2022.08.16
CAR 2 (CAO22-023)	2022.12.08
PERMIT SET	2023.01.20
REVISION #1	2023.05.26
REVISION #2	2023.07.07

DRAWING TITLE
 BLDG SECTIONS

A-302

SECTION NOTES:	
A.	FLOOR ELEVATIONS REFERENCE TOP OF STRUCTURAL FLOOR DIAPHRAM; RE: ASSEMBLIES.
B.	RE: SHEET A-601 FOR TYP. ASSEMBLIES.
SECTION LEGEND:	
	LINE OF CONTINUOUS AIR BARRIER
	LINE OF EXISTING GRADE
	LINE OF PROPOSED FINISH GRADE
	NATIVE SOIL
	BACKFILL, REFER TO GEOTECH REPORT

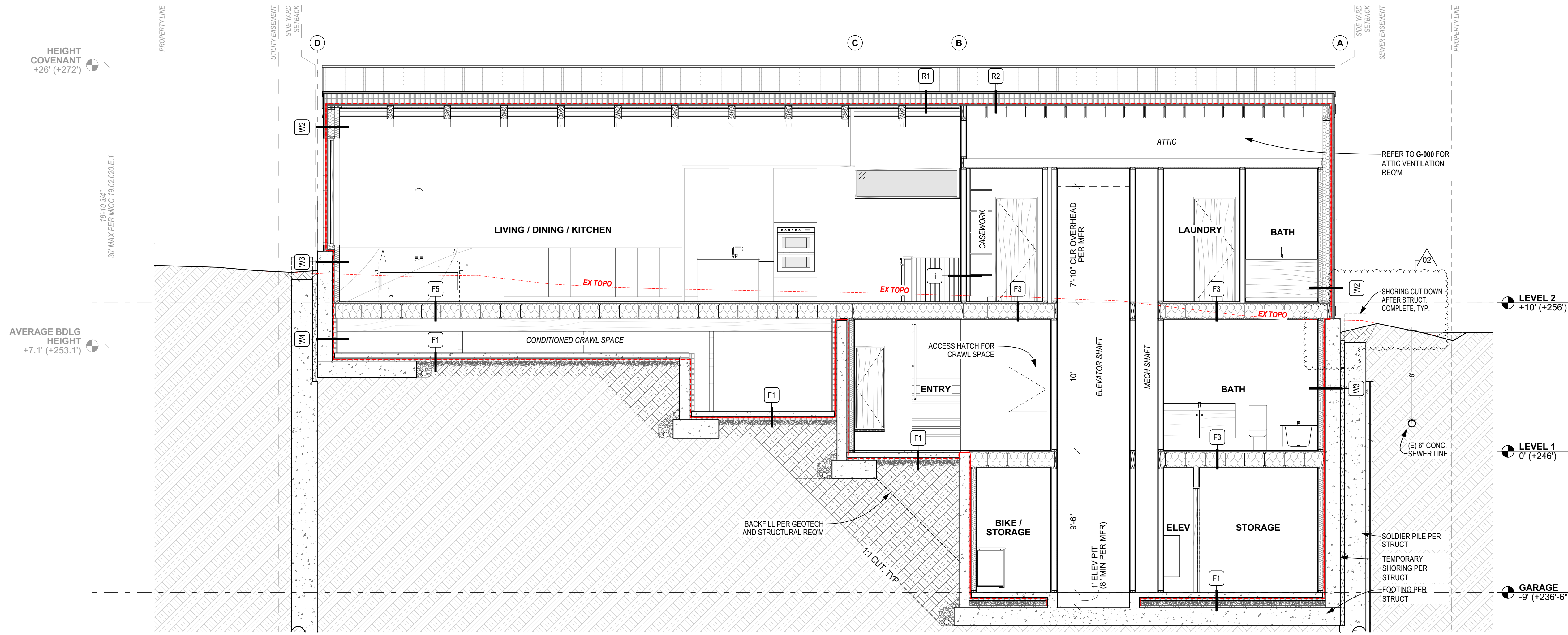

1 NORTH SOUTH SECTION // LDK & ELEVATOR
SCALE: 1/4" = 1'-0"

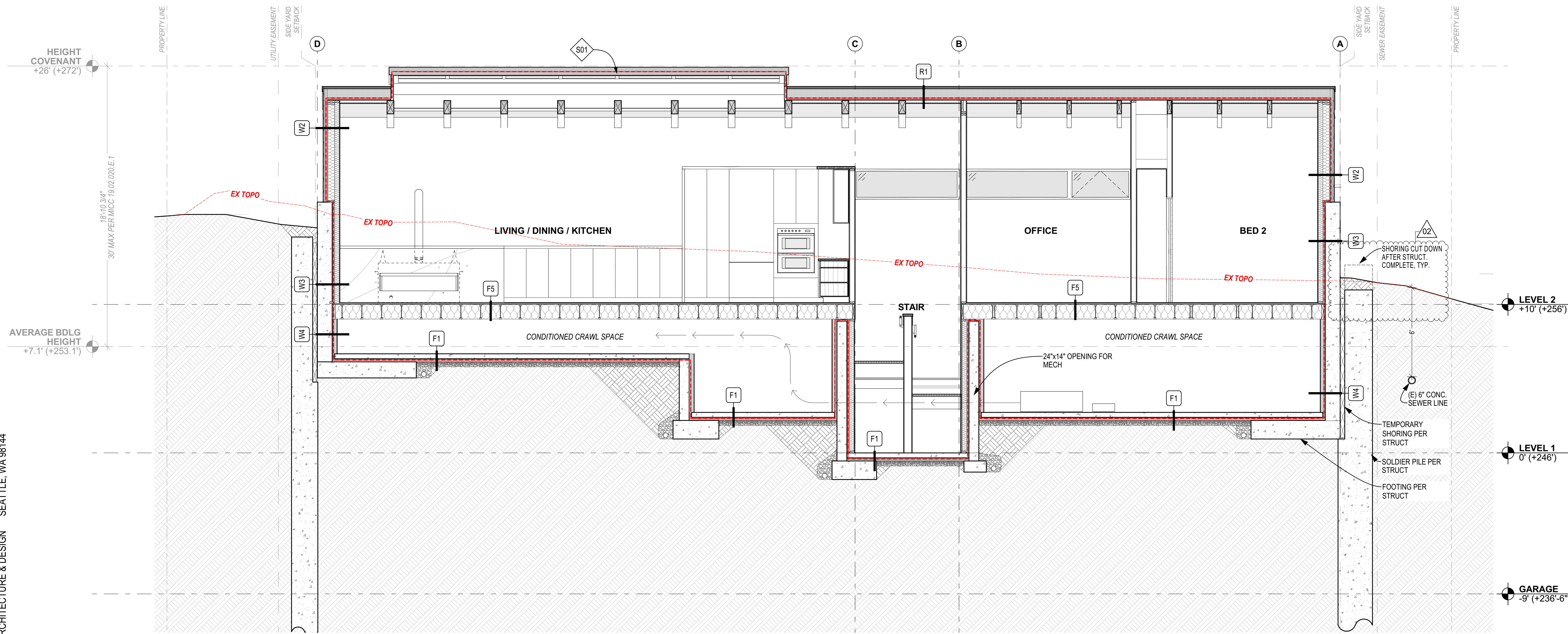

2 NORTH SOUTH SECTION // LDK & OFFICE
SCALE: 1/4" = 1'-0"

CONTACT
SHED ARCHITECTURE & DESIGN
1401 S JACKSON ST
SEATTLE, WA 98144
206.320.8700

PROJECT
SULLIVAN
3024 69th Ave SE
MERCER ISLAND, WA 98040

ISSUE	DATE
PRE APP #1 (PRE22-0433)	2022.08.16
CAR 2 (CAO22-023)	2022.12.08
PERMIT SET	2023.01.20
REVISION #1	2023.05.26
REVISION #2	2023.07.07

DRAWING TITLE
BLDG SECTIONS



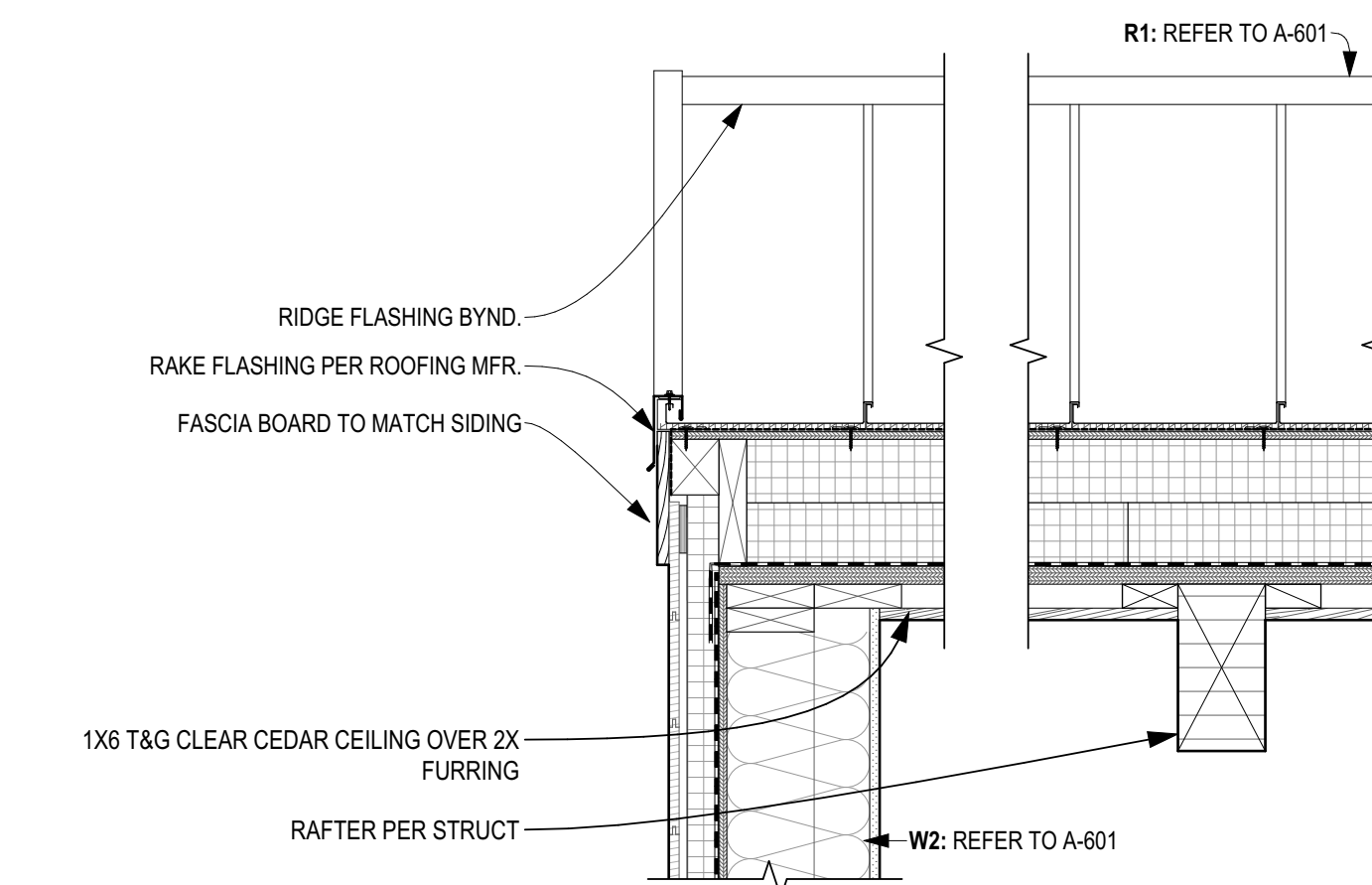

C4 TYP. RAKE
SCALE: 1" = 1'-0"

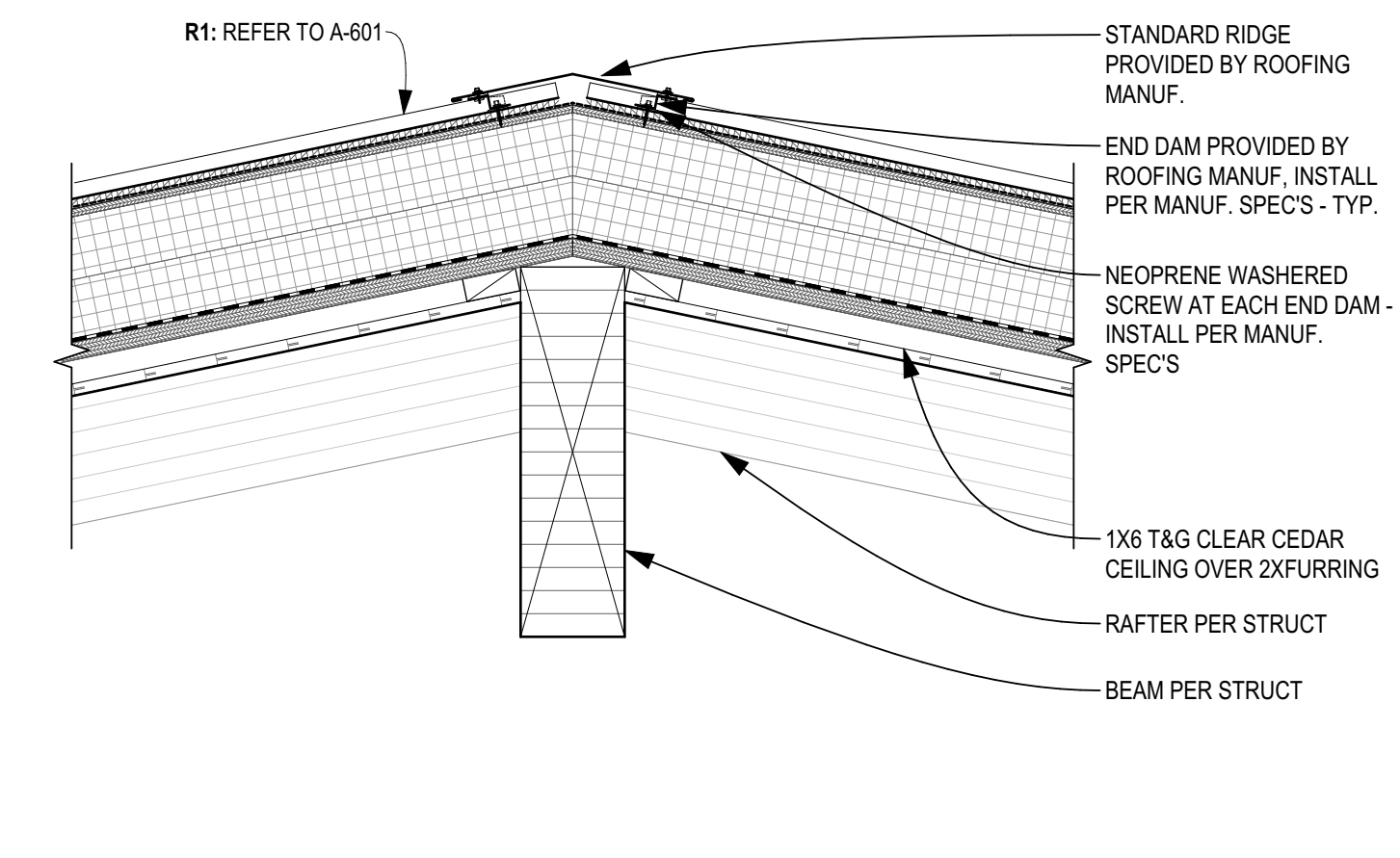

B4 TYP. RIDGE
SCALE: 1" = 1'-0"

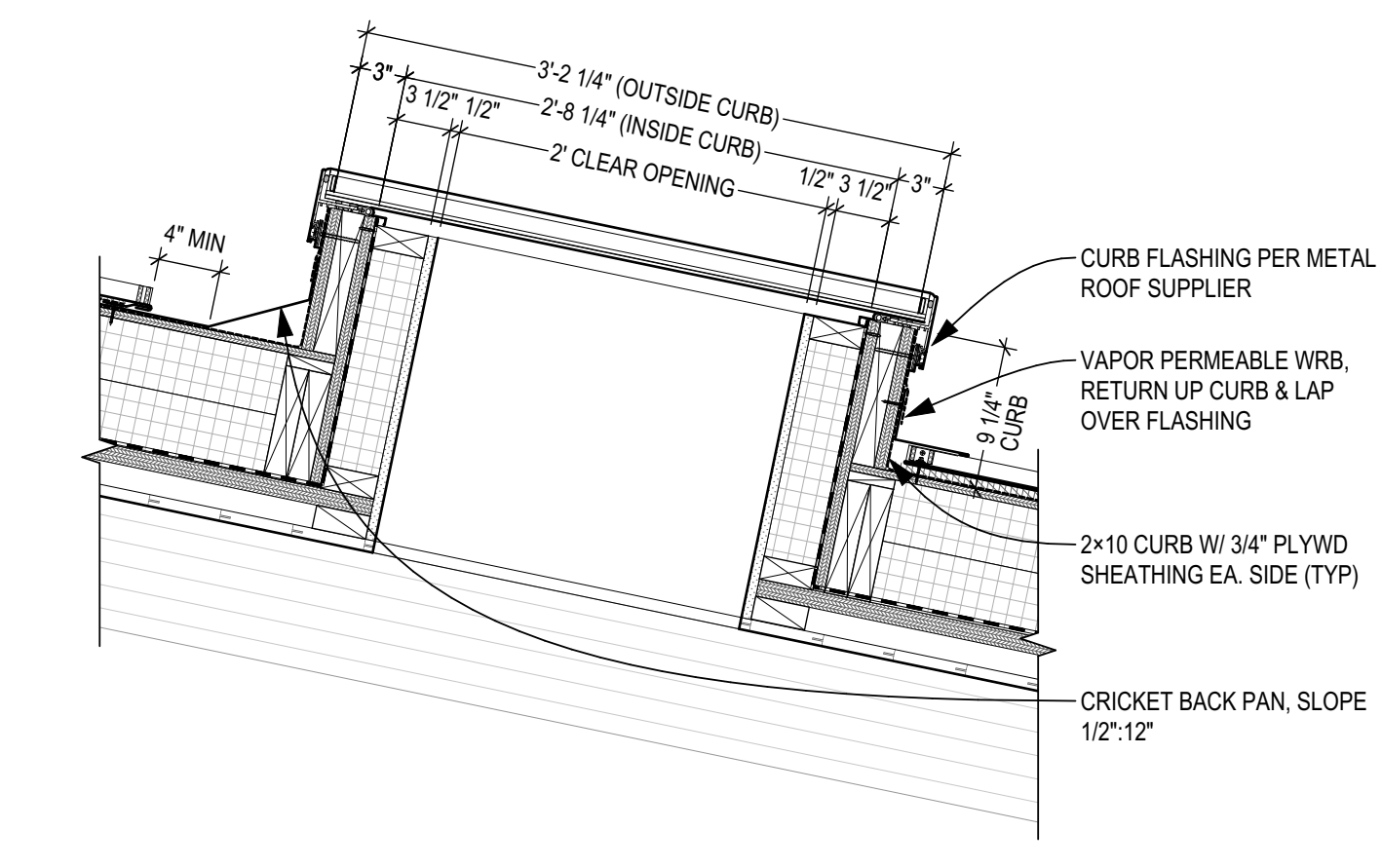

A4 SKYLIGHT
SCALE: 1" = 1'-0"

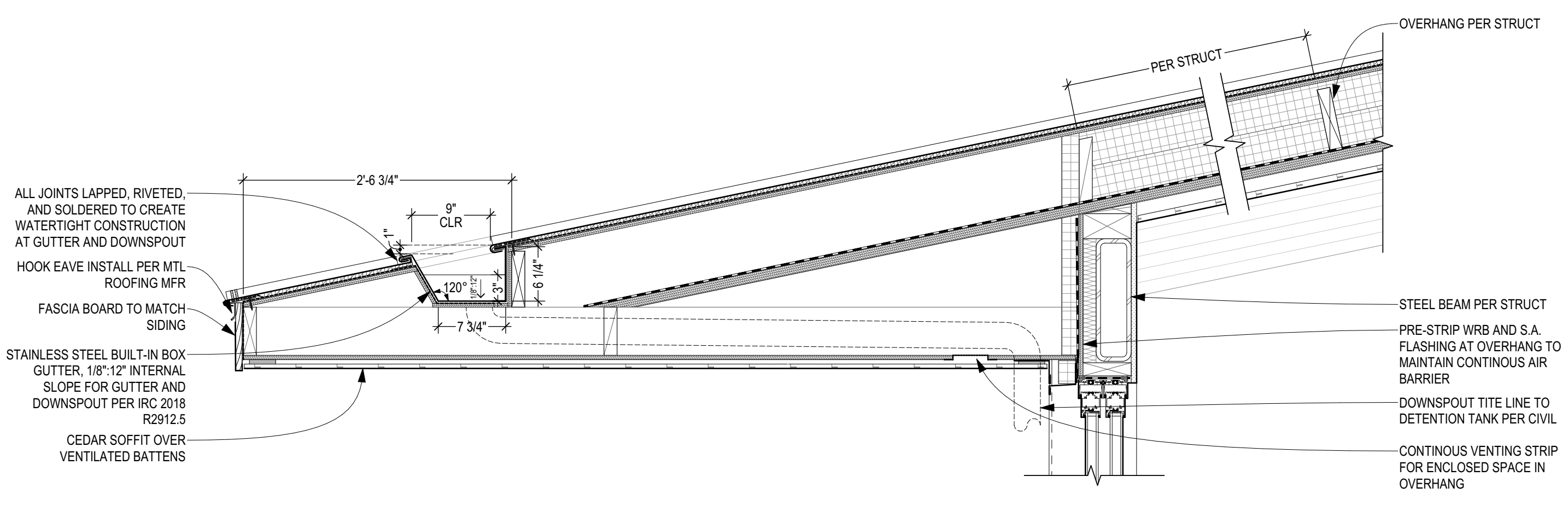

B3 TYP. OVERHANG
SCALE: 1" = 1'-0"

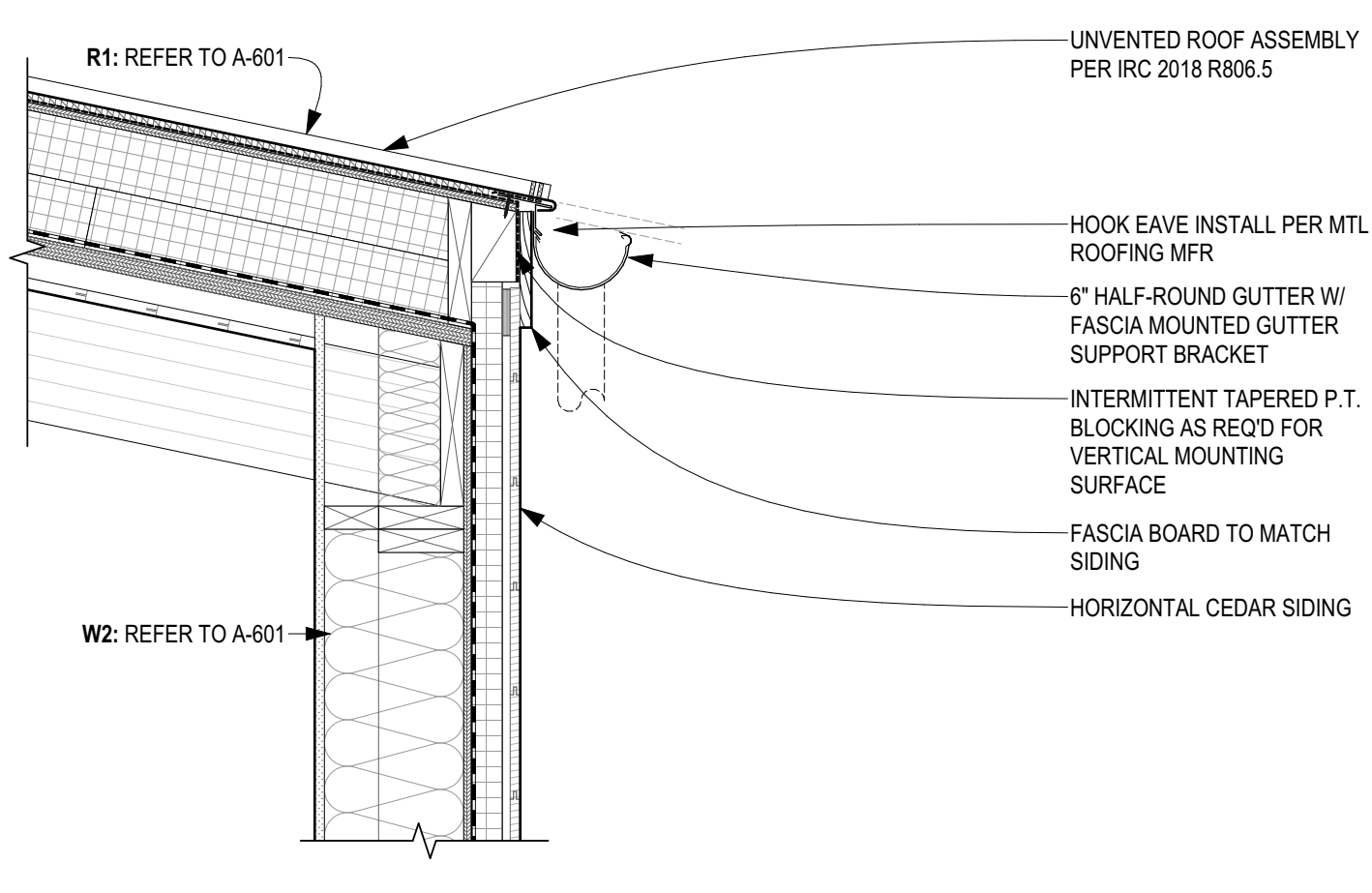

A3 TYP. GUTTER
SCALE: 1" = 1'-0"

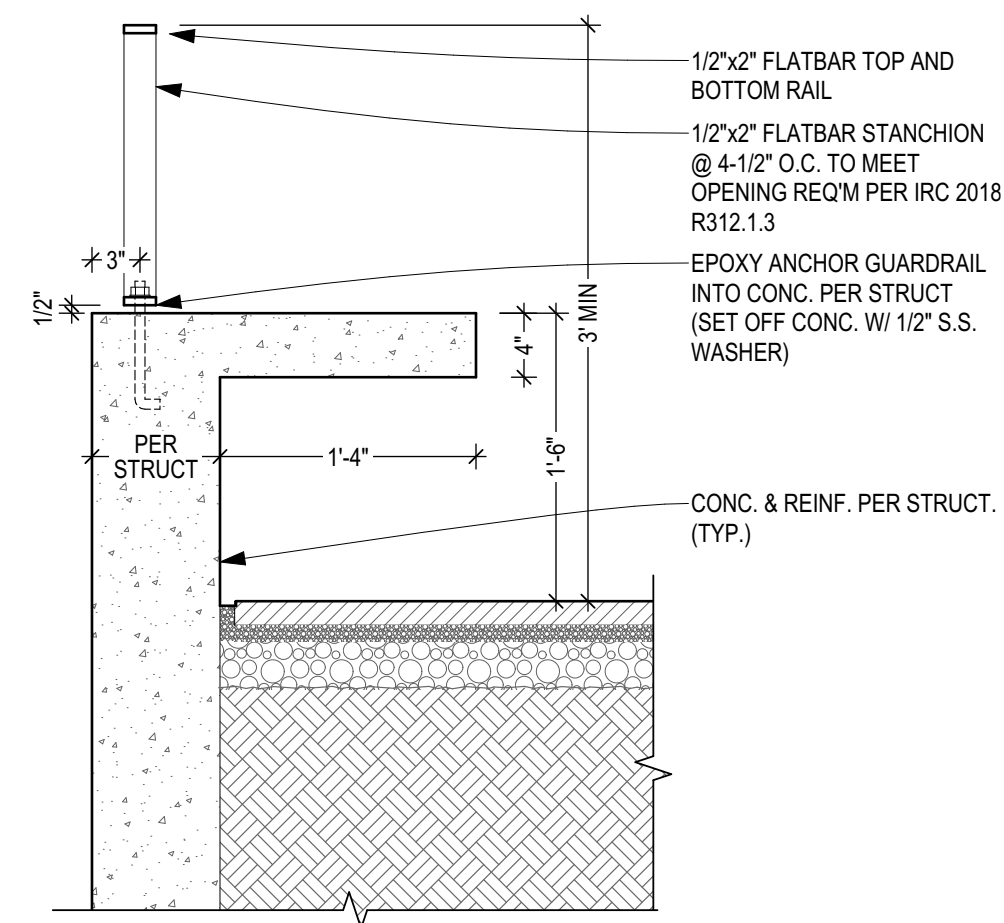

D2 UPPER PATIO CONC WALL & BENCH
SCALE: 1" = 1'-0"

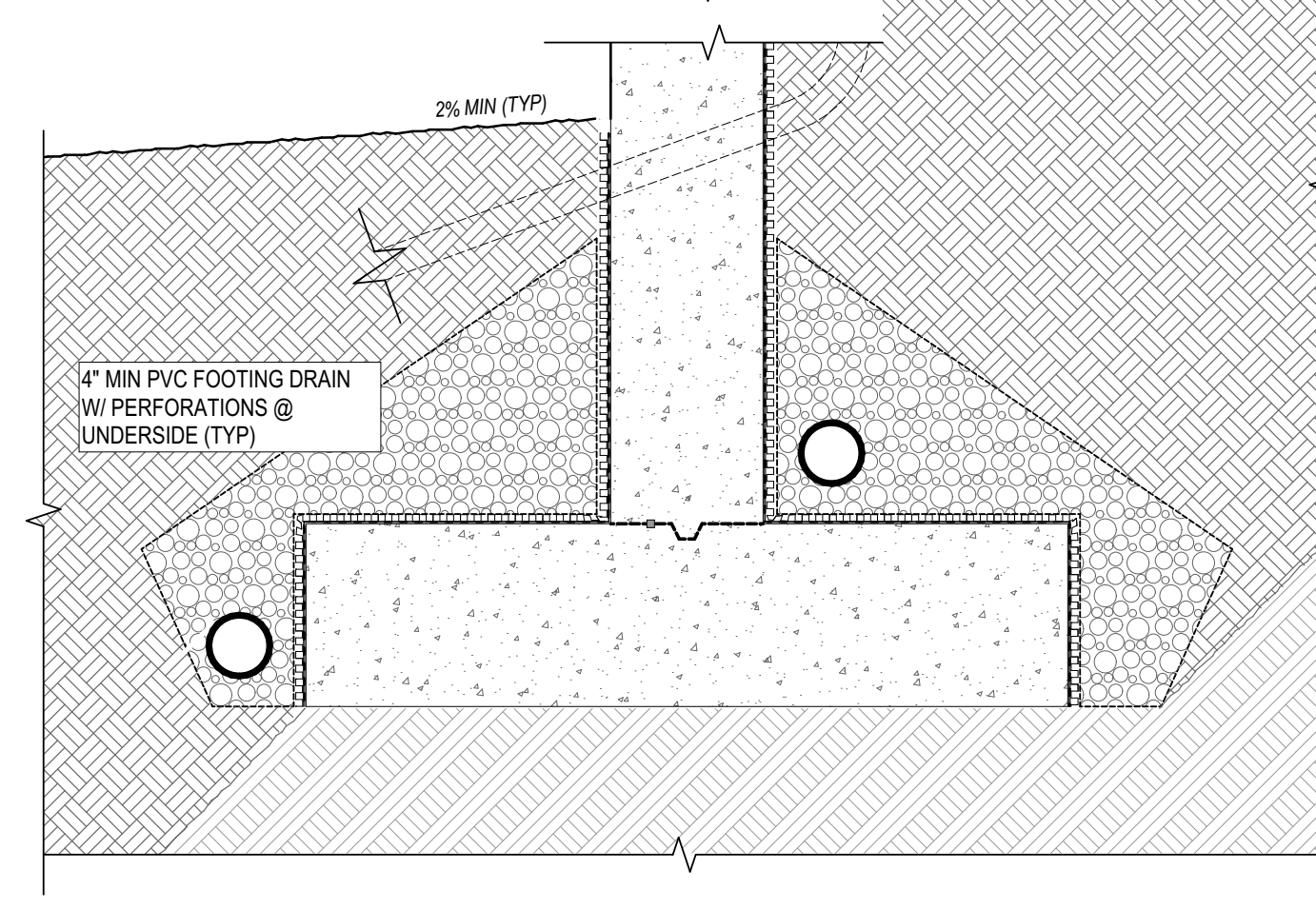
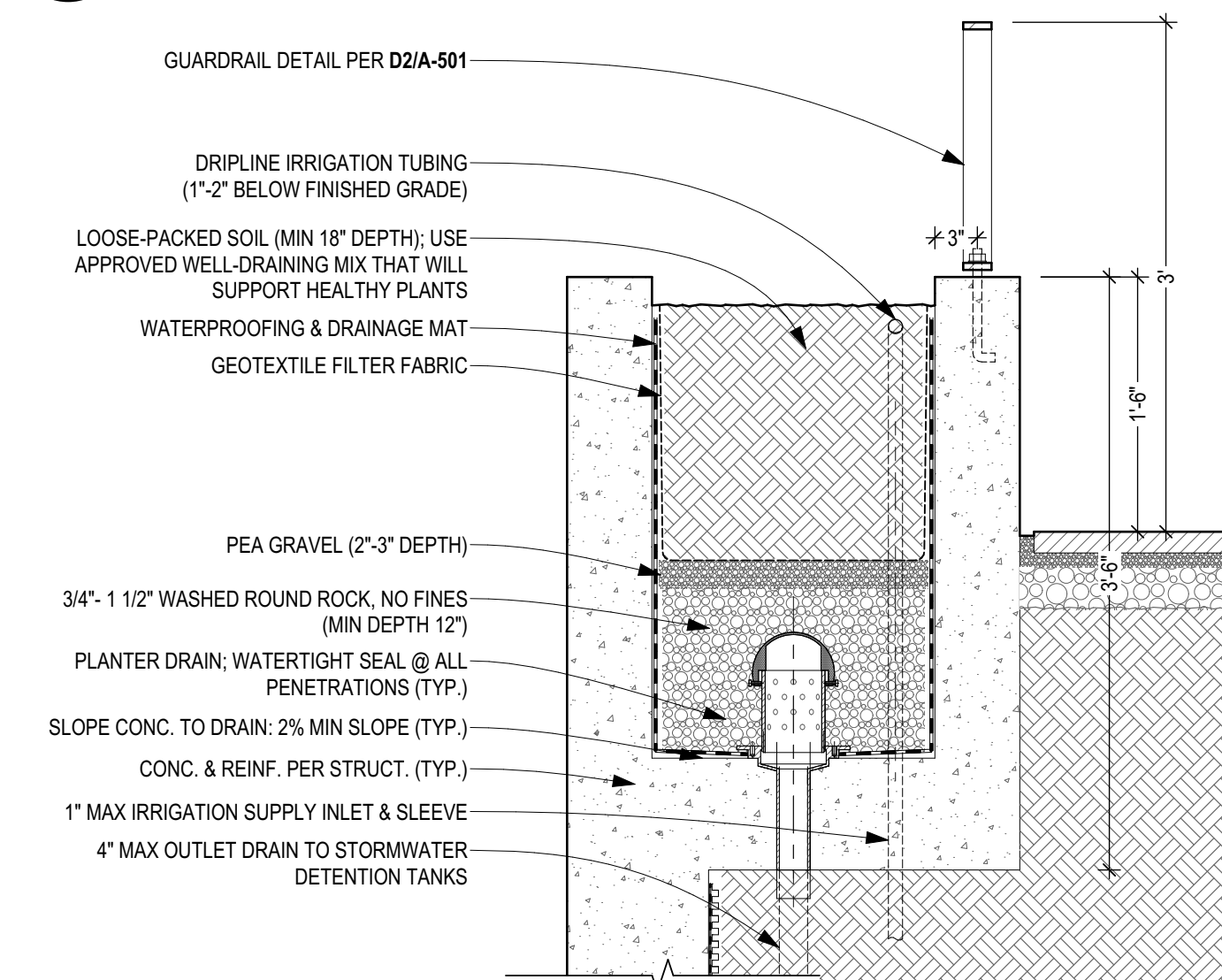

C1 UPPER PATIO PLANTER
SCALE: 1" = 1'-0"

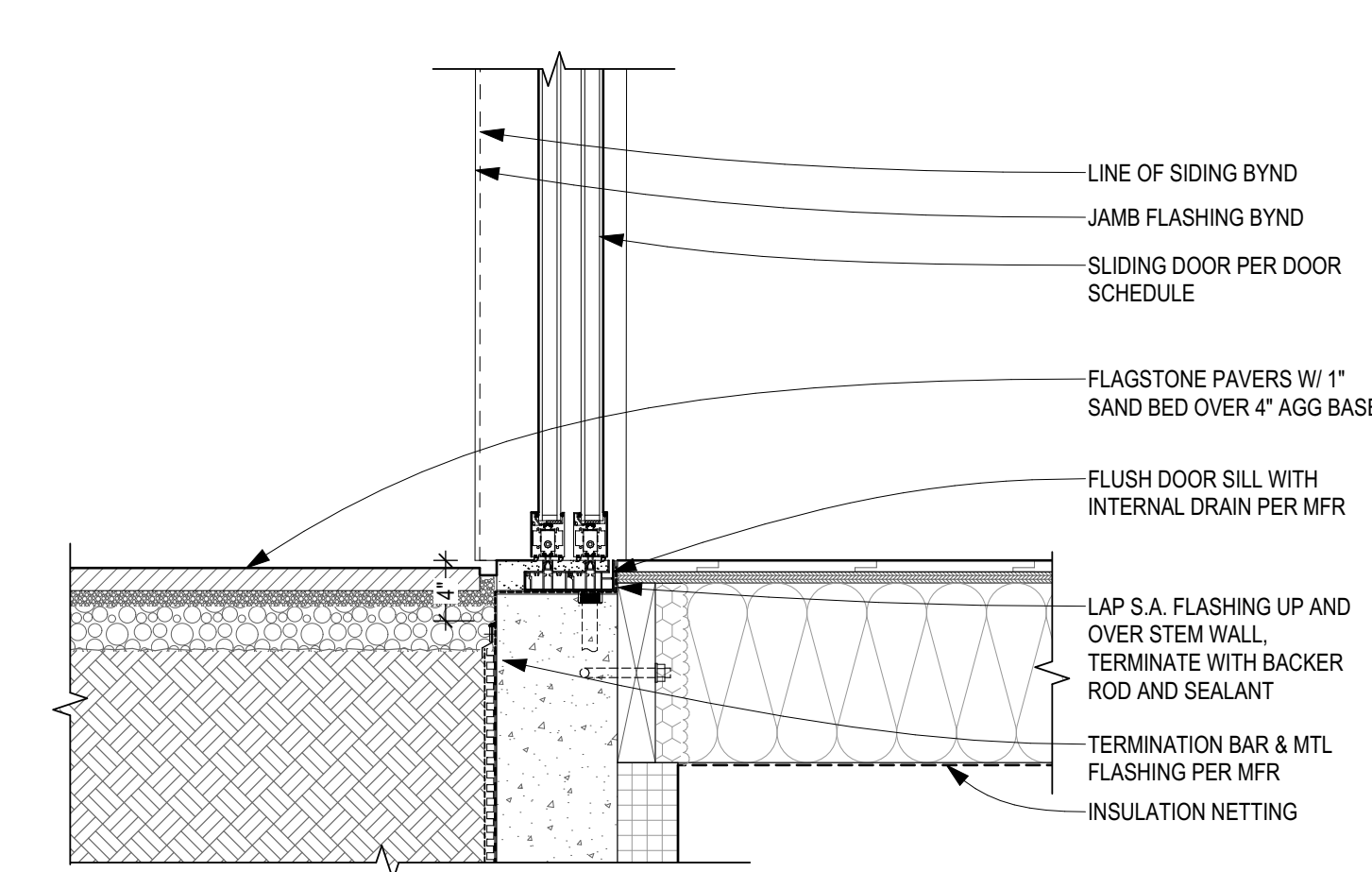

B2 SLIDING DOOR SILL AT PATIO
SCALE: 1" = 1'-0"

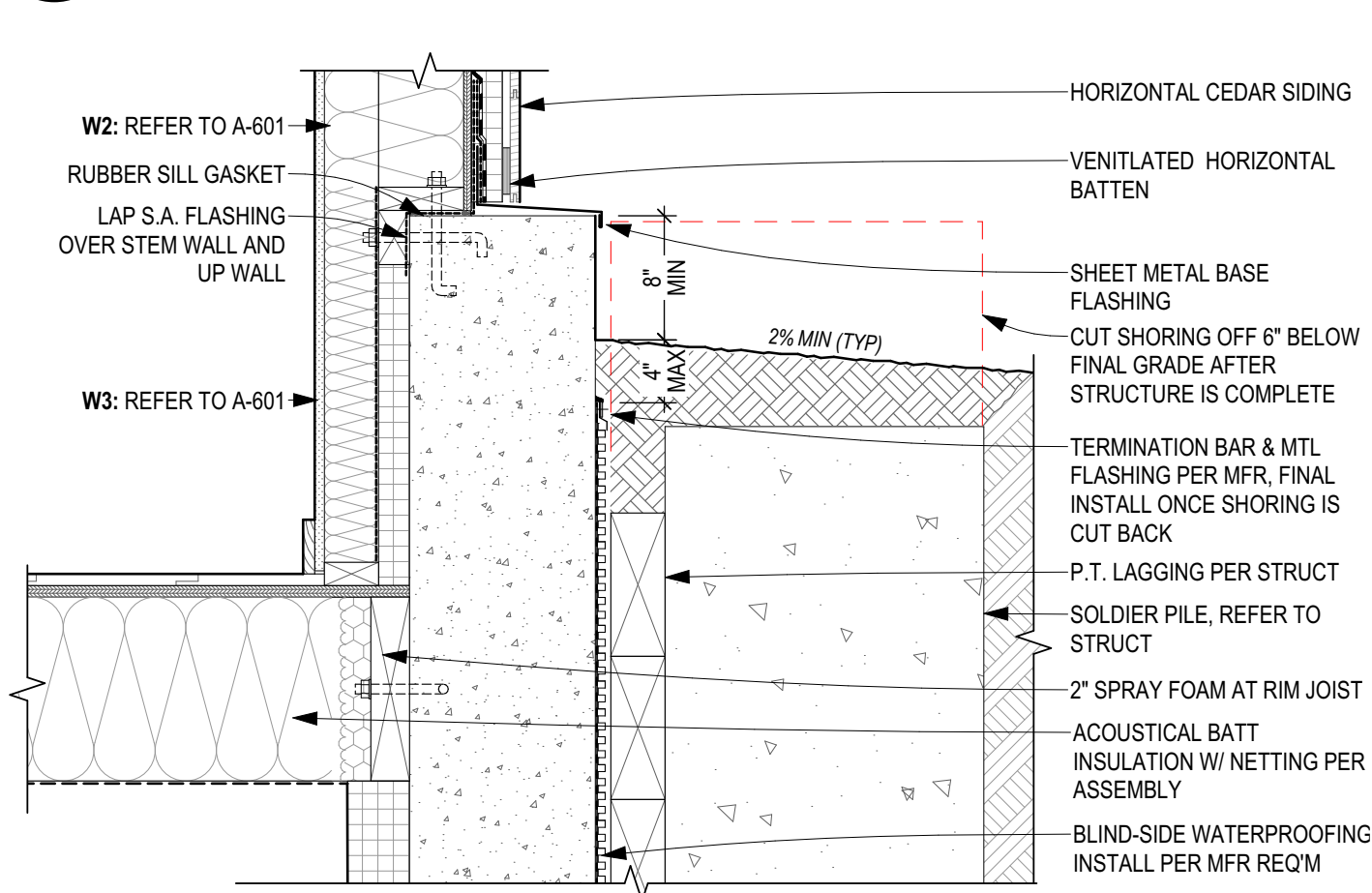

A2 TYP. WALL BASE AT SHORING
SCALE: 1" = 1'-0"

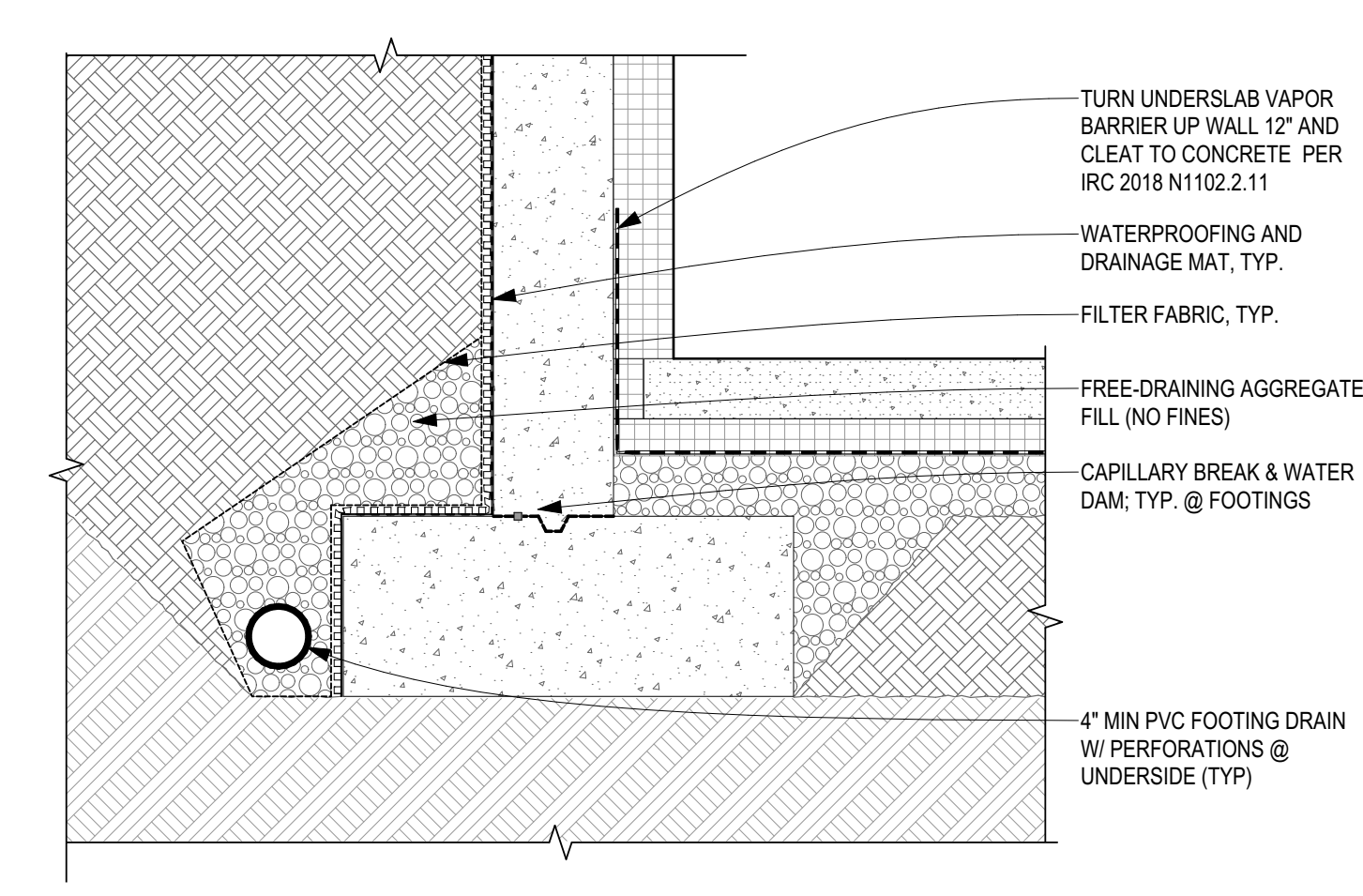

B1 TYP. FOOTING
SCALE: 1" = 1'-0"

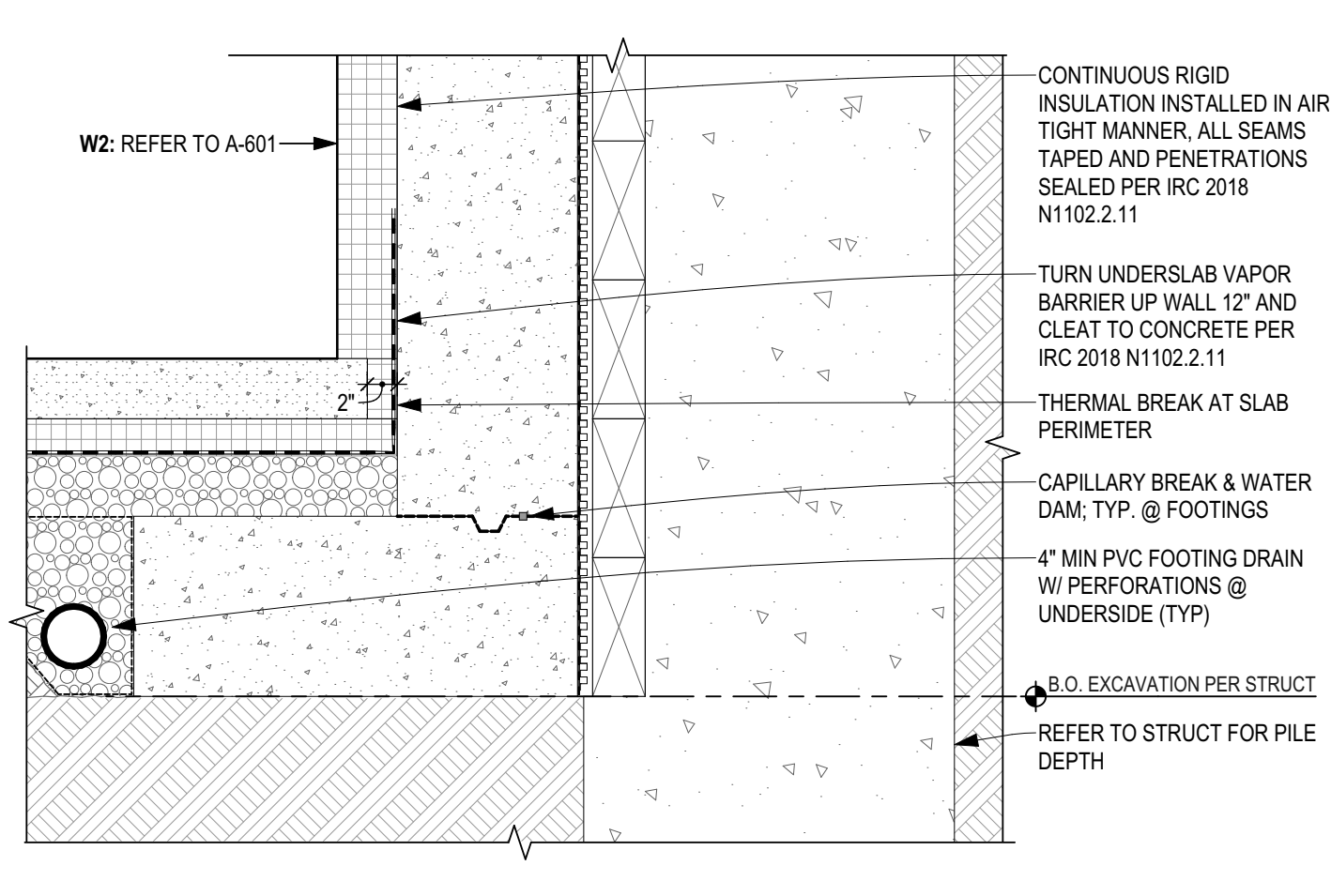

A1 TYP. FOOTING AT SHORING
SCALE: 1" = 1'-0"



CONTACT
SHED ARCHITECTURE & DESIGN
1401 S JACKSON ST
SEATTLE, WA 98144
206.320.8700

PROJECT
SULLIVAN
3024 69th Ave SE
MERCER ISLAND, WA 98040

ISSUE	DATE
PRE APP #1 (PRE22-0433)	2022.08.16
CAR 2 (CAO22-023)	2022.12.08
PERMIT SET	2023.01.20
REVISION #1	2023.05.26
REVISION #2	2023.07.07

DRAWING TITLE
EXTERIOR DETAILS

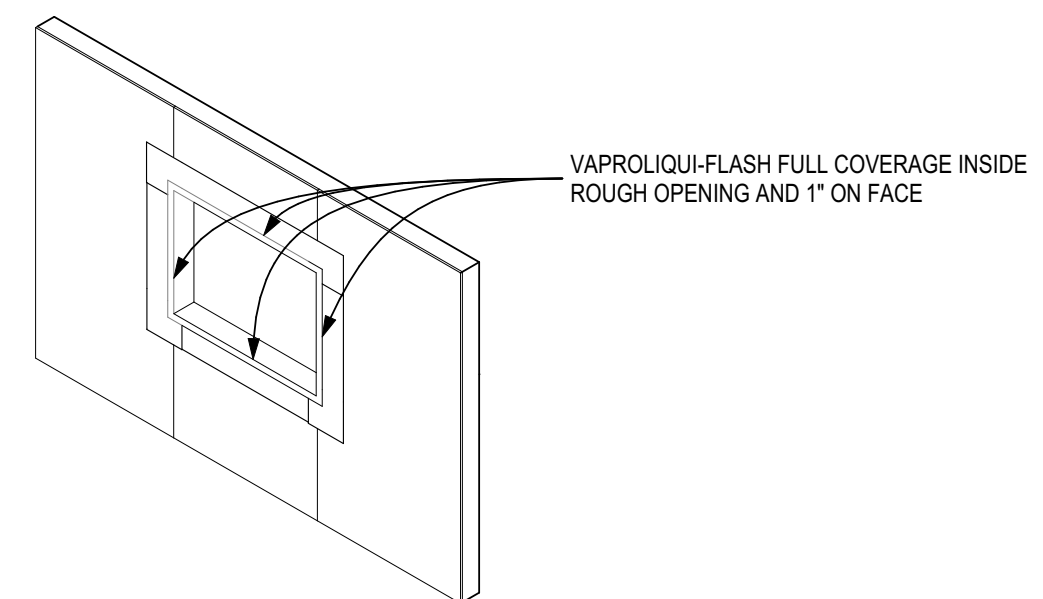
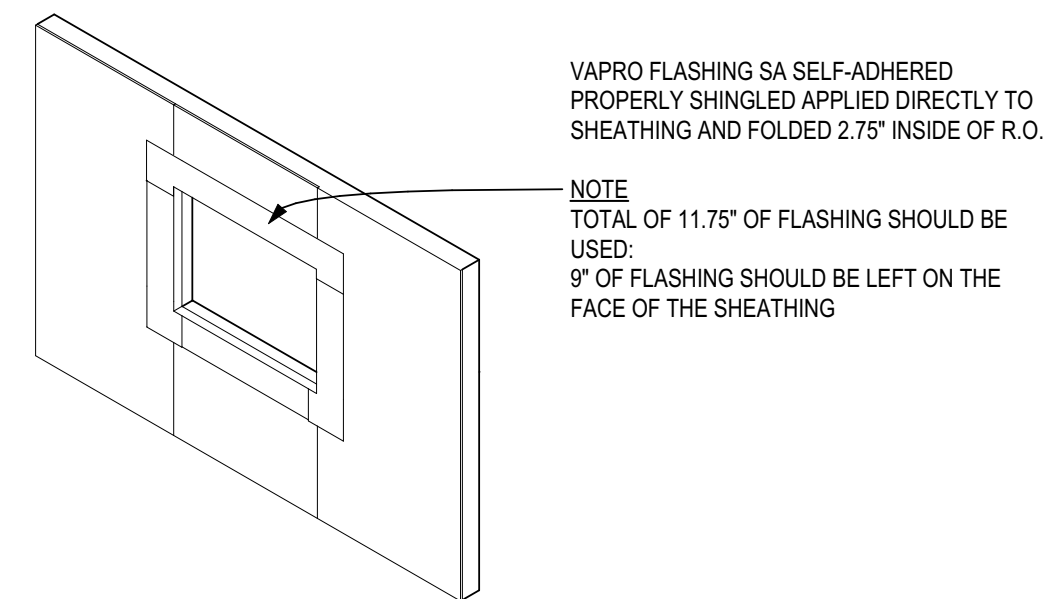
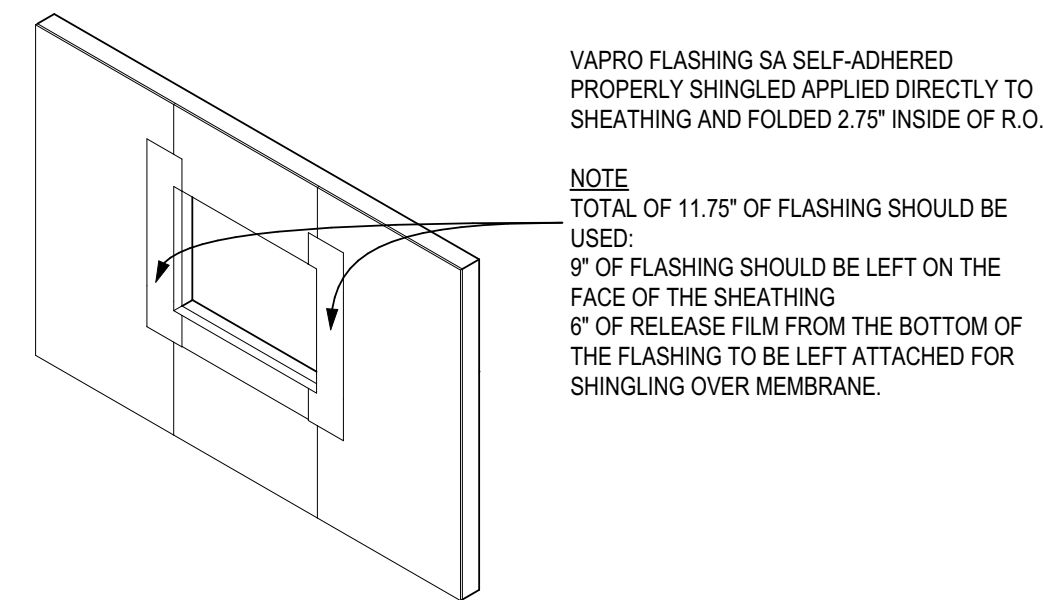
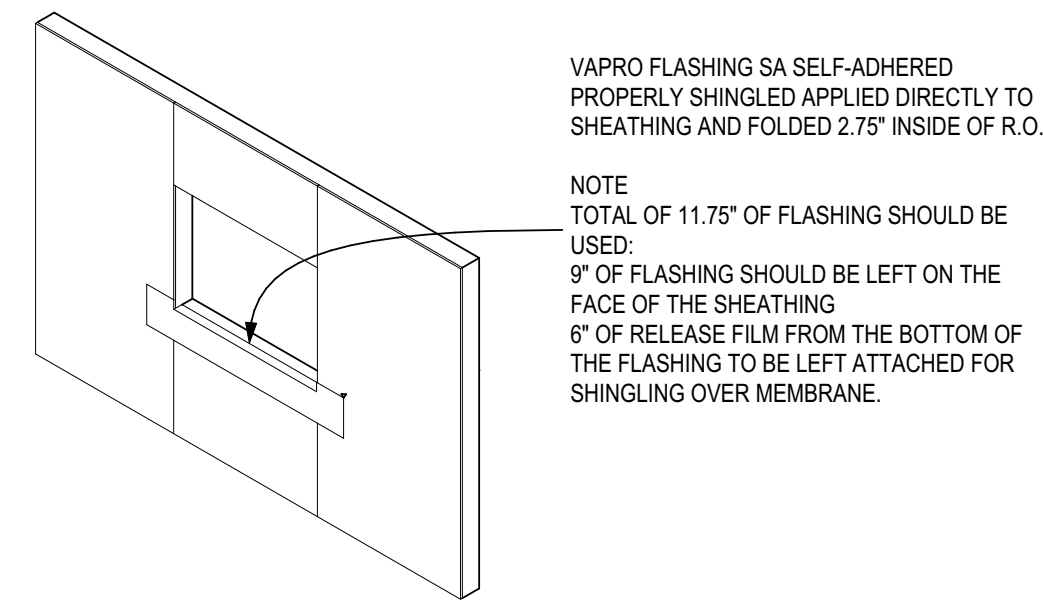
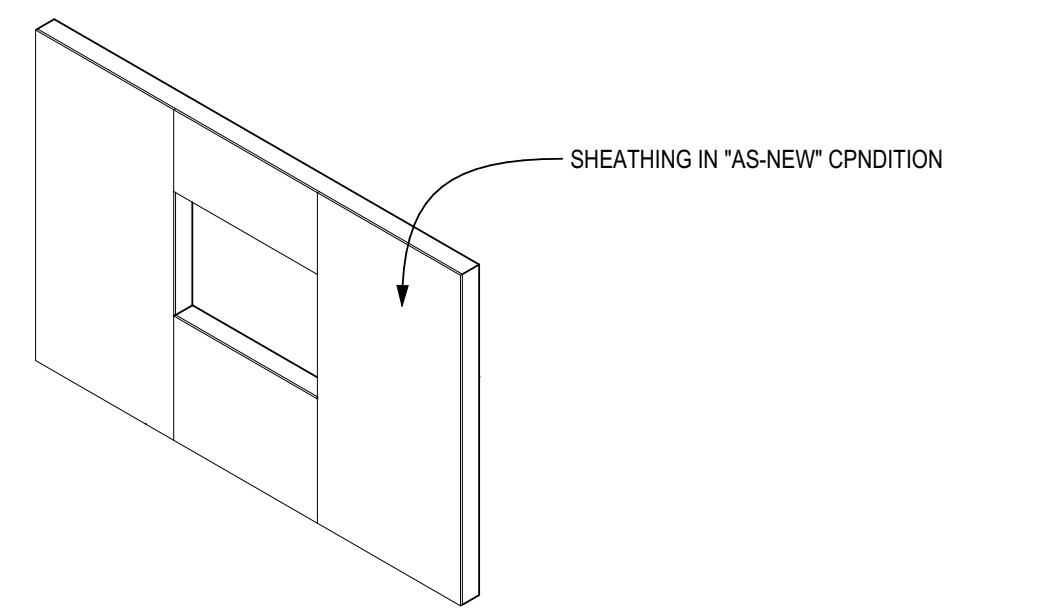

D2 TYP. ROUGH OPENING PREP
NOT TO SCALE

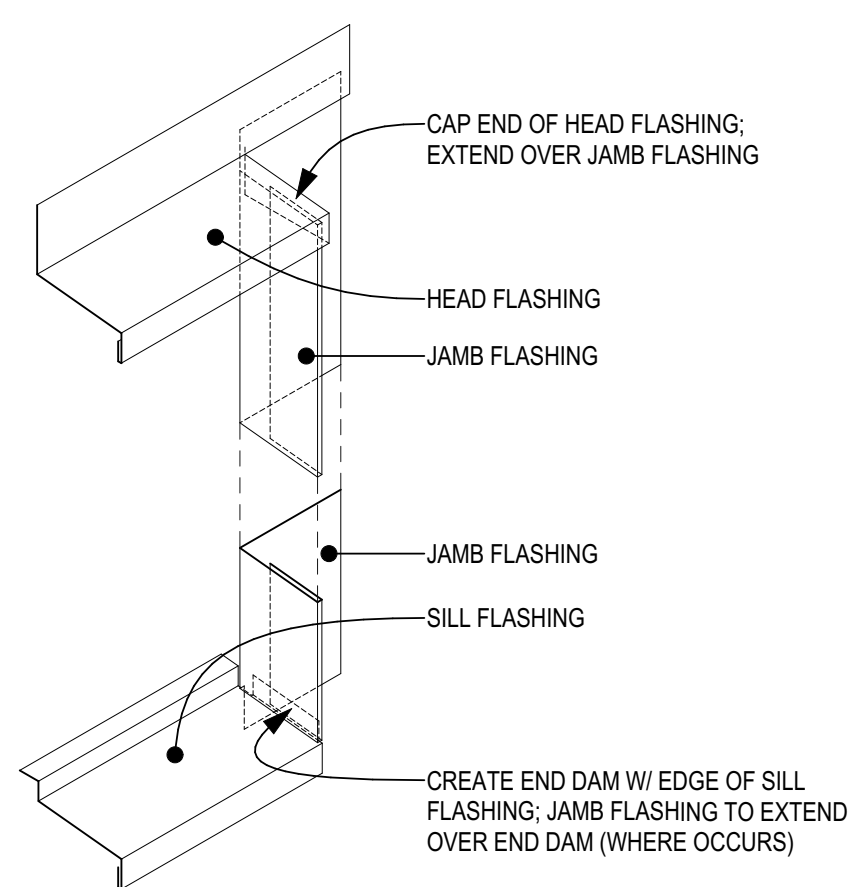

D1 TYP. MTL FLASHING ASSEMBLY
NOT TO SCALE

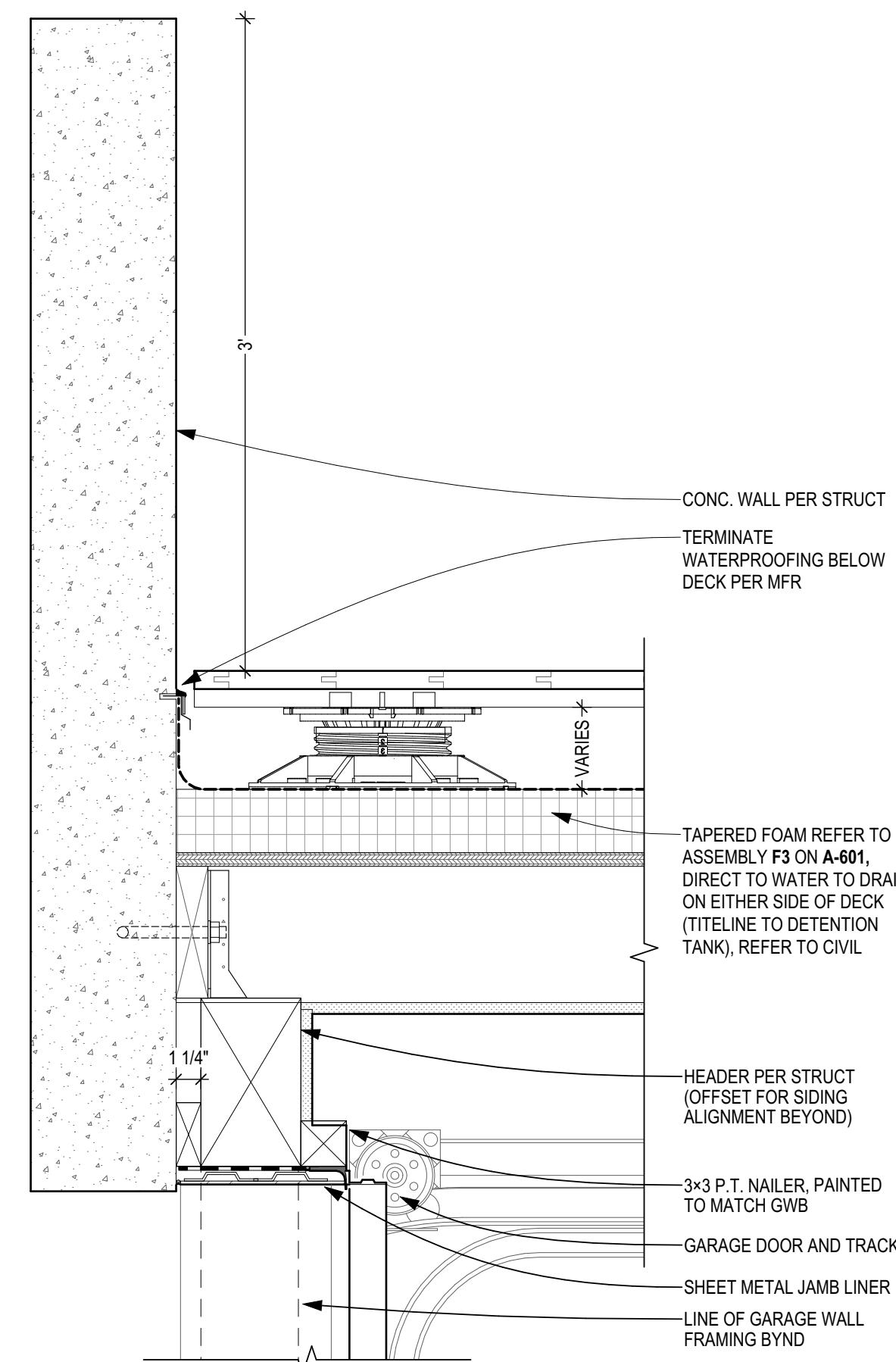

C1 GUEST PORCH AT CONC WALL
SCALE: 1 1/2" = 1'-0"

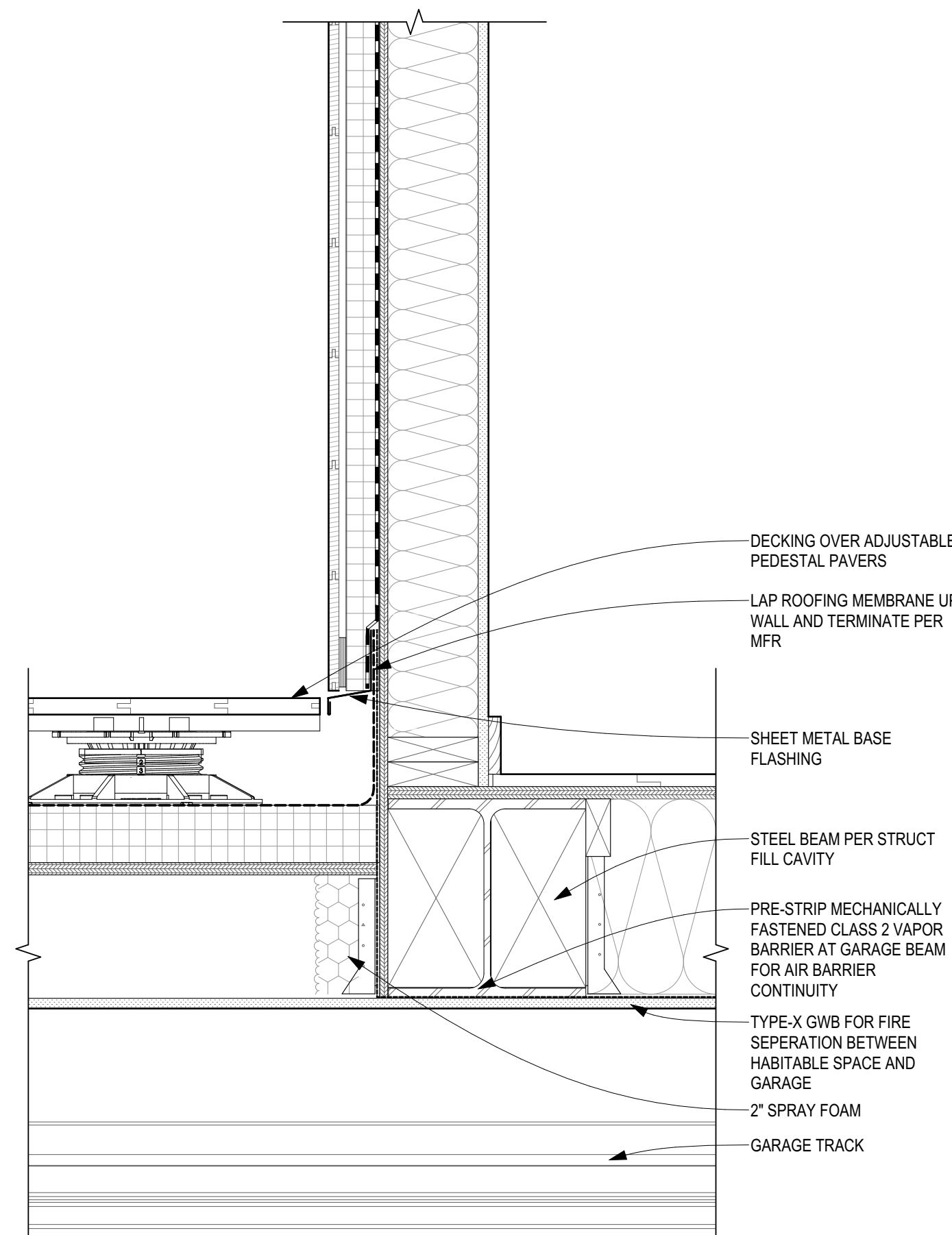

B1 GUEST PORCH AT FRAMED WALL
SCALE: 1 1/2" = 1'-0"

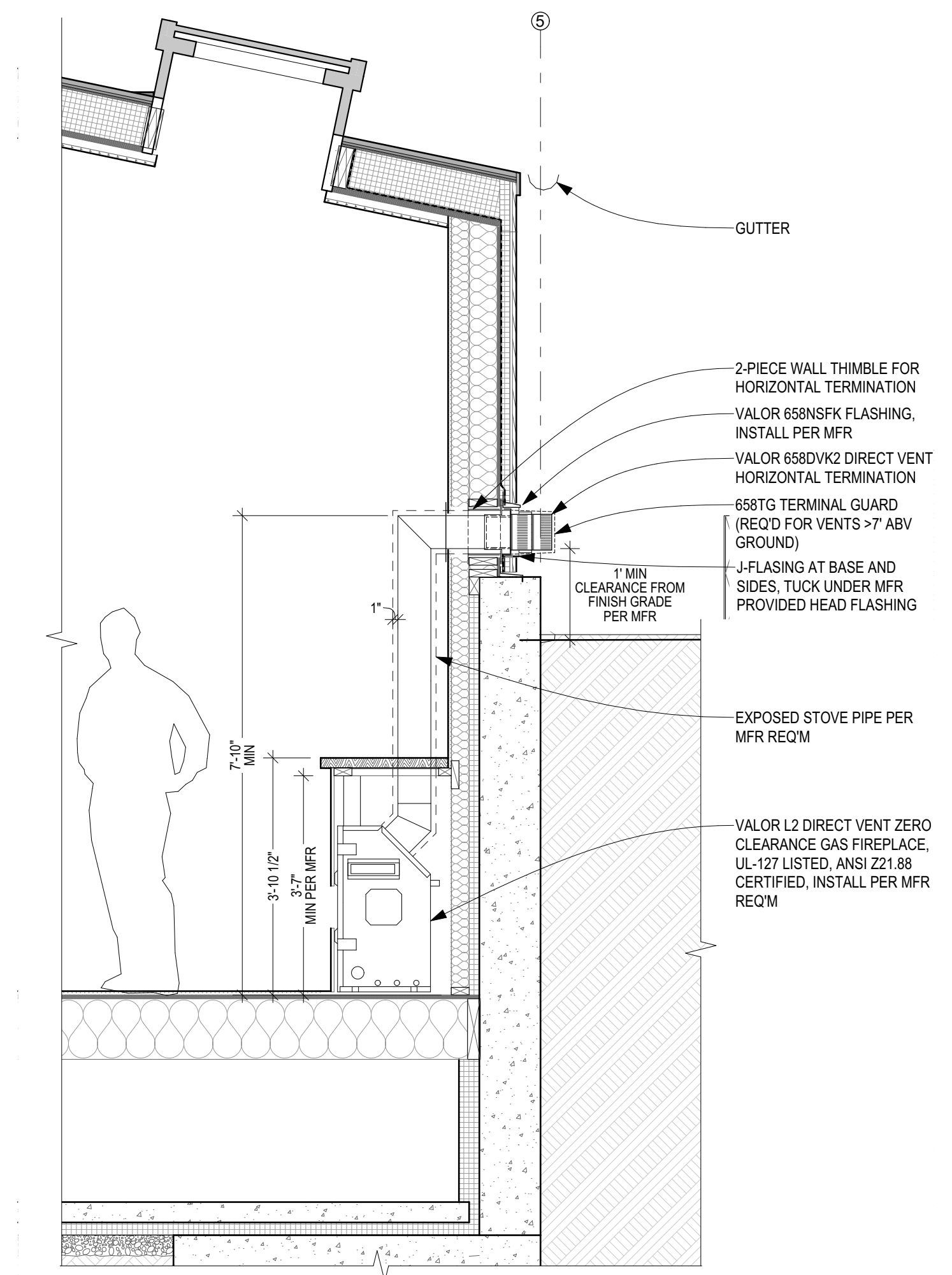

A3 SECTION THROUGH FIREPLACE
SCALE: 1/2" = 1'-0"

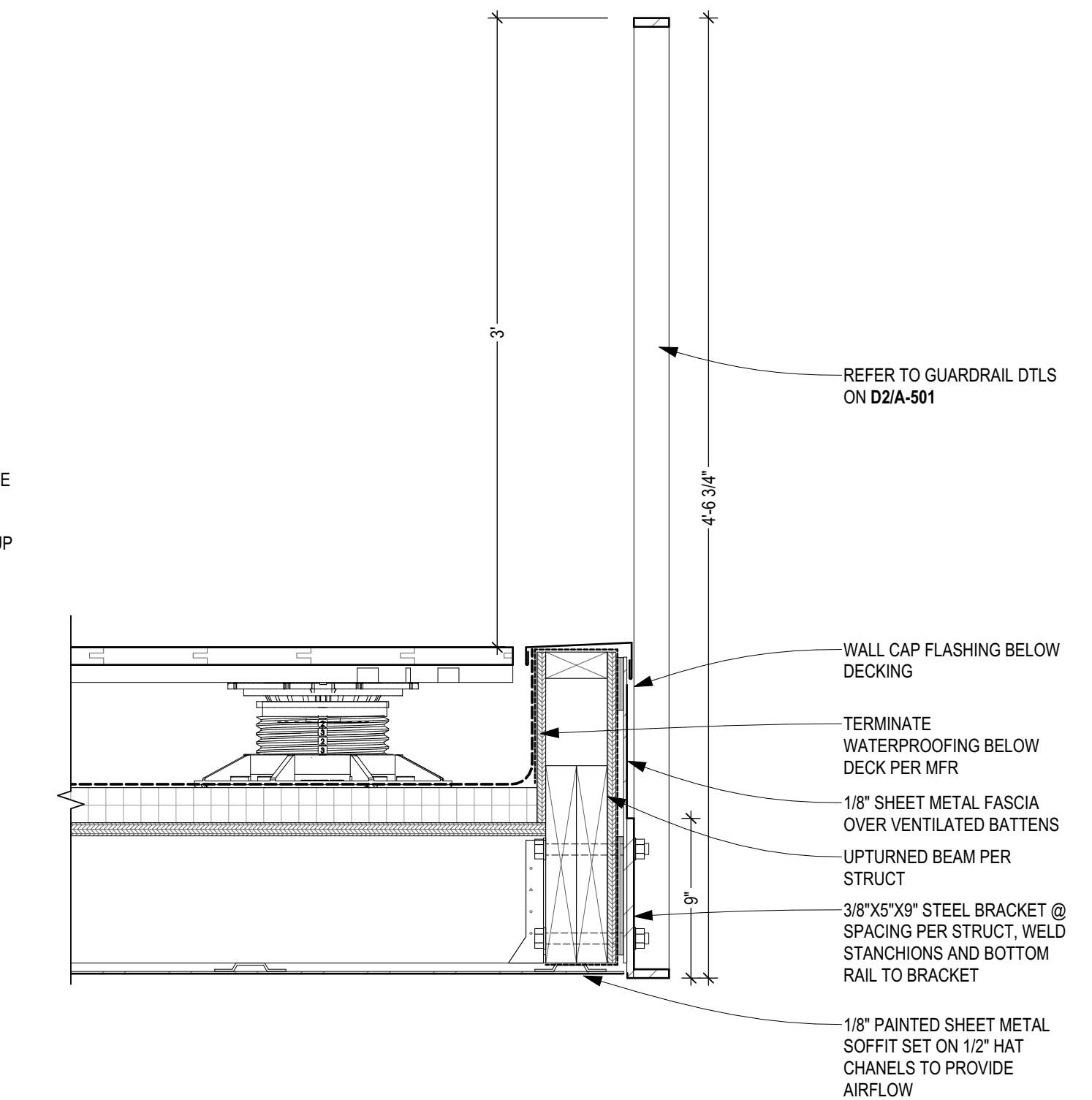

A1 GUEST PORCH GUARD RAIL
SCALE: 1 1/2" = 1'-0"



CONTACT
SHED ARCHITECTURE & DESIGN
1401 S JACKSON ST
SEATTLE, WA 98144
206.320.8700

PROJECT
SULLIVAN
3024 69th Ave SE
MERCER ISLAND, WA 98040

ISSUE	DATE
PRE APP #1 (PRE22-0433)	2022.08.16
CAR 2 (CAO22-023)	2022.12.08
PERMIT SET	2023.01.20
REVISION #1	2023.05.26
REVISION #2	2023.07.07

DRAWING TITLE
EXTERIOR DETAILS

WALL ASSEMBLIES

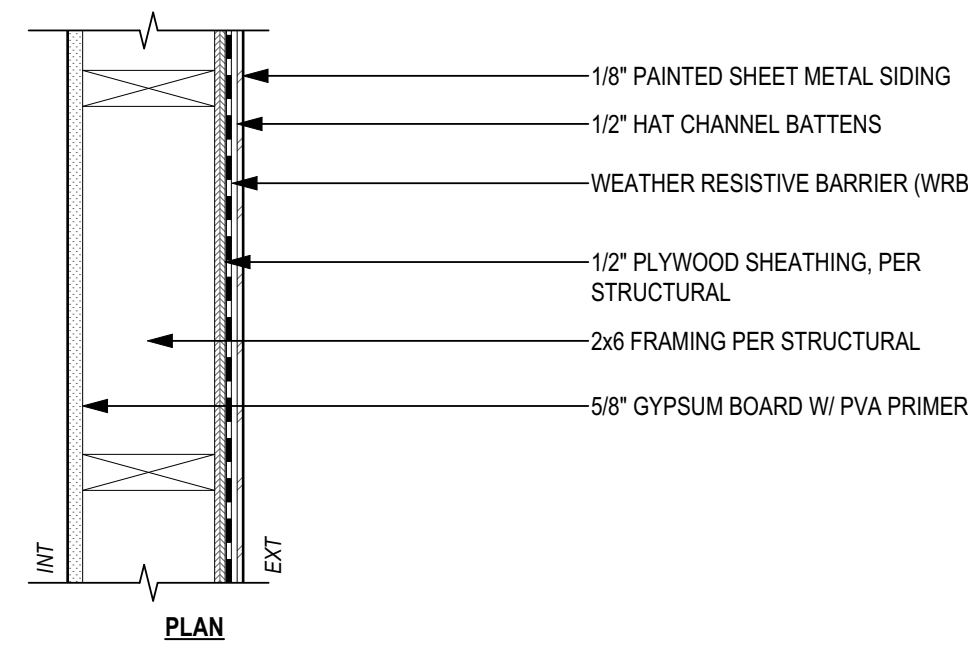

W5 EXTERIOR WALL - GARAGE WALL
N/A (CODE: N/A)

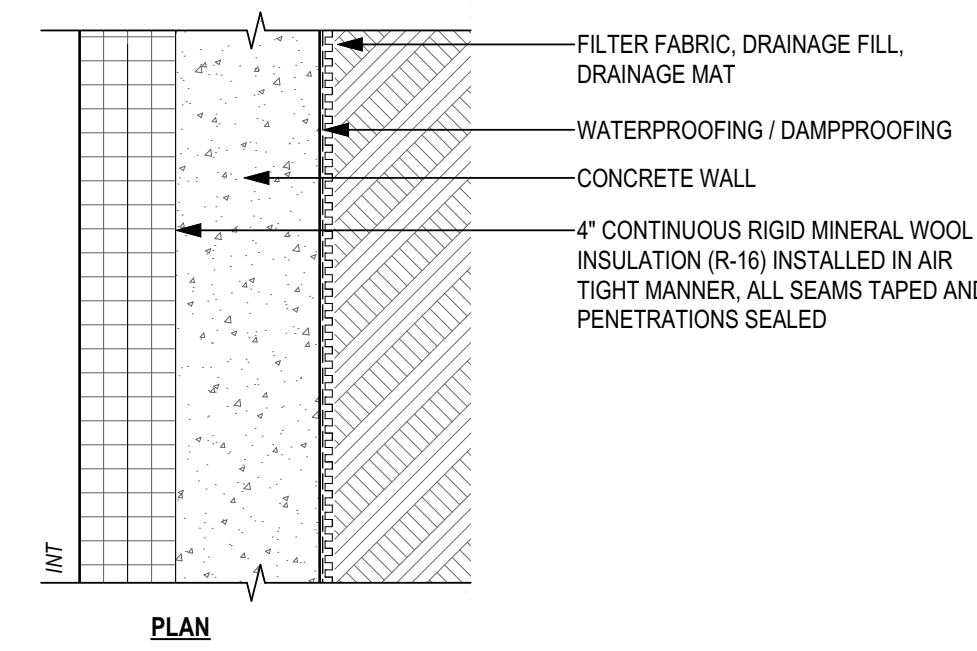

W4 EXTERIOR WALL - CRAWL SPACE
R-16 + TB* (CODE: R-10/15/21INT + TB)

*PROVIDE CONTINUOUS 2" MINERAL WOOL (R-8) THERMAL BREAK BETWEEN FLOOR SLAB AND STEM WALL

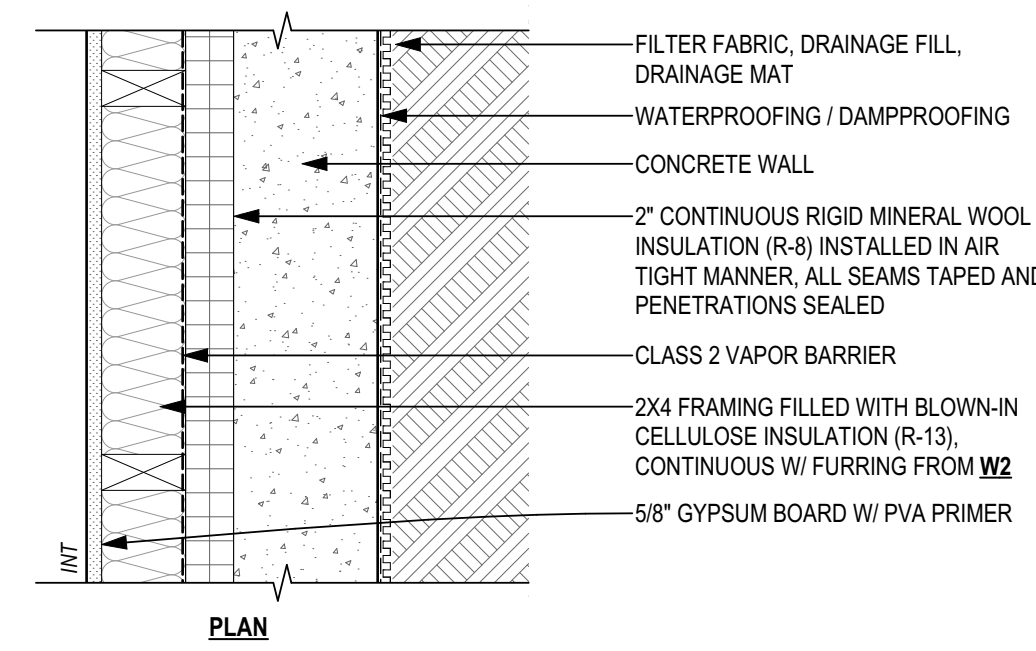

W3 EXTERIOR WALL - BELOW GRADE CODE MIN.
R-21 + TB (CODE: R-10/15/21INT + TB)

*PROVIDE CONTINUOUS 2" MINERAL WOOL (R-8) THERMAL BREAK BETWEEN FLOOR SLAB AND STEM WALL

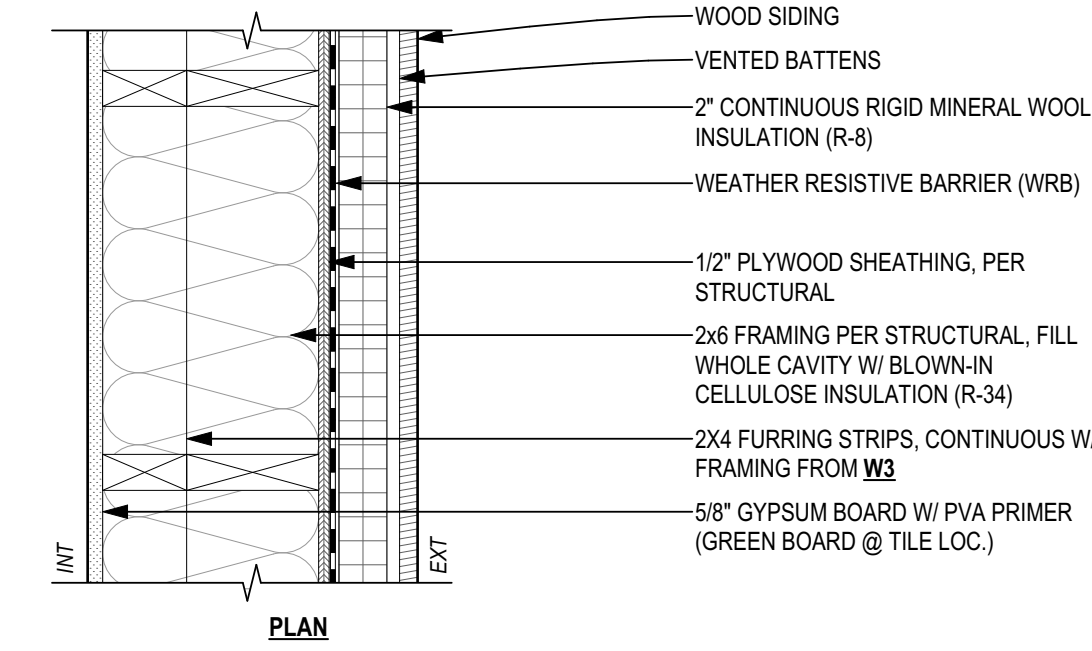

W2 EXTERIOR WALL - 2" CONTINUOUS INSULATION
R-36 (CODE: R-21)

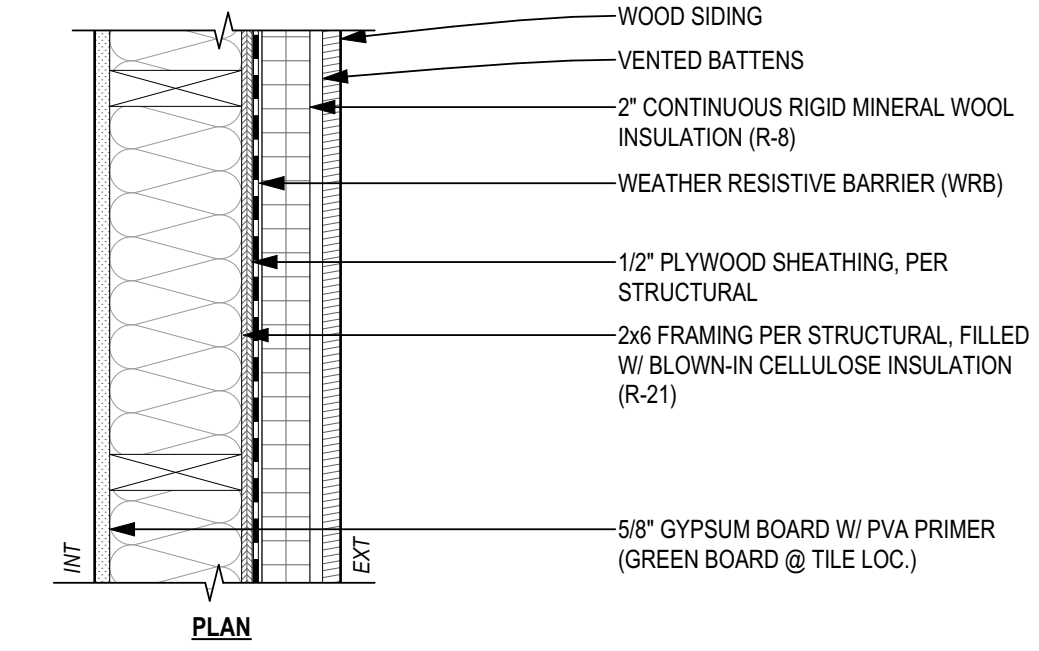

W1 EXTERIOR WALL - 2" CONTINUOUS INSULATION
R-25 (CODE: R-21)

FLOOR ASSEMBLIES

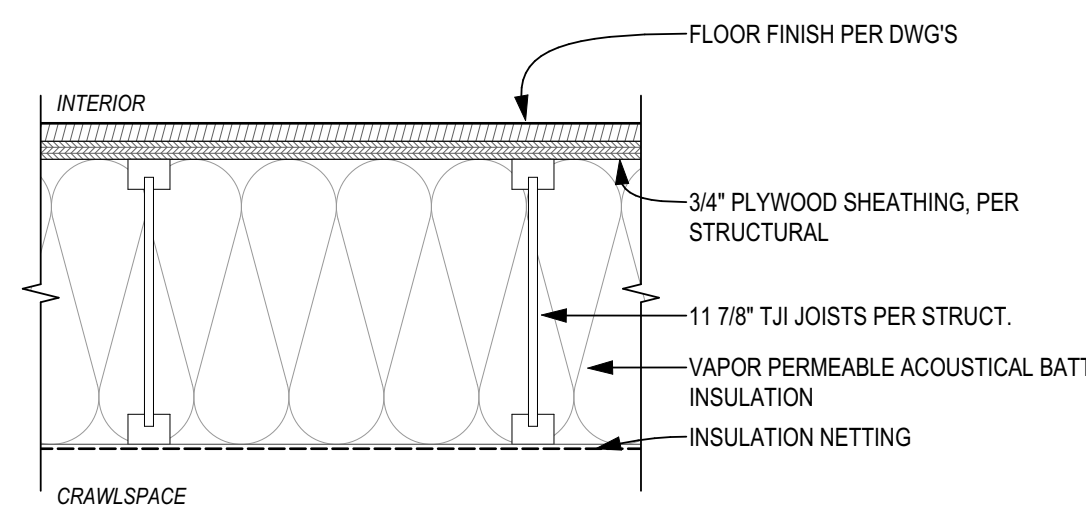

F5 CONDITIONED CRAWL SPACE

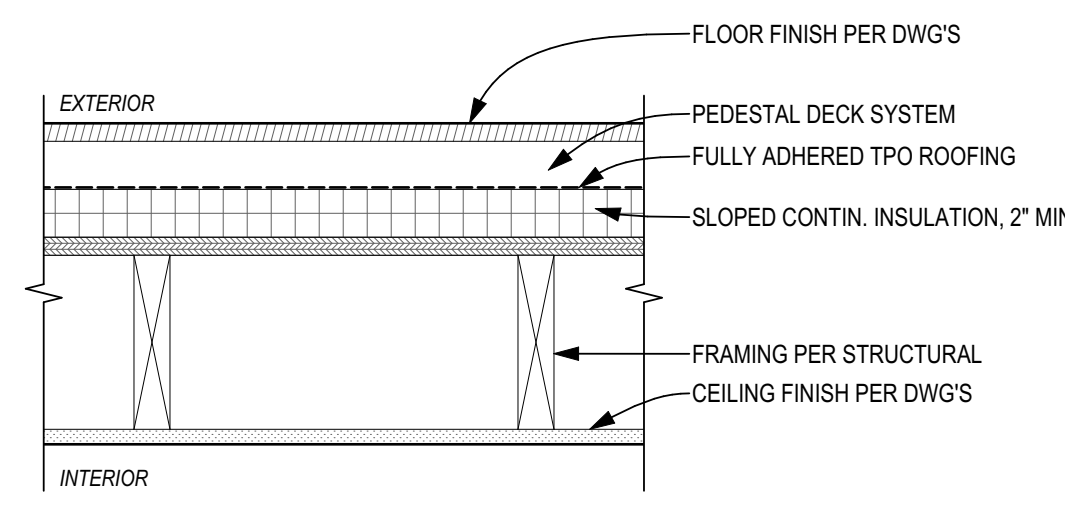

F4 GUEST PORCH

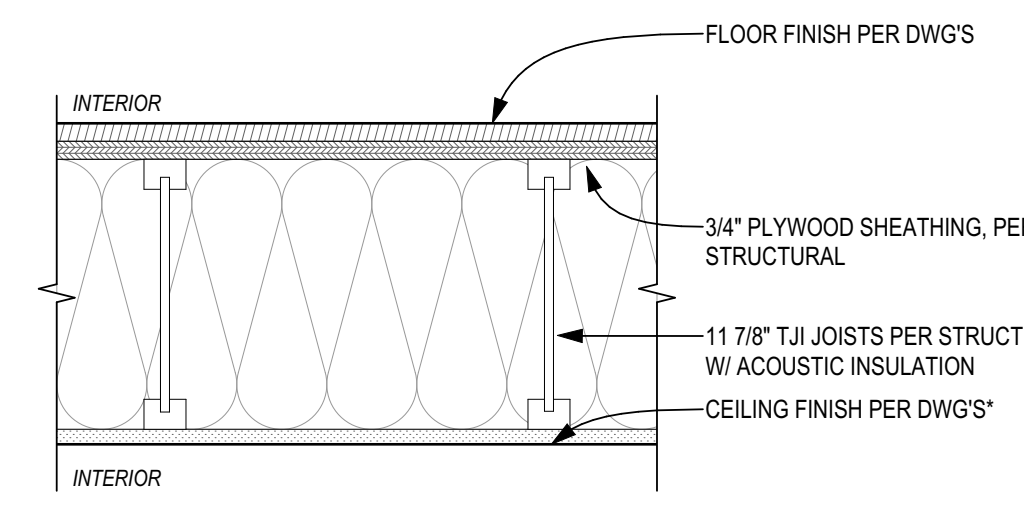

F3 TYPICAL FLOOR

*PROVIDE 5/8" TYPE-X GWB FOR 1-HR FIRE SEPARATION BETWEEN GARAGE AND INTERIOR SPACE

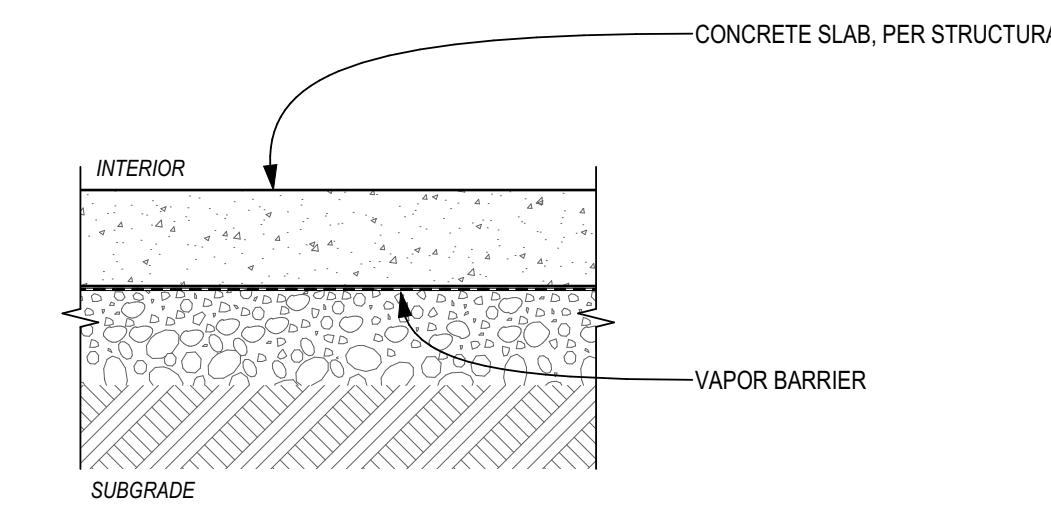

F2 SLAB ON GRADE
N/A (UNCONDITIONED SPACE)

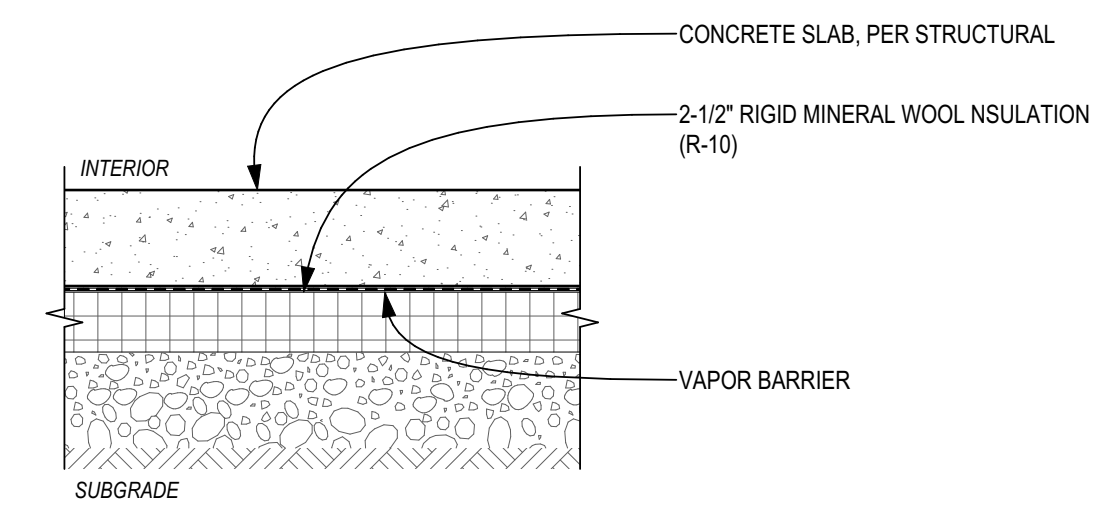

F1 INSULATED SLAB ON GRADE
R-10 (CODE: R-10)

ROOF ASSEMBLIES

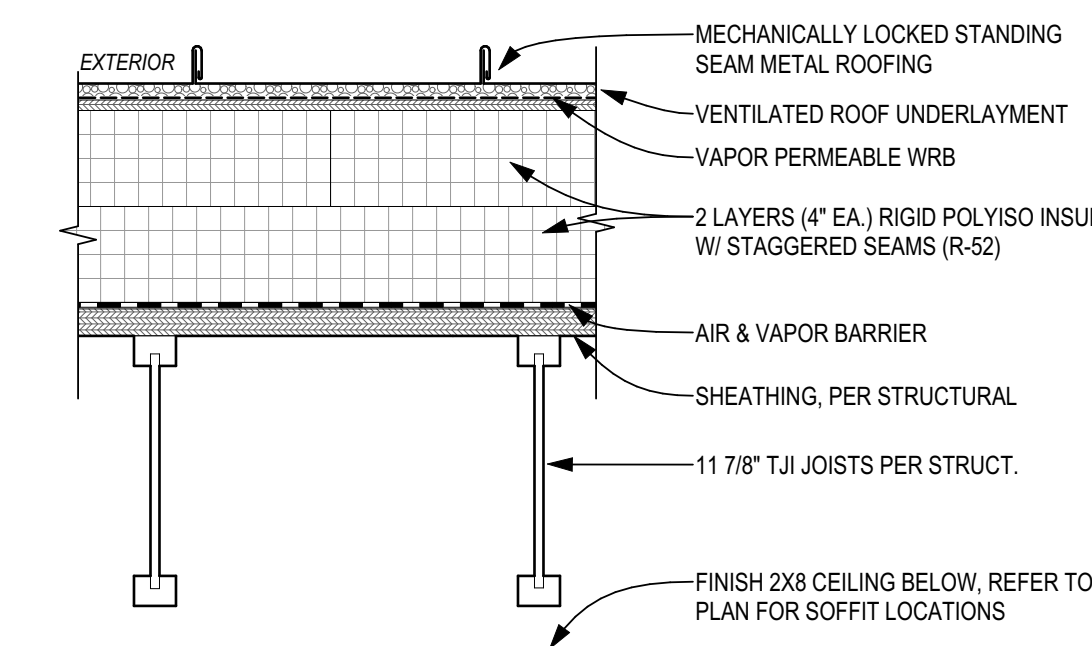

R2 ROOF, CONCEALED, UNVENTED - CONT. INSULATION
R-52 (CODE: R-38)

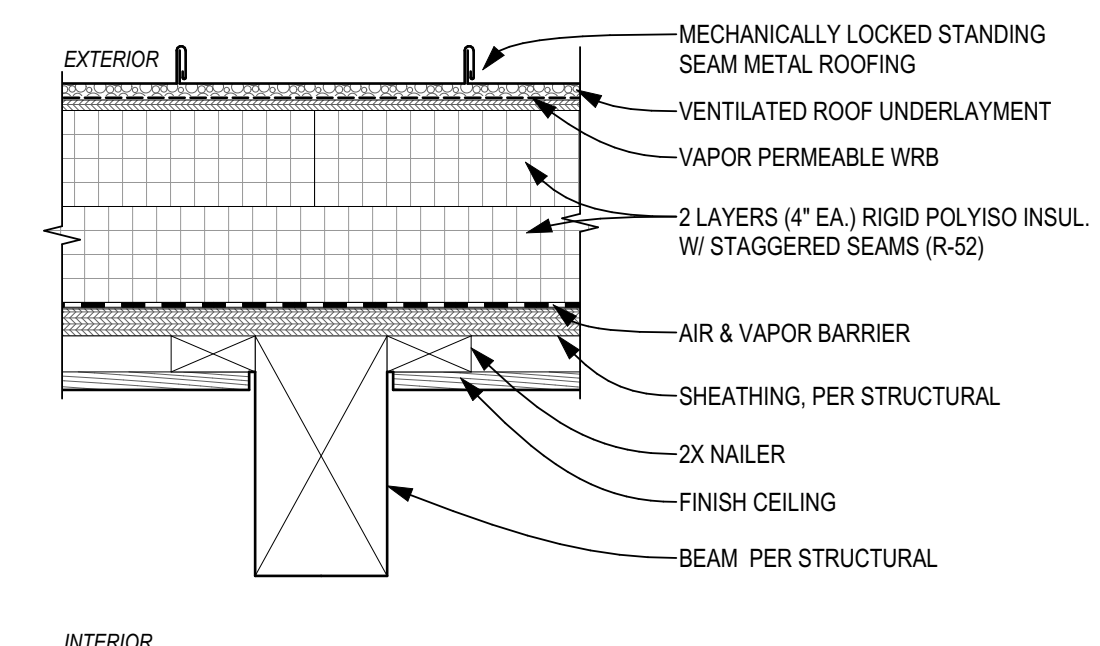

R1 ROOF, EXPOSED, UNVENTED - CONT. INSULATION
R-52 (CODE: R-38)



CONTACT
SHED ARCHITECTURE & DESIGN
1401 S JACKSON ST
SEATTLE, WA 98144
206.320.8700

PROJECT
SULLIVAN
3024 69th Ave SE
MERCER ISLAND, WA 98040

ISSUE	DATE
PRE APP #1 (PRE22-0433)	2022.08.16
CAR 2 (CAO22-023)	2022.12.08
PERMIT SET	2023.01.20
REVISION #1	2023.05.26
REVISION #2	2023.07.07

PARTITION ASSEMBLIES

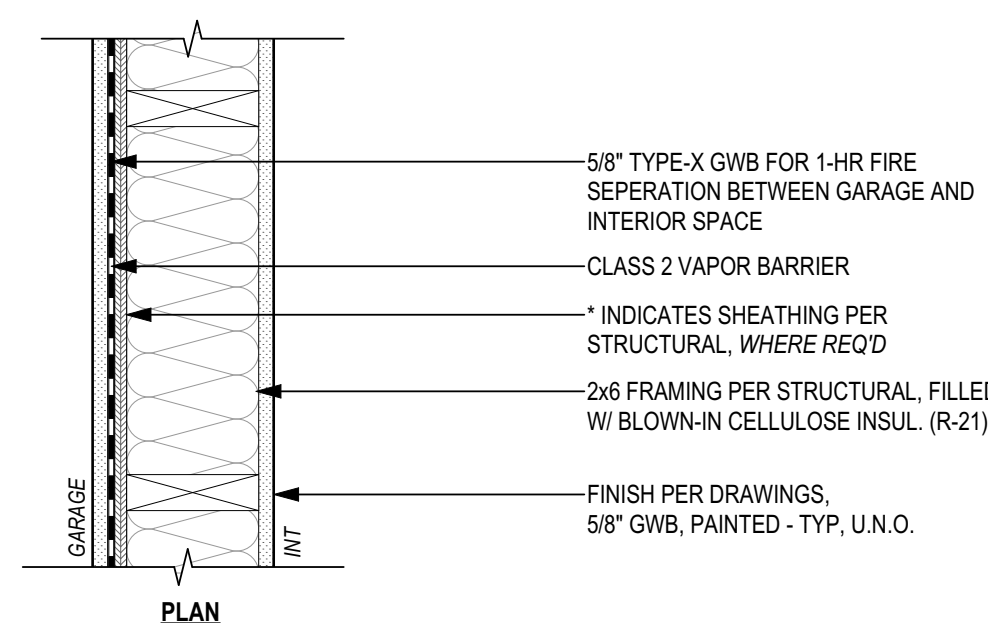

P3 GARAGE PARTITION

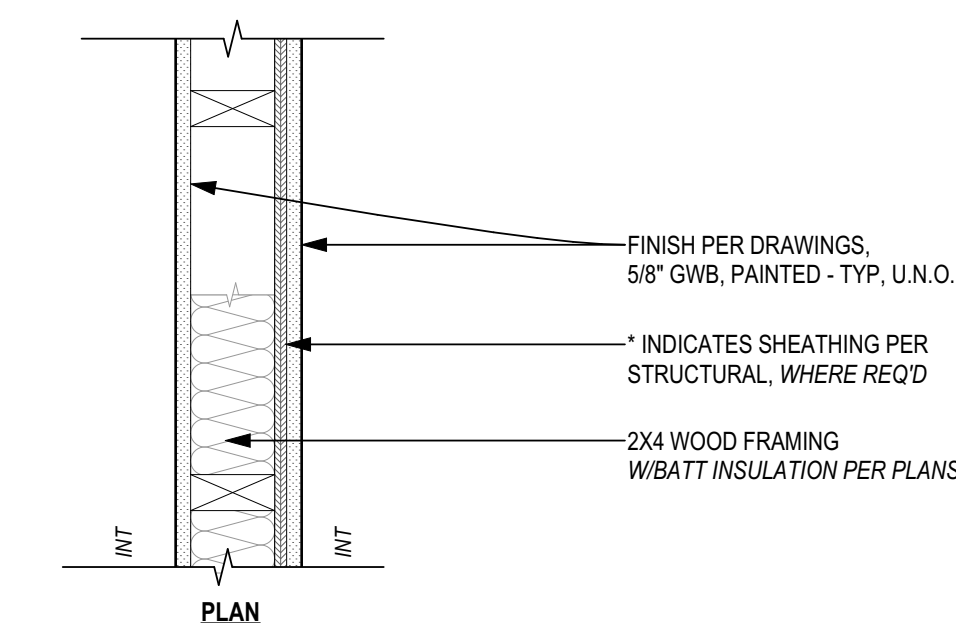

P2 TYP. 2X4 INTERIOR PARTITION

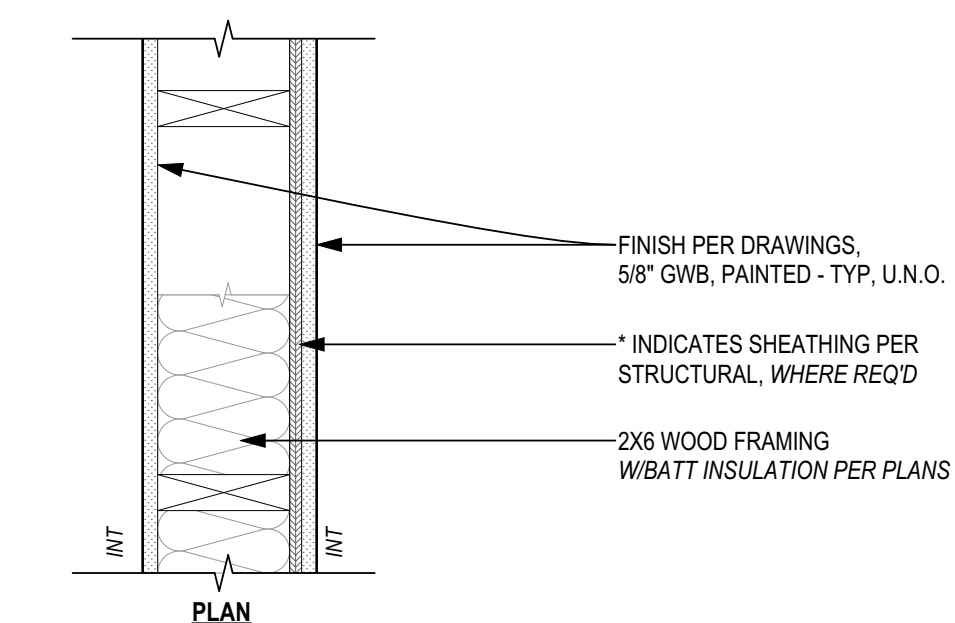

P1 TYP. 2X6 INTERIOR PARTITION

DRAWING TITLE
TYPICAL ASSEMBLIES

A-601

WINDOW & SKYLIGHT SCHEDULE

	TAG	MANUF.	MODEL	OPERATION	UNIT SIZE		SILL HEIGHT	ENERGY DATA			SCREEN	SAFETY GLAZING	EGRESS	NOTES
					WIDTH	HEIGHT		U-VALUE	SHGC	NFRC #				
LEVEL 1														
	1.1	CUSTOM		FIXED	1'-11"	7'-4 1/4"	1'-6"					<input type="checkbox"/>	S.G.	EXEMPTION PER WSEC R402.3.3 TAKEN FOR U-VALUE AND SHGC REQ'D, LESS THAN 1SSOFT
LEVEL 2														
	2.1	FLEETWOOD	450-T	FIXED	4'-0"	7'-2"	3'-10 1/2"	0.28	0.23	FLE-M-113-00079-00001	<input type="checkbox"/>			
	2.2	FLEETWOOD	450-T	FIXED	7'-0"	2'-0"	7'-14"	0.28	0.23	FLE-M-113-00079-00001	<input type="checkbox"/>			
	2.3a	FLEETWOOD	450-T	FIXED	7'-0"	2'-0"	7'-14"	0.28	0.23	FLE-M-113-00079-00001	<input type="checkbox"/>			
	2.3b	FLEETWOOD	450-T	AWNING	4'-1/2"	2'-0"	7'-14"	0.28	0.23	FLE-M-112-00113-00001	<input type="checkbox"/>			
	2.4	FLEETWOOD	450-T	CSMT. OUT	4'-0"	5'-4"	3'-8 1/4"	0.28	0.24	FLE-M-111-00113-00001	<input type="checkbox"/>		E.G.	
	2.5	FLEETWOOD	450-T	CSMT. OUT	1'-11"	5'-4"	3'-8 1/4"	0.28	0.24	FLE-M-111-00113-00001	<input type="checkbox"/>			
	2.6	FLEETWOOD	450-T	CSMT. OUT	2'-10"	4'-3"	3'-1/2"	0.28	0.24	FLE-M-111-00113-00001	<input type="checkbox"/>	S.G.		
	2.7a	FLEETWOOD	450-T	CSMT. OUT	2'-0"	5'-2 3/4"	2'-3/4"	0.28	0.24	FLE-M-111-00113-00001	<input type="checkbox"/>	S.G.		
	2.7b	FLEETWOOD	450-T	FIXED	3'-2"	5'-2 3/4"	2'-3/4"	0.28	0.23	FLE-M-113-00079-00001	<input type="checkbox"/>	S.G.		
	2.8a	FLEETWOOD	450-T	CSMT. OUT	3'-4 1/2"	5'-2 3/4"	2'-3/4"	0.28	0.24	FLE-M-111-00113-00001	<input type="checkbox"/>	S.G.	E.G.	
	2.8b	FLEETWOOD	450-T	FIXED	3'-4 1/2"	5'-2 3/4"	2'-3/4"	0.28	0.23	FLE-M-113-00079-00001	<input type="checkbox"/>	S.G.		
	2.8c	FLEETWOOD	450-T	FIXED	3'-4 1/2"	5'-2 3/4"	2'-3/4"	0.28	0.23	FLE-M-113-00079-00001	<input type="checkbox"/>	S.G.		
	2.8d	FLEETWOOD	450-T	FIXED	3'-5 1/2"	5'-2 3/4"	2'-3/4"	0.28	0.23	FLE-M-113-00079-00001	<input type="checkbox"/>	S.G.		
	2.9	FLEETWOOD	450-T	CSMT. OUT	3'-4"	5'-2 3/4"	2'-3/4"	0.28	0.24	FLE-M-111-00113-00001	<input type="checkbox"/>	S.G.		
	2.10	FLEETWOOD	450-T	FIXED	7'-0"	10'-10"	0"	0.28	0.23	FLE-M-113-00079-00001	<input type="checkbox"/>	S.G.		
SKYLIGHT														
	S01	CRYSTALITE	3962	FIXED	26'-8"	3'-2"	---	0.44	0.23	CRY-M-6-00520-00001	<input type="checkbox"/>	S.G.		

DOOR SCHEDULE - EXTERIOR

	TAG	MAUNF.	TYPE/MODEL	OPERATION	UNIT SIZE		ENERGY DATA			SCREEN	SAFETY GLAZING	EGRESS	HARDWARE		ACCESSORY	NOTES
					WIDTH	HEIGHT	U-VALUE	SHGC	NFRC #				GROUP/SET	TYPE		
GARAGE																
	E0.1	TBD	FLUSH, SC	SWING	3'-0"	7'-0"					<input type="checkbox"/>					
	E0.2	TBD	GARAGE	SECTIONAL	16'-0"	7'-10"					<input type="checkbox"/>					
LEVEL 1																
	E1.1	CUSTOM	SITE-BUILT	SWING	3'-6"	8'-8"					<input type="checkbox"/>					
	E1.2	FLEETWOOD	4070-T	SLIDER	6'-4"	7'-6"	0.28	0.23	FLE-M-109-00142-00001	<input type="checkbox"/>	S.G.	E.G.				
	E1.3	FLEETWOOD	4070-T	SLIDER	6'-4"	7'-6"	0.28	0.23	FLE-M-109-00142-00001	<input type="checkbox"/>	S.G.	E.G.				
LEVEL 2																
	E2.1	FLEETWOOD	4070-T	SLIDER	24'-1"	11'-0"	0.28	0.24	FLE-M-109-00142-00001	<input type="checkbox"/>	S.G.					

DOOR SCHEDULE - INTERIOR

INTERIOR DOOR SCHEDULE																
	TAG	OPERATION	UNIT SIZE			DOOR			FRAME		HARDWARE		ACCESSORY	NOTES		
			WIDTH	HEIGHT	THICK	PANEL	MATERIAL	FINISH	MATERIAL	FINISH	GROUP/SET	TYPE				
GARAGE																
	001	SWING	3'-0"	7'-0"	1 3/8"	FLUSH, SC	PT GRADE	PT-1	PT GRADE	PT-1				20MIN SOLID CORE DOOR TO COMPLY WITH R302.5.1		
	002	SWING	2'-8"	7'-0"	1 3/8"	FLUSH, SC	PT GRADE	PT-1	PT GRADE	PT-1						
	003	SWING	2'-8"	7'-0"	1 3/8"	FLUSH, SC	PT GRADE	PT-1	PT GRADE	PT-1						
	004	SWING	3'-0"	7'-0"	1 3/8"	FLUSH, SC	PT GRADE	PT-1	PT GRADE	PT-1						
LEVEL 1																
	101	SWING	1'-10"	5'-5"	1 3/8"	FLUSH, SC	PT GRADE	PT-1	PT GRADE	PT-1						
	102	SWING	2'-8"	7'-0"	1 3/8"	FLUSH, SC	PT GRADE	PT-1	PT GRADE	PT-1						
	103	POCKET	4'-11 1/2"	7'-0"	1 3/8"	FLUSH, SC	PT GRADE	PT-1	PT GRADE	PT-1						
	104	BYPASS	7'-0"	7'-0"	1 3/8"	FLUSH, SC	PT GRADE	PT-1	PT GRADE	PT-1						
	105	SWING	2'-8"	7'-0"	1 3/8"	FLUSH, SC	PT GRADE	PT-1	PT GRADE	PT-1						
	106	BYPASS	5'-0"	7'-0"	1 3/8"	FLUSH, SC	PT GRADE	PT-1	PT GRADE	PT-1						
	107	POCKET	2'-4"	7'-0"	1 3/8"	FLUSH, SC	PT GRADE	PT-1	PT GRADE	PT-1						
	108	SWING	2'-8"	7'-0"	1 3/8"	FLUSH, SC	PT GRADE	PT-1	PT GRADE	PT-1						
	109	SWING	1'-10"	7'-0"	1 3/8"	FLUSH, SC	PT GRADE	PT-1	PT GRADE	PT-1						
LEVEL 2																
	201	POCKET	2'-8"	7'-0"	1 3/8"	FLUSH, SC	PT GRADE	PT-1	PT GRADE	PT-1						
	202	BYPASS	4'-8"	7'-0"	1 3/8"	FLUSH, SC	PT GRADE	PT-1	PT GRADE	PT-1						
	203	SWING	2'-8"	7'-0"	1 3/8"	FLUSH, SC	PT GRADE	PT-1	PT GRADE	PT-1						
	204	BYPASS	4'-8"	7'-0"	1 3/8"	FLUSH, SC	PT GRADE	PT-1	PT GRADE	PT-1						
	205	POCKET	2'-8"	7'-0"	1 3/8"	FLUSH, SC	PT GRADE	PT-1	PT GRADE	PT-1						
	206	SWING	2'-8"	7'-0"	1 3/8"	FLUSH, SC	PT GRADE	PT-1	PT GRADE	PT-1						
	207	SWING	2'-8"	7'-0"	1 3/8"	FLUSH, SC	PT GRADE	PT-1	PT GRADE	PT-1						
	208	SWING	2'-8"	7'-0"	1 3/8"	FLUSH, SC	PT GRADE	PT-1	PT GRADE	PT-1						
	209	POCKET	2'-8"	7'-0"	1 3/8"	FLUSH, SC	PT GRADE	PT-1	PT GRADE	PT-1						
	210	POCKET	2'-8"	7'-0"	1 3/8"	FLUSH, SC	PT GRADE	PT-1	PT GRADE	PT-1						



CONTACT
 SHED ARCHITECTURE & DESIGN
 1401 S JACKSON ST
 SEATTLE, WA 98144
 206.320.8700

PROJECT
SULLIVAN
 3024 69th Ave SE
 MERCER ISLAND, WA 98040

ISSUE	DATE
PRE APP #1 (PRE22-0433)	2022.08.16
CAR 2 (CAO22-023)	2022.12.08
PERMIT SET	2023.01.20
REVISION #1	2023.05.26
REVISION #2	2023.07.07

DRAWING TITLE
SCHEDULES

A-602

GENERAL STRUCTURAL NOTES
(THE FOLLOWING APPLY UNLESS SHOWN OTHERWISE ON THE PLANS)

CRITERIA

1. ALL MATERIALS, WORKMANSHIP, DESIGN, AND CONSTRUCTION SHALL CONFORM TO THE DRAWINGS, SPECIFICATIONS, THE INTERNATIONAL BUILDING CODE (2018 EDITION), & CITY OF MERCER ISLAND MODIFICATIONS TO THE INTERNATIONAL BUILDING CODE.

2. DESIGN LOADING CRITERIA:

FLOOR LIVE LOAD (RESIDENTIAL)	40 PSF
FLOOR LIVE LOAD (BALCONIES AND DECKS)	60 PSF
FLOOR LIVE LOAD (UNINHABITABLE ATTICS W/O STORAGE)	10 PSF
FLOOR LIVE LOAD (UNINHABITABLE ATTICS WITH STORAGE)	20 PSF
ROOF SNOW LOAD (Pf)	25 PSF

WIND:

BASIC WIND SPEED (3-SECOND GUST)	100 MPH
WIND IMPORTANCE FACTOR (Iw)	1.0
WIND EXPOSURE	B
TOPOGRAPHICAL FACTOR (Kzt)	1.25

EARTHQUAKE:

LAT. / LONG.	47.583 / -122.246
SEISMIC IMPORTANCE FACTOR (Ie)	1.0
SEISMIC USE GROUP	I
MAPPED SPECTRAL RESPONSE (Ss/S1)	1.56g/0.64g
SPECTRAL RESPONSE COEF. (SDS/SD1)	1.04g/0.77g
SEISMIC FORCE RESISTING SYSTEM	PLYWOOD SHEAR WALLS
DESIGN BASE SHEAR	25.2k
SEISMIC RESPONSE COEFFICIENT (Cs)	0.160
SEISMIC DESIGN CATEGORY	D
RESPONSE MODIFICATION FACTOR (R)	6.5
ANALYSIS PROCEDURE	EQUIVALENT LATERAL FORCE

REFERENCE: USGS NATIONAL SEISMIC HAZARD MAPPING PROJECT, 2008 DATA

3. STRUCTURAL DRAWINGS SHALL BE USED IN CONJUNCTION WITH ARCHITECTURAL DRAWINGS FOR BIDDING AND CONSTRUCTION. CONTRACTOR SHALL VERIFY DIMENSIONS AND CONDITIONS FOR COMPATIBILITY AND SHALL NOTIFY ARCHITECT OF ANY DISCREPANCIES PRIOR TO CONSTRUCTION.

4. CONTRACTOR SHALL DETERMINE THE LOCATION OF ALL ADJACENT UNDERGROUND UTILITIES PRIOR TO COMMENCING EXCAVATION. THE CONTRACTOR SHALL BRING ALL CONFLICTS AND DISCREPANCIES TO THE ATTENTION OF THE ARCHITECT AND STRUCTURAL ENGINEER.

5. CONTRACTOR SHALL VERIFY ALL EXISTING CONDITIONS BEFORE COMMENCING ANY DEMOLITION. SHORING SHALL BE INSTALLED TO SUPPORT EXISTING CONSTRUCTION AS REQUIRED AND IN A MANNER SUITABLE TO THE WORK SEQUENCES. EXISTING REINFORCING SHALL BE RETAINED UNDAMAGED WHERE NOTED ON THE PLANS. DEMOLITION DEBRIS SHALL NOT BE ALLOWED TO DAMAGE OR OVERLOAD THE EXISTING STRUCTURE. LIMIT CONSTRUCTION LOADING (INCLUDING DEMOLITION DEBRIS) ON EXISTING FLOOR SYSTEMS TO 40 PSF. ALL NEW OPENINGS THROUGH EXISTING CONCRETE OR MASONRY WALLS, SLABS AND BEAMS SHALL BE ACCOMPLISHED BY SAW CUTTING WHEREVER POSSIBLE.

6. CONTRACTOR SHALL PROVIDE TEMPORARY BRACING FOR THE STRUCTURE AND STRUCTURAL COMPONENTS UNTIL ALL FINAL CONNECTIONS HAVE BEEN COMPLETED IN ACCORDANCE WITH THE PLANS.

7. CONTRACTOR SHALL BE RESPONSIBLE FOR ALL SAFETY PRECAUTIONS AND THE METHODS, TECHNIQUES, SEQUENCES OR PROCEDURES REQUIRED TO PERFORM THE WORK. THE STRUCTURAL ENGINEER HAS NO OVERALL SUPERVISORY AUTHORITY OR ACTUAL AND/OR DIRECT RESPONSIBILITY FOR THE SPECIFIC WORKING CONDITIONS AT THE SITE AND/OR FOR ANY HAZARDS RESULTING FROM THE ACTIONS OF ANY TRADE CONTRACTOR. THE STRUCTURAL ENGINEER HAS NO DUTY TO INSPECT, SUPERVISE, NOTE, CORRECT, OR REPORT ANY HEALTH OR SAFETY DEFICIENCIES OF THE OWNER, CONTRACTORS, OR OTHER ENTITIES OR PERSONS AT THE PROJECT SITE.

8. SPECIAL INSPECTION OF THE FOLLOWING TYPES OF CONSTRUCTION SHALL BE PROVIDED IN ACCORDANCE WITH SECTIONS 109 AND 1704 OF THE INTERNATIONAL BUILDING CODE AND THE PROJECT SPECIFICATIONS BY A QUALIFIED TESTING AGENCY DESIGNATED BY THE ARCHITECT, AND RETAINED BY THE BUILDING OWNER. THE ARCHITECT, STRUCTURAL ENGINEER, AND BUILDING DEPARTMENT SHALL BE FURNISHED WITH COPIES OF ALL INSPECTION AND TEST RESULTS.

- A. CONCRETE RETAINING WALL CONSTRUCTION
- B. STRUCTURAL STEEL FABRICATION AND ERECTION (INCLUDING FIELD WELDING AND HIGH-STRENGTH FIELD BOLTING)
- C. AUGERCAST PILE, CAISSON, OR DRIVEN PILE INSTALLATION

9. STRUCTURAL OBSERVATION SHALL BE PERFORMED IN ACCORDANCE WITH SECTIONS 1702 AND 1709 OF THE LOCAL OR INTERNATIONAL BUILDING CODE FOR THOSE STRUCTURAL ELEMENTS THAT FORM THE LATERAL-FORCE-RESISTING SYSTEM, AS FOLLOWS:

- A. PLYWOOD ROOF AND FLOOR DIAPHRAGMS, INCLUDING COLLECTORS
- B. PLYWOOD SHEARWALLS, INCLUDING STRAPS AND HOLDOWNS

THE CONTRACTOR SHALL PROVIDE THE ENGINEER OF RECORD ADEQUATE NOTICE TO SCHEDULE APPROPRIATE SITE VISITS FOR STRUCTURAL OBSERVATION, AS FOLLOWS:

- A. DURING FOUNDATION AND CONCRETE CONSTRUCTION -AFTER REBAR, HOLDOWN AND ANCHOR BOLT PLACEMENT, BUT PRIOR TO CONCRETE PLACEMENT.
- B. DURING FRAMING -AFTER HOLDOWN AND STRAP INSTALLATION, AND AFTER SHEARWALL AND DIAPHRAGM NAILING, BUT PRIOR TO COVER WITH INTERIOR OR EXTERIOR FINISHES, INCLUDING ROOFING AND BUILDING PAPER.
- C. DURING STEEL CONSTRUCTION -AFTER STEEL ERECTION AND WELDING, BUT PRIOR TO COVER WITH FINISHES OR OTHER STRUCTURE SUCH AS NAILERS.

STRUCTURAL OBSERVATION MEANS THE VISUAL OBSERVATION OF THE STRUCTURAL SYSTEM BY THE REGISTERED DESIGN PROFESSIONAL FOR GENERAL CONFORMANCE TO THE APPROVED CONSTRUCTION DOCUMENTS. STRUCTURAL OBSERVATION DOES NOT INCLUDE OR WAIVE THE RESPONSIBILITY FOR THE INSPECTIONS REQUIRED BY SECTION 110, 1704 OR OTHER SECTIONS OF THE CODE. THE OWNER SHALL EMPLOY THE ENGINEER RESPONSIBLE FOR THE STRUCTURAL DESIGN TO PERFORM STRUCTURAL OBSERVATION.

OBSERVED DEFICIENCIES WILL BE REPORTED IN WRITING TO THE ARCHITECT AND CONTRACTOR. RECOMMENDATIONS FOR MITIGATION OF DEFICIENCIES WILL BE INCLUDED IN THESE REPORTS. THE CONTRACTOR SHALL MITIGATE ANY DEFICIENCIES FOUND AND PROVIDE THE ENGINEER OF RECORD ADEQUATE NOTICE TO SCHEDULE APPROPRIATE SITE VISITS TO OBSERVE THE MITIGATION OF THE DEFICIENCIES.

AT THE CONCLUSION OF THE WORK INCLUDED IN THE PERMIT, THE STRUCTURAL OBSERVER WILL SUBMIT TO THE BUILDING OFFICIAL A WRITTEN STATEMENT THAT THE SITE VISITS NOTED ABOVE HAVE BEEN MADE AND WILL IDENTIFY ANY REPORTED DEFICIENCIES WHICH TO THE BEST OF THE STRUCTURAL OBSERVER'S KNOWLEDGE HAVE NOT BEEN MADE.

10. SHOP DRAWINGS FOR THE FOLLOWING ITEMS SHALL BE SUBMITTED TO THE ARCHITECT AND STRUCTURAL ENGINEER FOR REVIEW PRIOR TO FABRICATION OF THESE ITEMS.

- A. STRUCTURAL STEEL
- B. GLUED LAMINATED MEMBERS
- C. PLYWOOD WEB JOISTS

APPROVED SETS OF ALL SHOP DRAWINGS SHALL ALSO BE SUBMITTED TO THE BUILDING DEPARTMENT.

GEOTECHNICAL

11. FOUNDATION NOTES: SUBGRADE PREPARATION INCLUDING DRAINAGE, EXCAVATION, COMPACTION, AND FILLING REQUIREMENTS, SHALL CONFORM STRICTLY WITH RECOMMENDATIONS GIVEN IN THE SOILS REPORT OR AS DIRECTED BY THE SOILS ENGINEER. FOOTINGS SHALL BEAR ON SOLID UNDISTURBED EARTH (CONTROLLED, COMPACTED STRUCTURAL FILL OR BOTH) AT LEAST 18" BELOW LOWEST ADJACENT FINISHED GRADE. FOOTING DEPTHS/ELEVATIONS SHOWN ON PLANS (OR IN DETAILS) ARE MINIMUM AND FOR GUIDANCE ONLY; THE ACTUAL ELEVATIONS OF FOOTINGS MUST BE ESTABLISHED BY THE CONTRACTOR IN THE FIELD WORKING WITH THE TESTING LAB AND SOILS ENGINEER. BACKFILL BEHIND ALL RETAINING WALLS WITH FREE DRAINING GRANULAR FILL AND PROVIDE FOR SUBSURFACE DRAINAGE AS NOTED IN THE SOILS REPORT.

ALLOWABLE SOIL PRESSURE	2500 PSF
LATERAL EARTH PRESSURE	55 PCF

SOILS REPORT REFERENCE: COBALT GEOSCIENCES 3024 69TH AVE SE REPORT UPDATED JUNE 27, 2023

CONCRETE

12. CONCRETE SHALL BE MIXED, PROPORTIONED, CONVEYED AND PLACED IN ACCORDANCE WITH IBC SECTION 1905 AND ACI 301. CONCRETE SHALL ATTAIN A 28DAY STRENGTH OF F' C = 2,500 PSI. THE CONCRETE MIX SHALL CONTAIN A MAXIMUM OF 330 POUNDS OF CEMENT PER CUBIC YARD AND SHALL HAVE A HIGH (30 PERCENT OR MORE) SCM (SUPPLEMENTARY CEMENTITIOUS MATERIALS, SUCH AS FLYASH OR SLAG) CONTENT. CEMENT SHALL BE A BLENDED HYDRAULIC CEMENT CONFORMING TO ASTM C595.

A CONCRETE PERFORMANCE MIX SHALL BE SUBMITTED TO THE ARCHITECT, STRUCTURAL ENGINEER AND THE BUILDING DEPARTMENT FOR APPROVAL TWO WEEKS PRIOR TO PLACING ANY CONCRETE. THE CONCRETE PERFORMANCE MIX SHALL INCLUDE THE AMOUNTS OF CEMENT, SUPPLEMENTARY CEMENTITIOUS MATERIALS, FINE AND COARSE AGGREGATE, WATER AND ADMIXTURES AS WELL AS THE WATER CEMENT RATIO, SLUMP, CONCRETE YIELD & SUBSTANTIATING STRENGTH DATA IN ACCORDANCE WITH ARTICLE 4.2.3 OF ACI 301. REVIEW OF MIX SUBMITTALS BY THE ENGINEER OF RECORD INDICATES ONLY THAT INFORMATION PRESENTED CONFORMS GENERALLY WITH CONTRACT DOCUMENTS. CONTRACTOR OR SUPPLIER MAINTAINS FULL RESPONSIBILITY FOR SPECIFIED PERFORMANCE.

ALL CONCRETE WITH SURFACES EXPOSED TO STANDING WATER SHALL BE AIR - ENTRAINED WITH AN AIR ENTRAINING AGENT CONFORMING TO ASTM C260, C494, AND C618. TOTAL AIR CONTENT SHALL BE IN ACCORDANCE WITH TABLE 19.3.2.1 OF THE ACI 318.

13. REINFORCING STEEL SHALL CONFORM TO ASTM A615 (INCLUDING SUPPLEMENT S1), GRADE 60, FY = 60,000 PSI. WELDED WIRE FABRIC SHALL CONFORM TO ASTM A185.

14. REINFORCING STEEL SHALL BE DETAILED (INCLUDING HOOKS AND BENDS) IN ACCORDANCE WITH ACI 318. LAP ALL CONTINUOUS REINFORCEMENT 40 BAR DIAMETERS OR 2' 0" MINIMUM. PROVIDE CORNER BARS AT ALL WALL AND FOOTING INTERSECTIONS. LAP CORNER BARS 40 BAR DIAMETERS OR 2' 0" MINIMUM. LAP ADJACENT MATS OF WELDED WIRE FABRIC A MINIMUM OF 8" AT SIDES AND ENDS.

15. CONCRETE PROTECTION (COVER) FOR REINFORCING STEEL SHALL BE AS FOLLOWS:
A. FOOTINGS AND OTHER UNFORMED SURFACES, EARTH FACE . . . 3"
B. ALL OTHER SURFACES 1 1/2"

16. NON-SHRINK GROUT SHALL BE FURNISHED BY AN APPROVED MANUFACTURER AND SHALL BE MIXED AND PLACED IN STRICT ACCORDANCE WITH THE MANUFACTURER'S PUBLISHED RECOMMENDATIONS. GROUT STRENGTH SHALL BE AT LEAST EQUAL TO THE MATERIAL ON WHICH IT IS PLACED (3000 PSI MINIMUM).

ANCHORAGE

17. EXPANSION BOLTS INTO CONCRETE AND GROUTED MASONRY UNITS SHALL BE "STRONG-BOLT" ANCHORS AS MANUFACTURED BY THE SIMPSON COMPANY AND INSTALLED IN STRICT ACCORDANCE WITH ICC ESR 1771, INCLUDING MINIMUM EMBEDMENT REQUIREMENTS.

18. EPOXY-GROUTED ITEMS SPECIFIED ON THE DRAWINGS SHALL BE GROUTED WITH "SET-XP" HIGH STRENGTH EPOXY AS MANUFACTURED BY THE SIMPSON COMPANY AND INSTALLED IN STRICT ACCORDANCE WITH ICC ESR 2508.

19. TITEN HD ANCHORS SPECIFIED ON THE DRAWINGS SHALL CONSIST OF "TITEN HD" HEAVY DUTY SCREW ANCHORS AS MANUFACTURED BY THE SIMPSON COMPANY AND INSTALLED IN STRICT ACCORDANCE WITH ICC ESR 2713.

STEEL

20. STRUCTURAL STEEL DESIGN, FABRICATION, AND ERECTION SHALL BE BASED ON THE LATEST EDITIONS OF THE AISC SPECIFICATIONS AND CODES:

- A. SPECIFICATION FOR STRUCTURAL STEEL BUILDINGS (AISC 360)
- B. CODE OF STANDARD PRACTICE FOR STEEL BUILDINGS AND BRIDGES (AISC 303)
- C. SPECIFICATION FOR STRUCTURAL JOINTS USING ASTM A325 OR A490 BOLTS. BOLTS IN SHEAR OR BEARING TYPE CONNECTIONS NEED ONLY BE TIGHTENED TO THE SNUG TIGHT CONDITION PER SECTION 8(C).

21. STRUCTURAL STEEL SHALL CONFORM TO THE FOLLOWING MINIMUM STANDARDS. PLATES, ANGLES, AND CHANNELS SHALL CONFORM TO ASTM A36, FY = 36 KSI. WIDE FLANGE SHAPES SHALL CONFORM TO ASTM A992, FY = 50 KSI. STEEL PIPE SHALL CONFORM TO ASTM A53, TYPE E OR S, GRADE B, FY = 35 KSI. SQUARE OR RECTANGULAR STRUCTURAL TUBING SHALL CONFORM TO ASTM A500, GRADE B, FY = 46 KSI. ANCHOR BOLTS AND CONNECTION BOLTS SHALL CONFORM TO ASTM A307. THREADED ROD AND STUDS SHALL CONFORM TO ASTM A36.

22. ALL WELDING SHALL BE IN CONFORMANCE WITH AISC AND AWS STANDARDS AND SHALL BE PERFORMED BY WABO CERTIFIED WELDERS USING E70XX ELECTRODES. ONLY PREQUALIFIED WELDS (AS DEFINED BY AWS) SHALL BE USED.

HV

Harriott Valentine Engineers Inc.
1932 First Avenue, Suite 720
Seattle, Washington 98101-2447
tel 206 624 4760 fax 206 447 6971
www.harriottvalentine.com

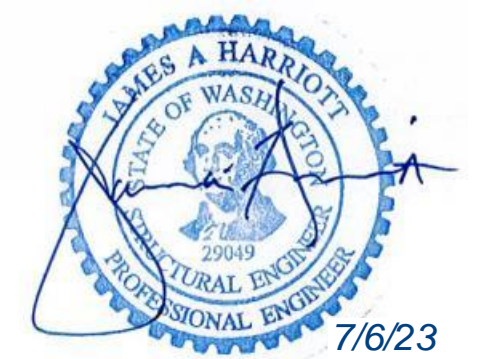

Project Contact
Conrad Beymer
tel 206 756 0391
fax 206 447 6971
cbeymer@harriottvalentine.com

Project Architect
SHED Architecture & Design
1404 S Jackson Street
Seattle, WA 98144

Project
Sullivan Residence
3024 69th Ave SE
Mercer Island, WA 98040

Issue Date	Issue Description
01/20/2023	Permit
05/18/2023	Corrections
07/04/2023	Corrections

Building Department Approval

[Empty box for Building Department Approval]

Drawing Title
GENERAL STRUCTURAL NOTES

Drawing Number

S1.0

SULLIVAN RESIDENCE

WOOD

23. FRAMING LUMBER SHALL BE KILN DRIED OR MC-15, AND GRADED AND MARKED IN CONFORMANCE WITH WCLIB STANDARD GRADING RULES FOR WEST COAST LUMBER NO. 17, LATEST EDITION. FURNISH TO THE FOLLOWING MINIMUM STANDARDS:

JOISTS: (2X MEMBERS)	HEM-FIR NO. 2 MINIMUM BASE VALUE, FB = 850 PSI
(3X & 4X MEMBERS)	DOUGLAS FIR NO. 1 MINIMUM BASE VALUE, FB = 1000 PSI
STRUCTURAL LIGHT FRAMING: (INCL. 3X AND 4X POSTS)	DOUGLAS FIR NO. 2 MINIMUM BASE VALUE, FB = 900 PSI
BEAMS AND STRINGERS: (INCL. 6X AND LARGER)	DOUGLAS FIR NO. 1 MINIMUM BASE VALUE, FB = 1350 PSI
POSTS AND TIMBERS: (6X6 AND LARGER)	DOUGLAS FIR NO. 1 MINIMUM BASE VALUE, FC = 1000 PSI
STUDS, PLATES & MISC. FRAMING:	DOUGLAS FIR OR HEM-FIR STANDARD GRADE
2X6 STUDS AND PLATES:	HEM-FIR NO.3/ STUD GRADE
2X AND 3X T & G DECKING	HEM-FIR COMMERCIAL DEX, MINIMUM BASE VALUE, FB = 1350 PSI

24. GLUED LAMINATED MEMBERS SHALL BE FABRICATED IN CONFORMANCE WITH ASTM AND AITC STANDARDS. EACH MEMBER SHALL BEAR AN AITC IDENTIFICATION MARK AND SHALL BE ACCOMPANIED BY AN AITC CERTIFICATE OF CONFORMANCE. ALL SIMPLE SPAN BEAMS SHALL BE DOUGLAS FIR COMBINATION 24FV4, FB = 2,400 PSI, FV = 165 PSI. ALL CANTILEVERED BEAMS SHALL BE DOUGLAS FIR COMBINATION 24FV8, FB = 2400 PSI, FV = 165 PSI. CAMBER ALL SIMPLE SPAN GLULAM BEAMS TO 2,000' RADIUS, UNLESS SHOWN OTHERWISE ON THE PLANS. ALL COLUMNS SHALL BE DOUGLAS FIR COMBINATION NO. 5, FC = 2400 PSI, E = 2.0 X 10E6 PSI.

25. ENGINEERED LUMBER MEMBERS SHALL BE MANUFACTURED UNDER A PROCESS BY THE NATIONAL RESEARCH BOARD. EACH PIECE SHALL BEAR A STAMP OR STAMPS NOTING THE NAME AND PLANT NUMBER OF THE MANUFACTURER, THE GRADE, THE NATIONAL RESEARCH BOARD NUMBER, AND THE QUALITY CONTROL AGENCY. ALL LUMBER SHALL BE MANUFACTURED IN ACCORDANCE WITH THE APPROPRIATE NER REPORT AND GLUED WITH A WATERPROOF ADHESIVE MEETING THE REQUIREMENTS OF ASTM D2559 WITH ALL GRAIN PARALLEL WITH THE LENGTH OF THE MEMBER.

PSL	FB = 2900 PSI	E = 2000 KSI	FV = 290 PSI	NER-292
LSL	FB = 2250 PSI	E = 1500 KSI	FV = 285 PSI	NER-481
LVL	FB = 2600 PSI	E = 1800 KSI	FV = 285 PSI	NER-126

DESIGN SHOWN ON PLANS IS BASED ON LUMBER MANUFACTURED BY THE WEYERHAUSER CORPORATION. ALTERNATE MANUFACTURERS MAY BE USED SUBJECT TO REVIEW AND APPROVAL BY THE ARCHITECT AND STRUCTURAL ENGINEER. ALTERNATE JOIST HANGERS AND OTHER HARDWARE MAY BE SUBSTITUTED FOR ITEMS SHOWN PROVIDED THEY HAVE ICC APPROVAL FOR EQUAL OR GREATER LOAD CAPACITIES. ALL JOIST HANGERS AND OTHER HARDWARE SHALL BE COMPATIBLE IN SIZE WITH MEMBERS PROVIDED.

ALL PROPOSED HOLE SIZES AND LOCATIONS SHALL BE SUBMITTED TO THE STRUCTURAL ENGINEER FOR APPROVAL TWO WORKING DAYS PRIOR TO DRILLING HOLES.

26. PREFABRICATED PLYWOOD WEB JOIST DESIGN SHOWN ON PLANS IS BASED ON JOISTS MANUFACTURED BY THE WEYERHAUSER CORPORATION AND SHALL BE FURNISHED AND INSTALLED IN CONFORMANCE WITH THE MANUFACTURER'S PUBLISHED SPECIFICATIONS. ALL NECESSARY BRIDGING, BLOCKING, BLOCKING PANELS, STIFFENERS, ETC., SHALL BE DETAILED AND FURNISHED BY THE MANUFACTURER. SUBMIT SHOP DRAWINGS TO THE ARCHITECT AND STRUCTURAL ENGINEER FOR REVIEW PRIOR TO FABRICATION. ALTERNATE PLYWOOD WEB JOIST MANUFACTURERS MAY BE USED SUBJECT TO REVIEW AND APPROVAL BY THE ARCHITECT AND STRUCTURAL ENGINEER. ALTERNATE JOIST HANGERS AND OTHER HARDWARE MAY BE SUBSTITUTED FOR ITEMS SHOWN PROVIDED THEY HAVE ICC APPROVAL FOR EQUAL OR GREATER LOAD CAPACITIES. ALL JOIST HANGERS AND OTHER HARDWARE SHALL BE COMPATIBLE IN SIZE WITH PLYWOOD WEB JOIST PROVIDED.

ALL HOLES SHALL CONFORM TO THE MANUFACTURERS SPECIFICATIONS. IF THREE OR FEWER HOLES ARE PROPOSED FOR A SINGLE JOIST, HOLES SHALL CONFORM TO THE WEYERHAUSER ILEVEL TJI ALLOWABLE HOLE CHART. IF MORE THEN THREE HOLES ARE PROPOSED FOR ONE SINGLE JOIST, ALL HOLE SIZES AND LOCATIONS SHALL BE SUBMITTED TO THE STRUCTURAL ENGINEER FOR APPROVAL TWO WORKING DAYS PRIOR TO DRILLING HOLES.

27. PLYWOOD SHEATHING SHALL BE GRADE C-D, EXTERIOR GLUE OR STRUCTURAL II, EXTERIOR GLUE IN CONFORMANCE WITH APA STANDARDS. ORIENTED STRAND BOARD OF EQUIVALENT THICKNESS, EXPOSURE RATING AND SPAN RATING MAY BE USED IN LIEU OF PLYWOOD.

- A. ROOF SHEATHING SHALL BE 1-1/8" (NOM.) WITH SPAN RATING 48/24.
- B. FLOOR SHEATHING SHALL BE 3/4" (NOM.) WITH SPAN RATING 40/20.
- C. WALL SHEATHING SHALL BE 1/2" (NOM.) WITH SPAN RATING 24/0.

REFER TO WOOD FRAMING NOTES BELOW FOR TYPICAL NAILING.

28. ALL WOOD IN DIRECT CONTACT WITH CONCRETE OR MASONRY SHALL BE PRESSURE-TREATED WITH AN APPROVED PRESERVATIVE OR (2) LAYERS OF ASPHALT IMPREGNATED BUILDING PAPER SHALL BE PROVIDED BETWEEN UNTREATED WOOD AND CONCRETE OR MASONRY. ALL WOOD EXPOSED TO WEATHER WITHOUT THE ADEQUATE PROTECTION OF A ROOF OR EAVE SHALL BE AN APPROVED WOOD OF NATURAL RESISTANCE TO DECAY OR PRESSURE TREATED. SUCH MEMBERS INCLUDE HORIZONTAL MEMBERS SUCH AS GIRDERS, JOISTS, AND DECKING; OR VERTICAL MEMBERS SUCH AS POSTS, POLES, AND COLUMNS.

29. TIMBER CONNECTORS CALLED OUT BY LETTERS AND NUMBERS SHALL BE "STRONG-TIE" BY SIMPSON COMPANY, AS SPECIFIED IN THEIR MOST RECENT CATALOG. EQUIVALENT DEVICES BY OTHER MANUFACTURERS MAY BE SUBSTITUTED, PROVIDED THEY HAVE ICC APPROVAL FOR EQUAL OR GREATER LOAD CAPACITIES. PROVIDE NUMBER AND SIZE OF FASTENERS AS SPECIFIED BY MANUFACTURER. CONNECTORS SHALL BE INSTALLED IN ACCORDANCE WITH THE MANUFACTURER'S RECOMMENDATIONS. WHERE CONNECTOR STRAPS CONNECT TWO MEMBERS, PLACE ONE-HALF OF THE NAILS OR BOLTS IN EACH MEMBER. ALL BOLTS IN WOOD MEMBERS SHALL CONFORM TO ASTM A307. PROVIDE WASHERS UNDER THE HEADS AND NUTS OF ALL BOLTS AND LAG SCREWS BEARING ON WOOD. UNLESS NOTED OTHERWISE, ALL NAILS SHALL BE COMMON. ALL SHIMS SHALL BE SEASONED AND DRIED AND THE SAME GRADE (MIN.) AS MEMBERS CONNECTED.

CONNECTORS OUTSIDE OF THE BUILDING ENVELOPE (E.G. EAVES) SHALL BE EITHER STAINLESS STEEL (SST300), POST HOT-DIP GALVANIZED(HDG) OR GALVANIZED WITH A MINIMUM OF 1.850Z ZINC PER SQUARE INCH (ZMAX).

CONNECTORS IN DIRECT CONTACT WITH PRESERVATIVE-TREATED WOOD THAT IS EXPOSED TO WEATHER (E.G. DECKS) SHALL BE STAINLESS STEEL (SST300).

CONNECTORS IN DIRECT CONTACT WITH PRESERVATIVE-TREATED WOOD THAT IS WITHIN THE BUILDING ENVELOPE (E.G. LEDGERS AND SILLS) SHALL BE EITHER STAINLESS STEEL SST300), POST HOT-DIP GALVANIZED(HDG) OR GALVANIZED WITH A MINIMUM OF 1.850Z ZINC PER SQUARE INCH (ZMAX).

FASTENERS USED WITH STAINLESS STEEL CONNECTORS SHALL BE STAINLESS STEEL (TYPE 303, 304, 305, OR 316). FASTENERS FOR HOT-DIP GALVANIZED OR ZMAX CONNECTORS SHALL BE HOT-DIP GALVANIZED.

30. NAILS - NAIL SIZES SPECIFIED ON DRAWINGS ARE BASED ON THE FOLLOWING SPECIFICATIONS:

SIZE	LENGTH	DIAMETER
6D	2"	0.113"
8D	2-1/2"	0.131"
10D	3"	0.148"
12D	3-1/4"	0.148"
16D	3-1/2"	0.162"

IF CONTRACTOR PROPOSES THE USE OF ALTERNATE NAILS, THEY SHALL SUBMIT NAIL SPECIFICATIONS TO THE STRUCTURAL ENGINEER (PRIOR TO CONSTRUCTION) FOR REVIEW AND APPROVAL. NAILS SHALL BE DRIVEN FLUSH TO FACE OF SHEATHING WITH NO COUNTERSINKING PERMITTED.

31. STAPLES - THE FOLLOWING STAPLES MAY BE SUBSTITUTED FOR NAILING OF PLYWOOD (APA RATED SHEATHING):

NAIL SIZE	EQUIV. STAPLE	MINIMUM LENGTH
6D	16 GA.	1-3/4"
8D	15 GA.	1-3/4"
10D	13 GA.	1-3/4"

IF CONTRACTOR PROPOSES THE USE OF ALTERNATE STAPLES, THEY SHALL SUBMIT STAPLE SPECIFICATIONS TO THE STRUCTURAL ENGINEER (PRIOR TO CONSTRUCTION) FOR REVIEW AND APPROVAL. STAPLES SHALL BE DRIVEN FLUSH TO FACE OF SHEATHING WITH NO COUNTERSINKING PERMITTED.

32. WOOD FRAMING NOTESTHE FOLLOWING APPLY UNLESS OTHERWISE SHOWN:

- A. ALL WOOD FRAMING DETAILS NOT SHOWN OTHERWISE SHALL BE CONSTRUCTED TO THE MINIMUM STANDARDS OF THE INTERNATIONAL BUILDING CODE. MINIMUM NAILING, UNLESS OTHERWISE NOTED, SHALL CONFORM TO TABLE 2304.10.1 OF THE INTERNATIONAL BUILDING CODE. UNLESS NOTED OTHERWISE, ALL NAILS SHALL BE COMMON. COORDINATE THE SIZE AND LOCATION OF ALL OPENINGS WITH MECHANICAL AND ARCHITECTURAL DRAWINGS. PROVIDE WASHERS UNDER THE HEADS AND NUTS OF ALL BOLTS AND LAG SCREWS BEARING ON WOOD.

B. WALL FRAMING: ALL STUD WALLS SHOWN AND NOT OTHERWISE NOTED SHALL BE 2X4 STUDS @ 16" O.C. AT INTERIOR WALLS AND 2X6 @ 16" O.C. AT EXTERIOR WALLS. TWO STUDS MINIMUM SHALL BE PROVIDED AT THE END OF ALL WALLS AND AT EACH SIDE OF ALL OPENINGS. TWO 2X8 HEADERS SHALL BE PROVIDED OVER ALL OPENINGS NOT OTHERWISE NOTED. SOLID BLOCKING FOR WOOD COLUMNS SHALL BE PROVIDED THROUGH FLOORS TO SUPPORTS BELOW. WALLS SHALL HAVE A SINGLE BOTTOM PLATE AND A DOUBLE TOP PLATE. END NAIL TOP PLATE TO EACH STUD WITH TWO 16D NAILS, AND TOENAIL OR END NAIL EACH STUD TO BOTTOM PLATE WITH TWO 16D NAILS. FACE NAIL DOUBLE TOP PLATE WITH 16D AT 12" O.C. AND LAP MINIMUM 4'-0" AT JOINTS AND PROVIDE SIX 16D NAILS AT 4" O.C. EACH SIDE OF JOINT. ALL STUD WALLS SHALL HAVE THEIR LOWER WOOD PLATES ATTACHED TO WOOD FRAMING BELOW WITH 16D NAILS AT 12" O.C. STAGGERED OR BOLTED TO CONCRETE WITH 5/8" DIAMETER ANCHOR BOLTS (WITH 7" MINIMUM EMBEDMENT)@ 4'0" O.C. UNLESS INDICATED OTHERWISE. INDIVIDUAL MEMBERS OF BUILTUP POSTS SHALL BE NAILED TO EACH OTHER WITH 16D @ 12" O.C. STAGGERED. REFER TO THE PLANS AND SHEAR WALL SCHEDULE FOR REQUIRED SHEATHING AND NAILING. WHEN NOT OTHERWISE NOTED, PROVIDE GYPSUM WALLBOARD ON INTERIOR SURFACES NAILED TO ALL STUDS, TOP AND BOTTOM PLATES AND BLOCKING WITH NAILS AT 7" O.C. USE 5D COOLER NAILS FOR 1/2" GWB AND 6D COOLER NAILS FOR 5/8" GWB. WHEN NOT OTHERWISE NOTED, PROVIDE 1/2" (NOM.) APA RATED SHEATHING (SPAN RATING 24/0) ON EXTERIOR SURFACES NAILED AT ALL PANEL EDGES (BLOCK UNSUPPORTED EDGES), TOP AND BOTTOM PLATES WITH 8D @ 6" O.C. AND TO ALL INTERMEDIATE STUDS AND BLOCKING WITH 8D @ 12" O.C. ALLOW 1/8" SPACING AT ALL PANEL EDGES AND ENDS.

C. FLOOR AND ROOF FRAMING: PROVIDE DOUBLE JOISTS AROUND ALL OPENINGS IN FLOORS OR ROOFS UNLESS OTHERWISE NOTED. PROVIDE SOLID BLOCKING AT ALL BEARING POINTS. TOENAIL JOISTS TO SUPPORTS WITH TWO 16D NAILS. ATTACH TIMBER JOISTS TO FLUSH HEADERS OR BEAMS WITH METAL JOIST HANGERS IN ACCORDANCE WITH TIMBER CONNECTOR NOTE. NAIL ALL MULTIJOST BEAMS TOGETHER WITH 16D @ 12" O.C. STAGGERED. UNLESS OTHERWISE NOTED ON THE PLANS, ROOF AND FLOOR SHEATHING SHALL BE LAID UP WITH STRENGTH AXIS PERPENDICULAR TO SUPPORTS AND NAILED WITH 8D NAILS @ 6" O.C. TO FRAMED PANEL EDGES AND OVER STUD WALLS AS SHOWN ON PLANS AND @ 12" O.C. TO INTERMEDIATE SUPPORTS. PROVIDE APPROVED PLYWOOD EDGE CLIPS CENTERED BETWEEN JOISTS/TRUSSES AT UNBLOCKED ROOF SHEATHING EDGES. ALL FLOOR SHEATHING EDGES SHALL HAVE APPROVED TONGUEANDGROOVE JOINTS OR SHALL BE SUPPORTED WITH SOLID BLOCKING. ALLOW 1/8" SPACING AT ALL PANEL EDGES AND ENDS OF ALL ROOF AND FLOOR SHEATHING. TOENAIL BLOCKING TO SUPPORTS WITH 16D @ 12" O.C. UNLESS OTHERWISE NOTED. AT BLOCKED FLOOR AND ROOF DIAPHRAGMS PROVIDE FLAT 2X BLOCKING AT ALL UNFRAMED PLYWOOD PANEL EDGES AND NAIL WITH EDGE NAILING SPECIFIED.

HV

Harriott Valentine Engineers Inc.
1932 First Avenue, Suite 720
Seattle, Washington 98101-2447
tel 206 624 4760 fax 206 447 6971
www.harriottvalentine.com



Project Contact
Conrad Beymer
tel 206 756 0391
fax 206 447 6971
cbeymer@harriottvalentine.com

Project Architect
SHED Architecture & Design
1404 S Jackson Street
Seattle, WA 98144

Project
Sullivan Residence
3024 69th Ave SE
Mercer Island, WA 98040

Issue Date	Issue Description
01/20/2023	Permit
05/18/2023	Corrections
07/04/2023	Corrections

Building Department Approval

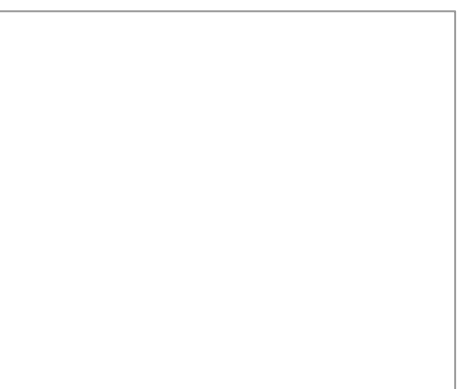

Drawing Title
GENERAL STRUCTURAL NOTES

Drawing Number

S1.1

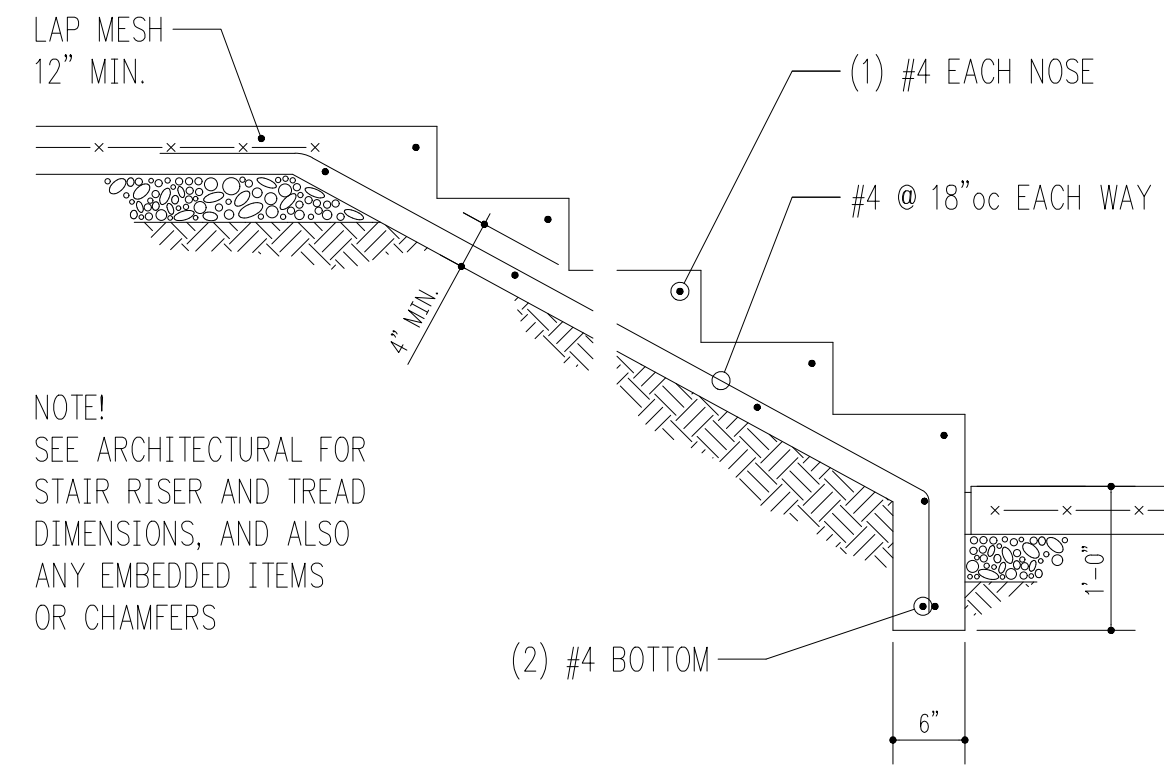

NOTE!
SEE ARCHITECTURAL FOR
STAIR RISER AND TREAD
DIMENSIONS, AND ALSO
ANY EMBEDDED ITEMS
OR CHAMFERS

TYPICAL STAIR-ON-GRADE

3/4" = 1'-0"

2

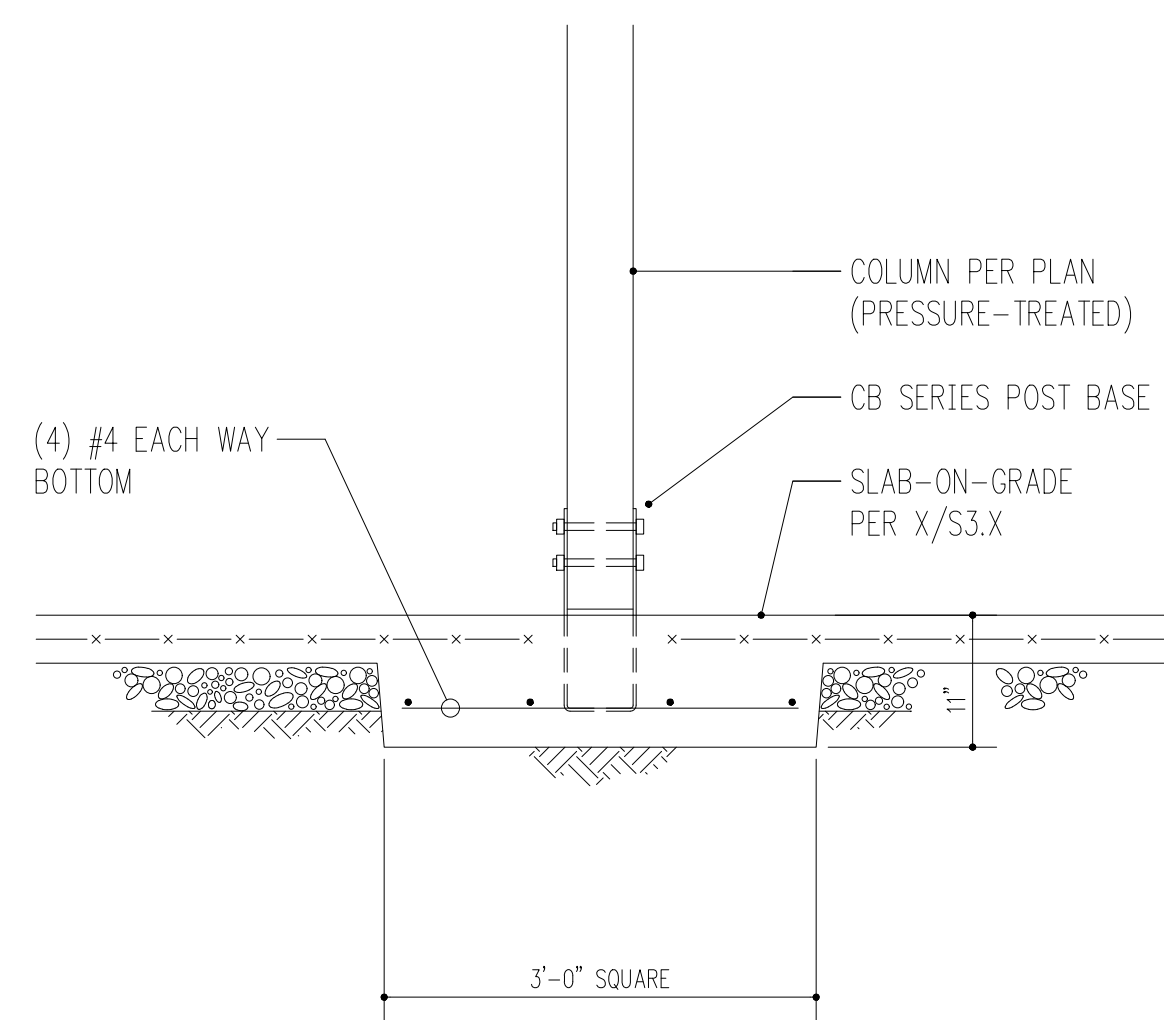

3/4" = 1'-0"

3

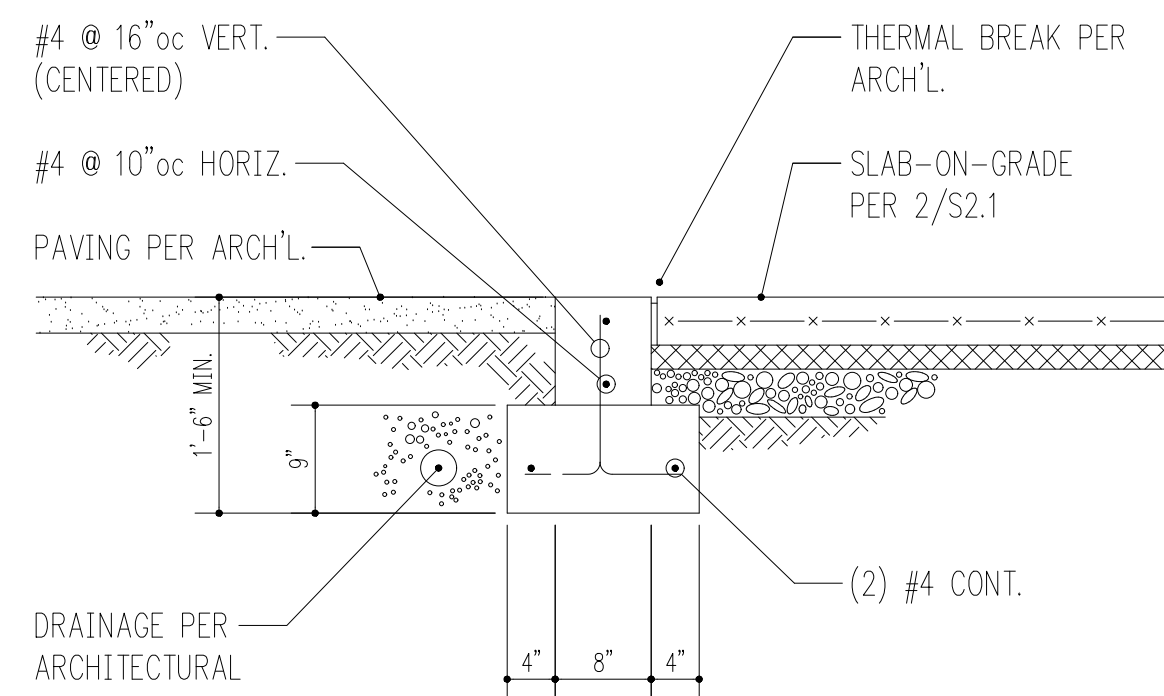

3/4" = 1'-0"

4

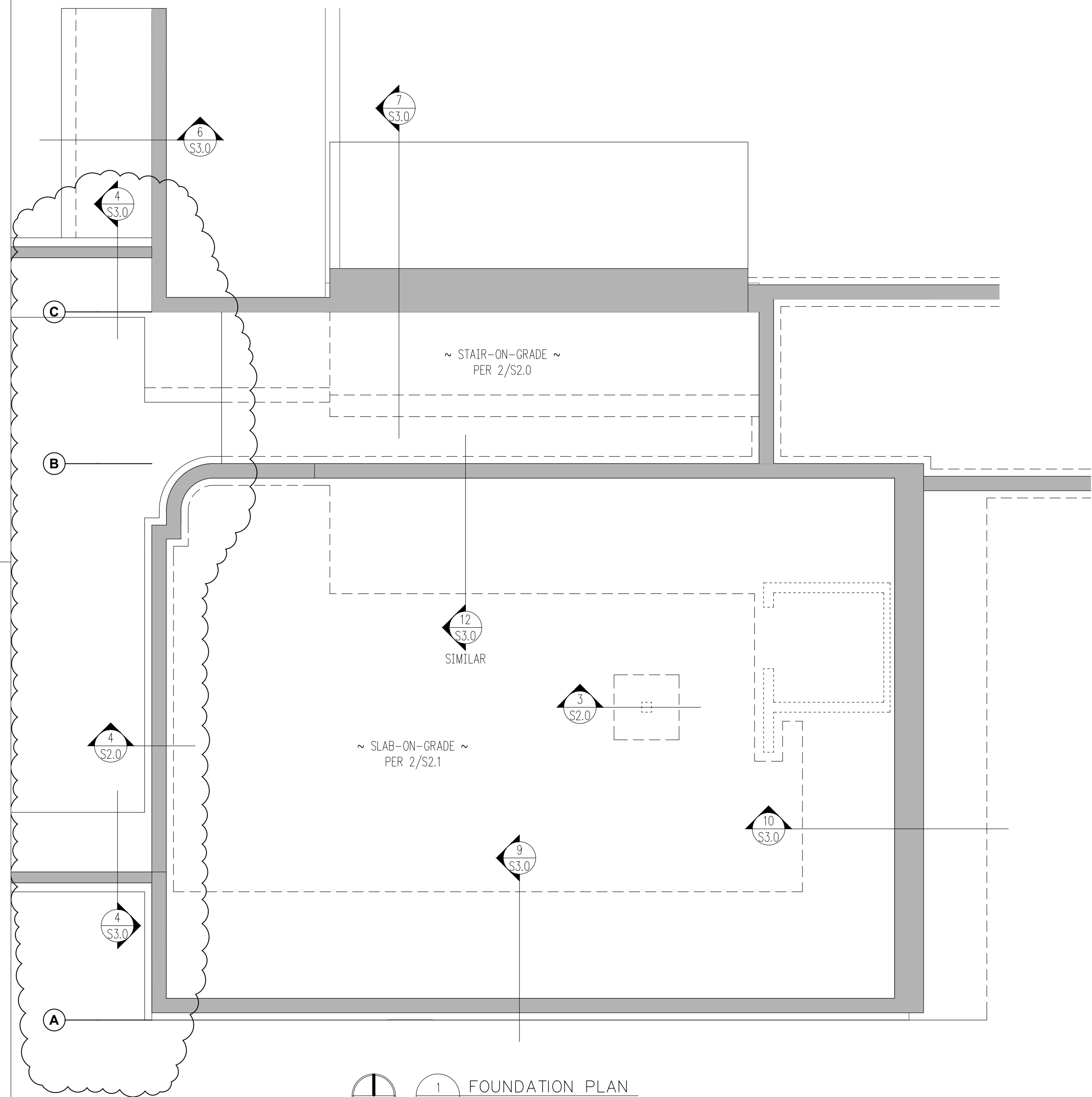

1 FOUNDATION PLAN
scale: 1/4" = 1'-0"

- LEGEND
- SPAN
 - EXTENT
 - SECTION DETAIL
 - FLUSH BEAM
 - PRESSURE-TREATED
 - COLUMN ABOVE
 - COLUMN BELOW
 - NEW STRUCTURAL WALL
 - NEW SHEARWALL
 - NEW CONCRETE WALL
 - ALL-THREAD HOLDOWN AT END OF SHEARWALL ABOVE
 - STRAP HOLDOWN AT END OF SHEARWALL ABOVE

- PLAN NOTES
1. SEE 10/S4.0 FOR TYPICAL HOLDOWN REQUIREMENTS AT CONCRETE WALLS AND FOOTINGS.
 2. SLAB-ON-GRADE SHALL BE PLACED AND CURED FOR A MINIMUM OF SEVEN DAYS BEFORE RETAINING WALLS ARE BACKFILLED. SEE RETAINING WALL DETAILS FOR SPECIFIC CONFIGURATION.

HV
Harriott Valentine Engineers Inc.
1932 First Avenue, Suite 720
Seattle, Washington 98101-2447
tel 206 624 4760 fax 206 447 6971
www.harriottvalentine.com



Project Contact
Conrad Beymer
tel 206 756 0391
fax 206 447 6971
cbeymer@harriottvalentine.com

Project Architect
SHED Architecture & Design
1404 S Jackson Street
Seattle, WA 98144

Project
Sullivan Residence
3024 69th Ave SE
Mercer Island, WA 98040

Issue Date	Issue Description
01/20/2023	Permit
05/18/2023	Corrections
07/04/2023	Corrections

Building Department Approval

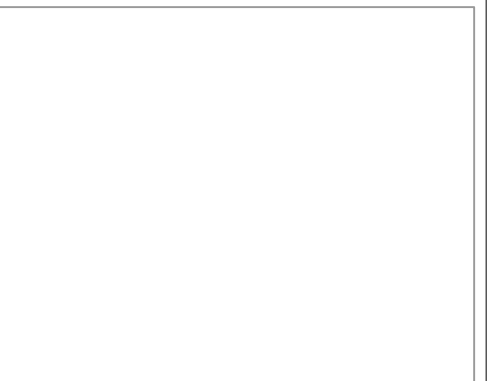

Drawing Title
FOUNDATION PLAN

Drawing Number
S2.0

SULLIVAN RESIDENCE

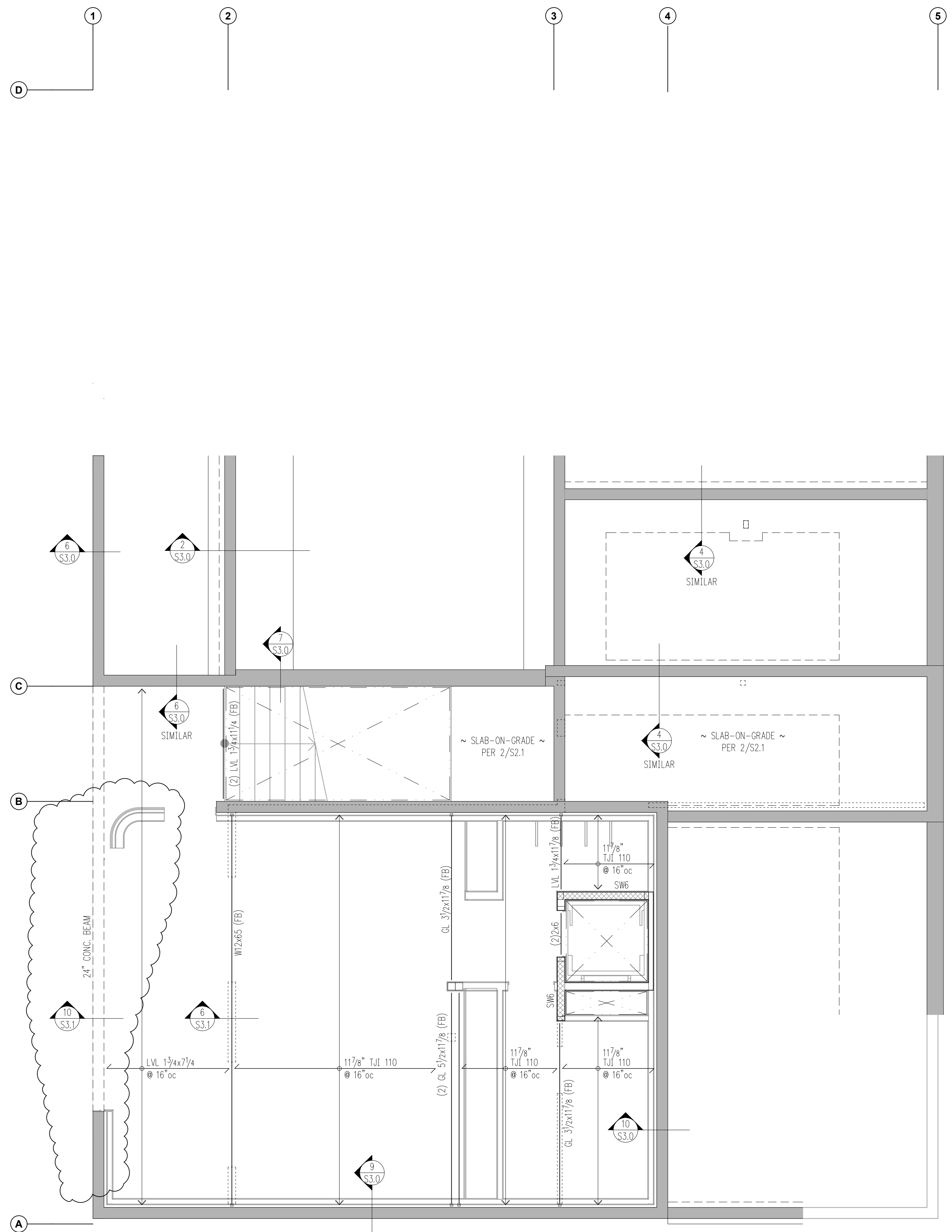
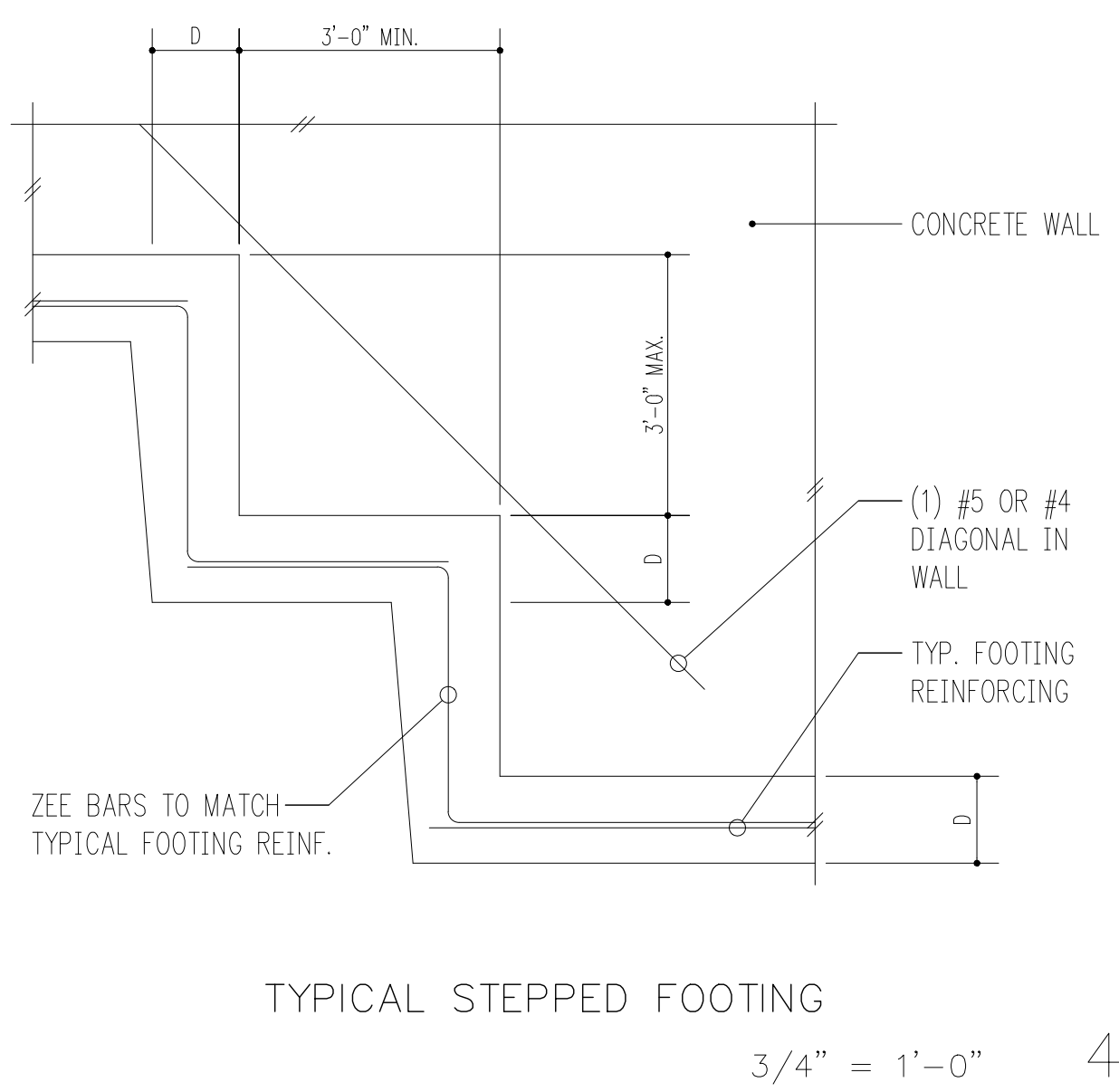
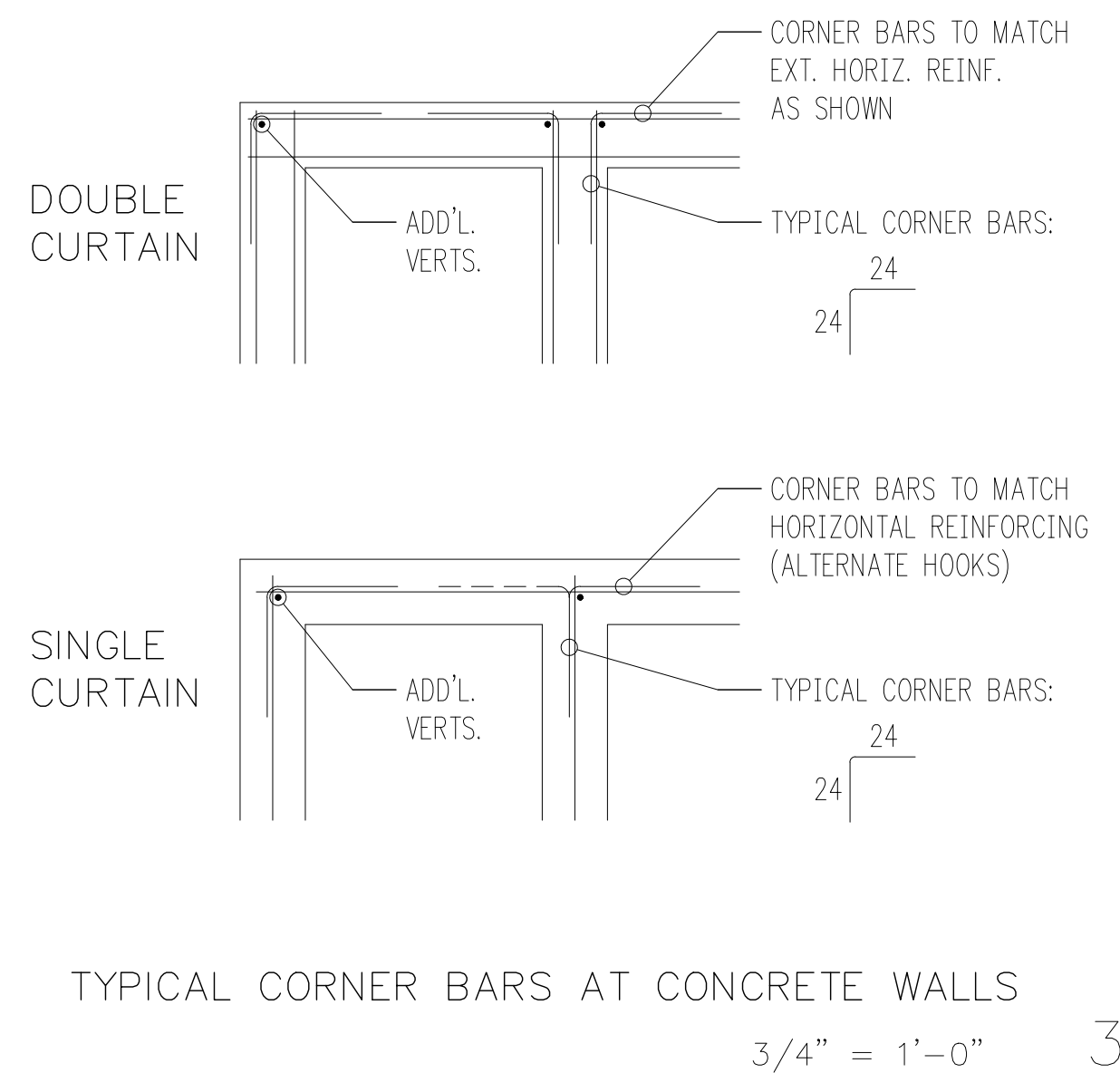
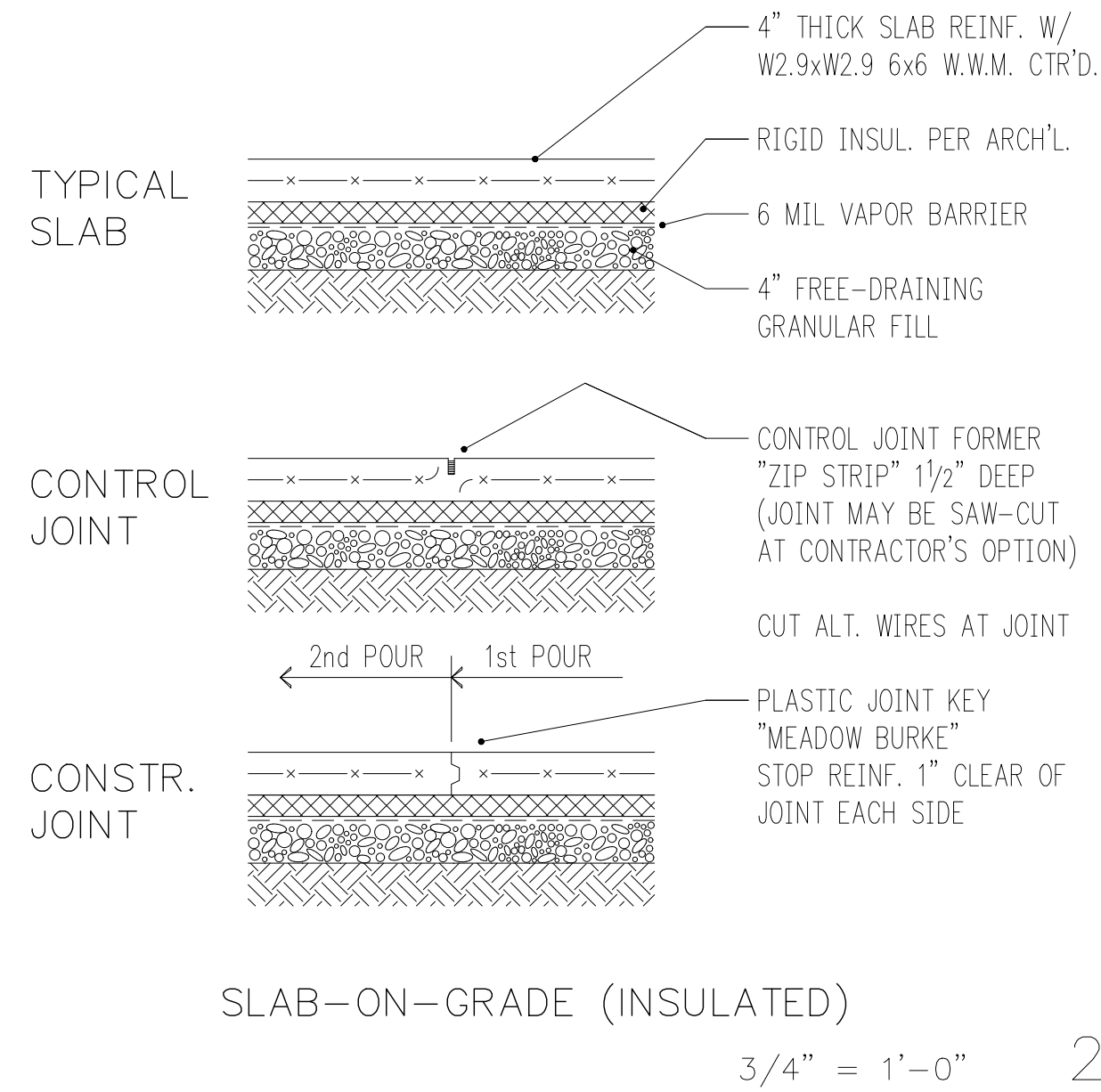

1 FIRST FLOOR FRAMING & LOWER FOUNDATION PLAN (BASEMENT WALLS)
 scale: 1/4" = 1'-0"

LEGEND

SPAN
 EXTENT
 SECTION DETAIL
 (FB) FLUSH BEAM
 (PT) PRESSURE-TREATED
 :: COLUMN ABOVE
 □ COLUMN BELOW
 NEW STRUCTURAL WALL
 NEW SHEARWALL
 NEW CONCRETE WALL
 ALL-THREAD HOLDOWN AT END OF SHEARWALL ABOVE
 STRAP HOLDOWN AT END OF SHEARWALL ABOVE

- PLAN NOTES**
- SW... INDICATES SHEARWALL TYPE PER SCHEDULE 8/S4.0. REFER TO DETAILS FOR TYPICAL SHEARWALL CONSTRUCTION. SEE ARCHITECTURAL DRAWINGS FOR ADDITIONAL WALL INFORMATION.
 - REFER TO GENERAL STRUCTURAL NOTES FOR FLOOR OR ROOF SHEATHING TYPE, THICKNESS, AND NAILING.
 - COLUMNS SHALL BE DOUBLE STUD MINIMUM, UNLESS NOTED OTHERWISE. SEE 11/S4.0.
 - AT ALL SHEARWALLS PROVIDE DOUBLE TOP PLATES AND SPLICE PER 12/S4.0.
 - CS... INDICATES COILED STRAP TYPE PER SCHEDULE 6/S4.0. REFER TO DETAILS FOR TYPICAL STRAP ASSEMBLY.
 - POSTS □, INCLUDING ENDS OF WALL OPENINGS, SHALL BE (2)2x6 UNLESS NOTED OTHERWISE.
 - SEE 10/S4.0 FOR TYPICAL HOLDOWN REQUIREMENTS AT CONCRETE WALLS AND FOOTINGS.
 - SLAB-ON-GRADE SHALL BE PLACED AND CURED FOR A MINIMUM OF SEVEN DAYS BEFORE RETAINING WALLS ARE BACKFILLED. SEE RETAINING WALL DETAILS FOR SPECIFIC CONFIGURATION.

HV
 Harriott Valentine Engineers Inc.
 1932 First Avenue, Suite 720
 Seattle, Washington 98101-2447
 tel 206 624 4760 fax 206 447 6971
 www.harriottvalentine.com



Project Contact
 Conrad Beymer
 tel 206 756 0391
 fax 206 447 6971
 cbeymer@harriottvalentine.com

Project Architect
 SHED Architecture & Design
 1404 S Jackson Street
 Seattle, WA 98144

Project
Sullivan Residence
 3024 69th Ave SE
 Mercer Island, WA 98040

Issue Date	Issue Description
01/20/2023	Permit
05/18/2023	Corrections
07/04/2023	Corrections

Building Department Approval

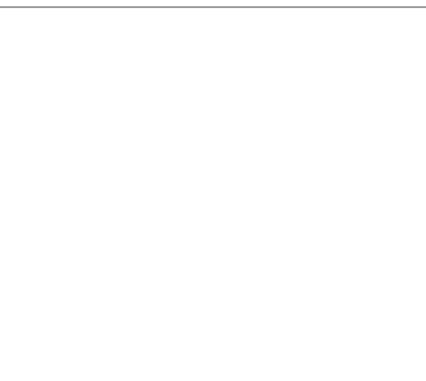

Drawing Title
MAIN FLOOR FRAMING PLAN

Drawing Number
S2.1

SULLIVAN RESIDENCE

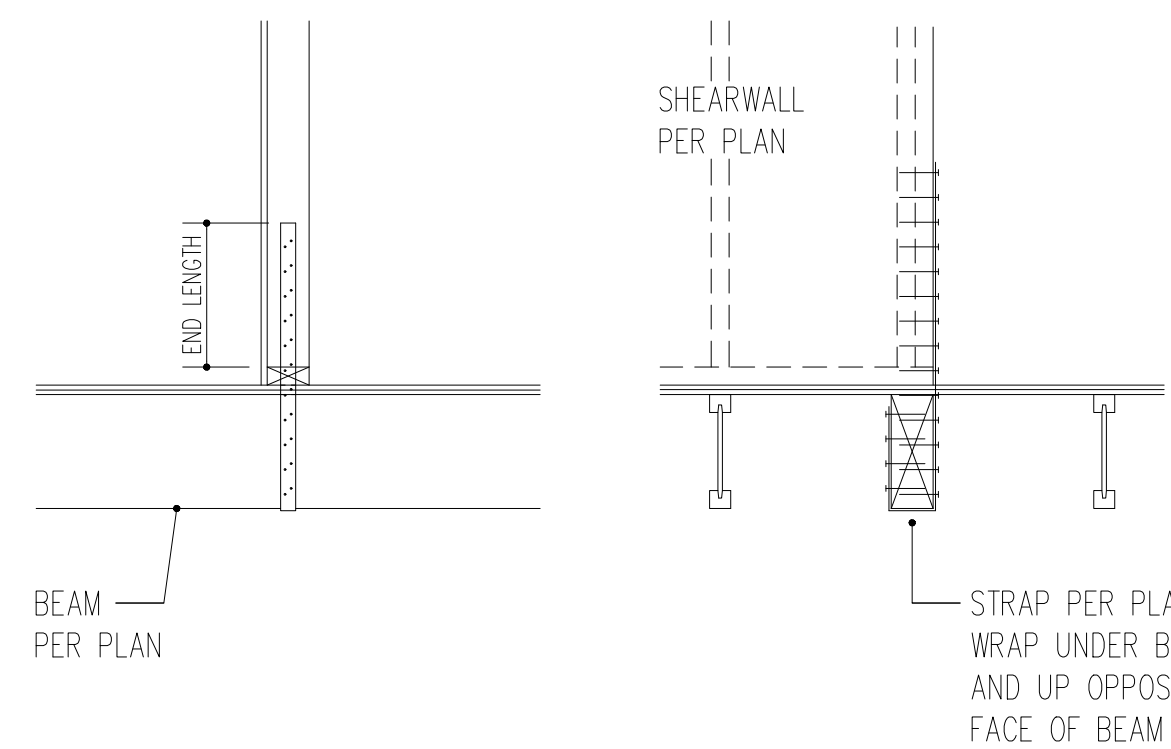
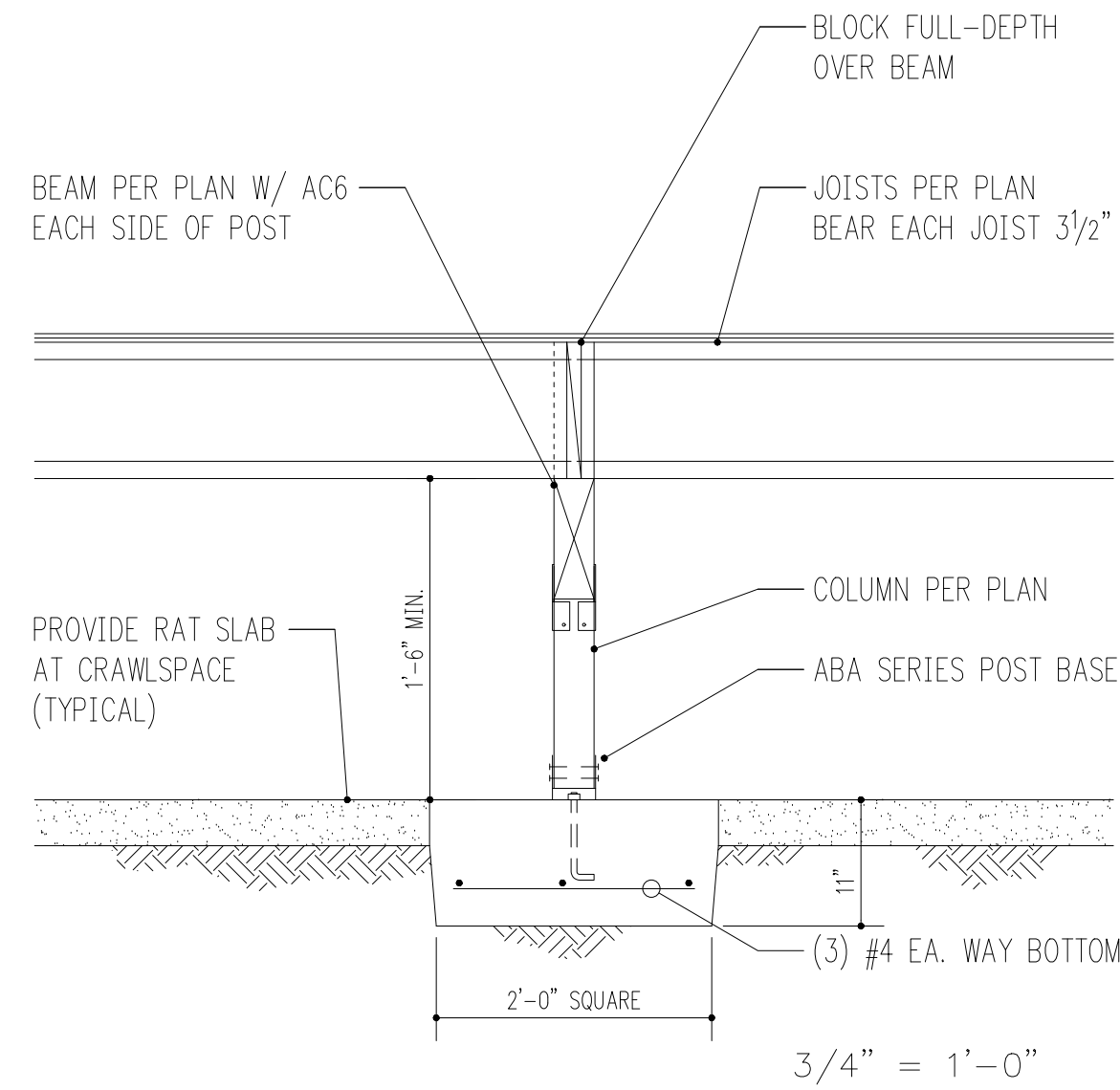

TYPICAL STRAP AT BEAM (PERPENDICULAR)

3/4" = 1'-0"

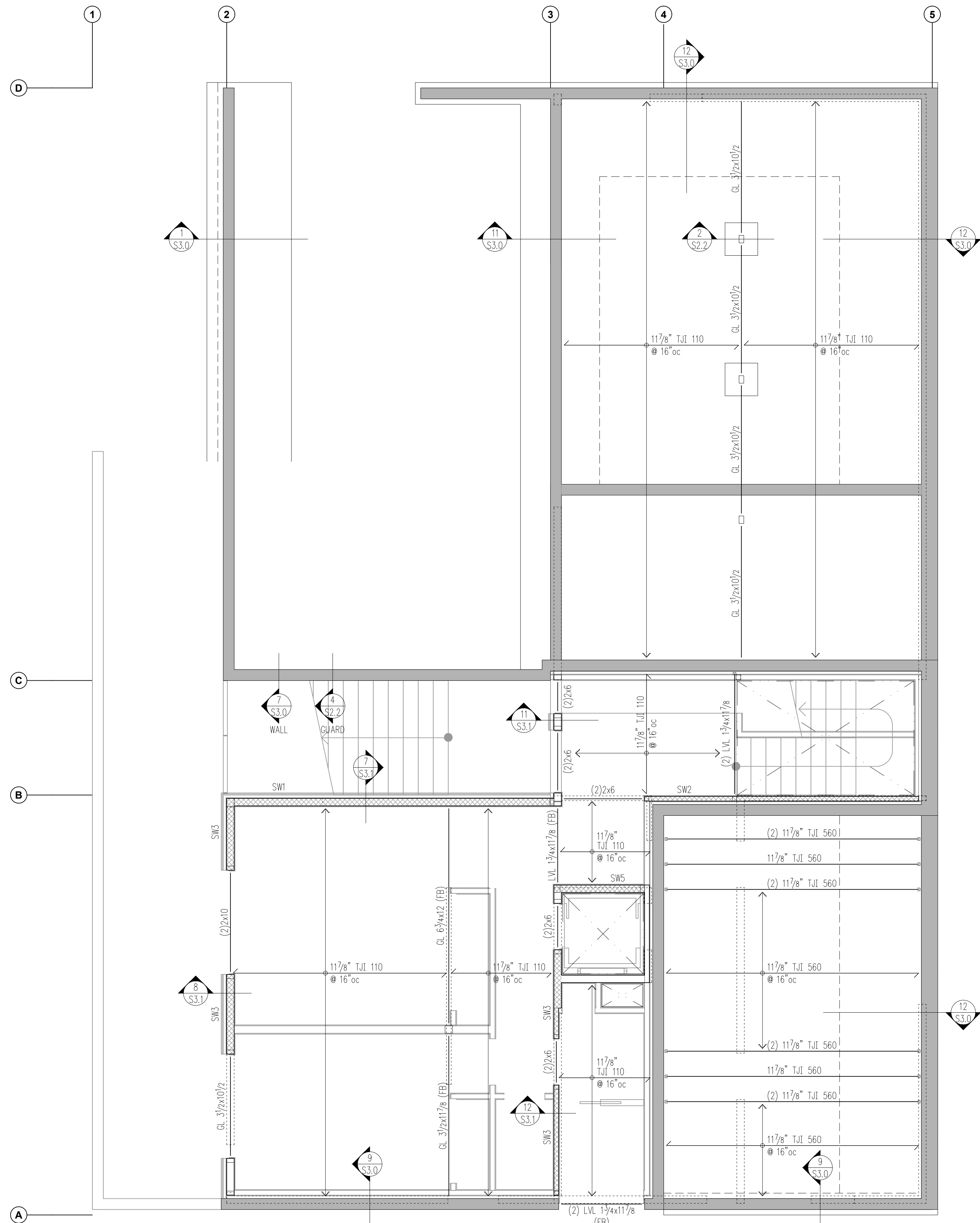
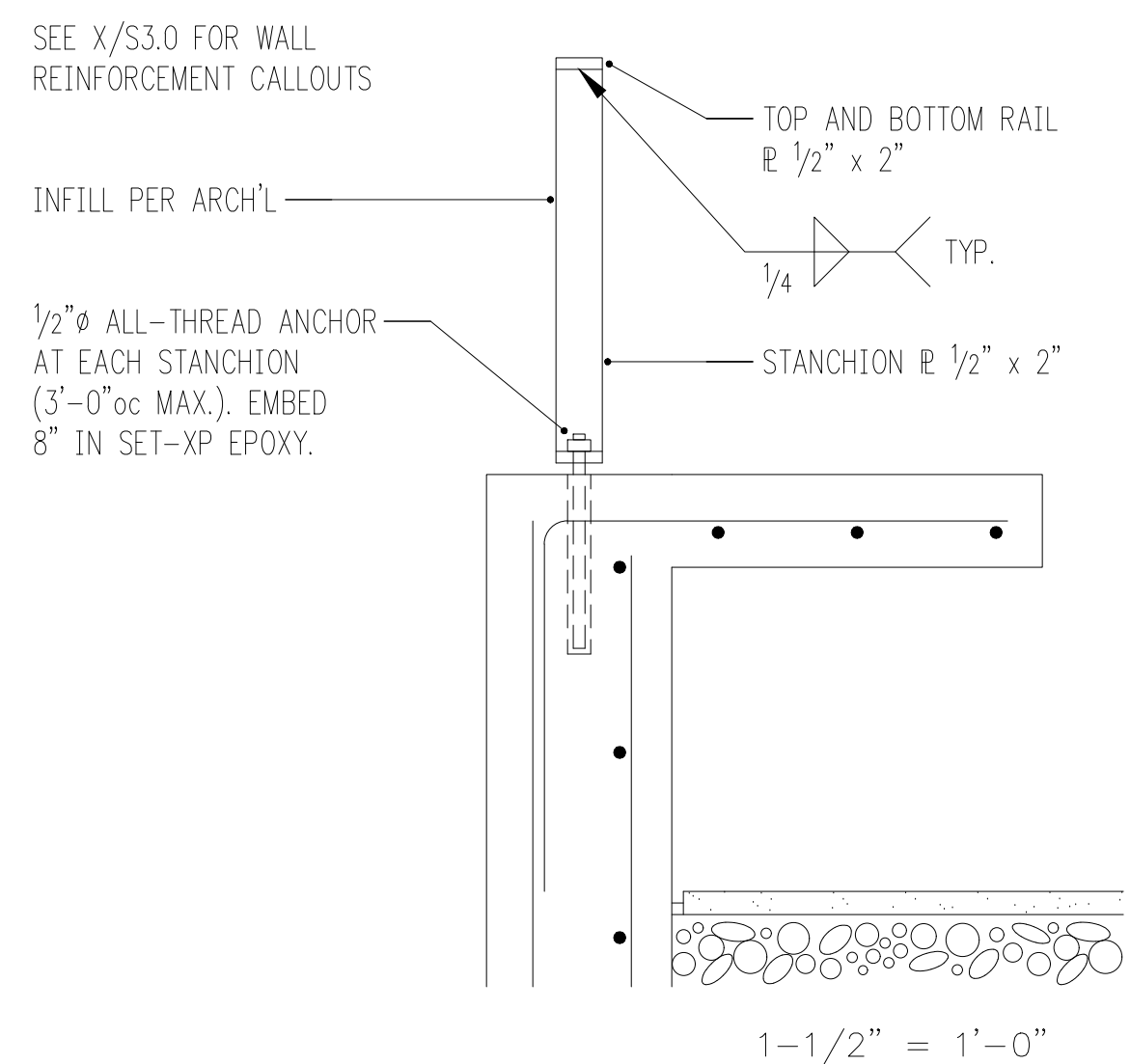

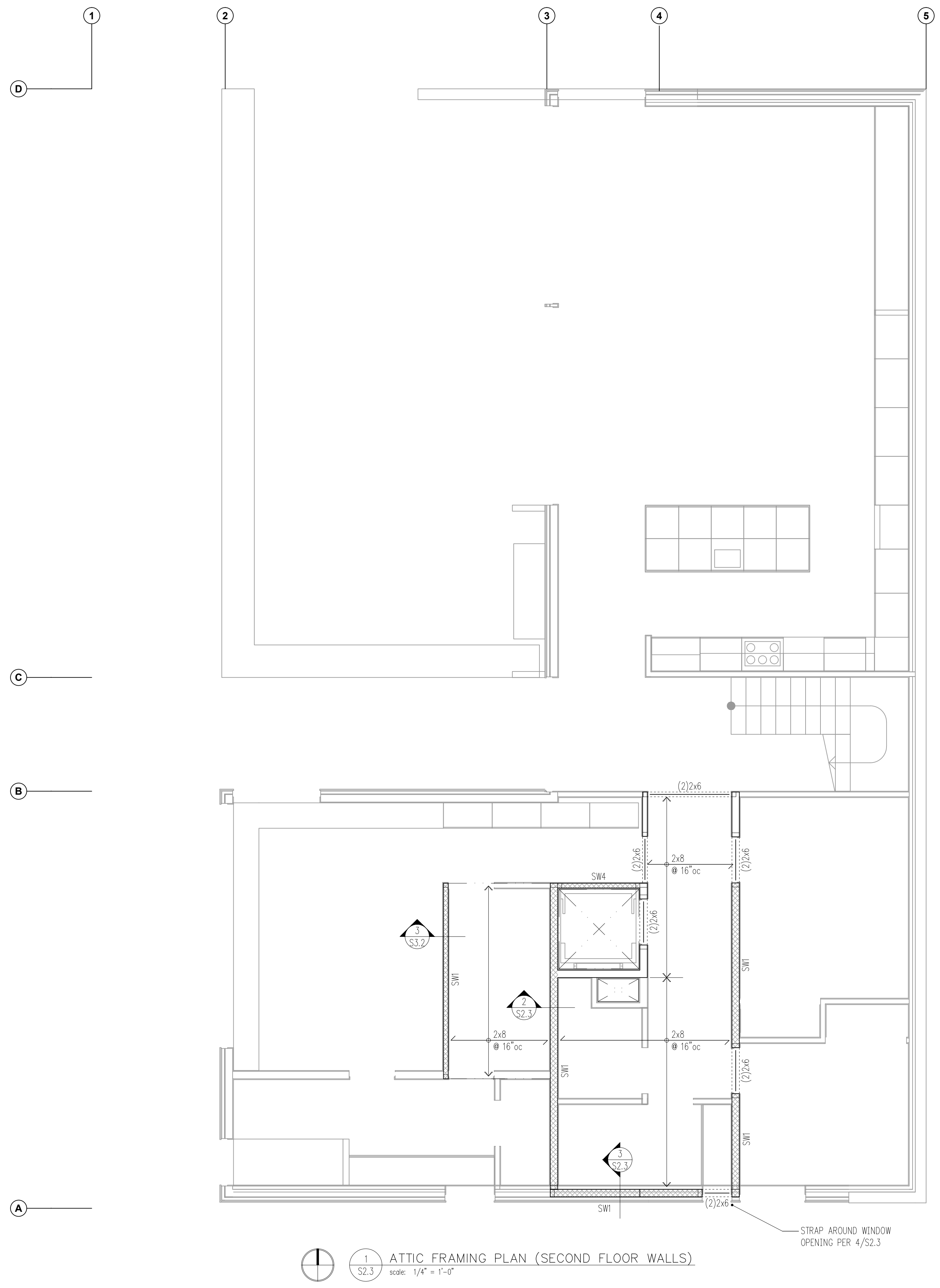
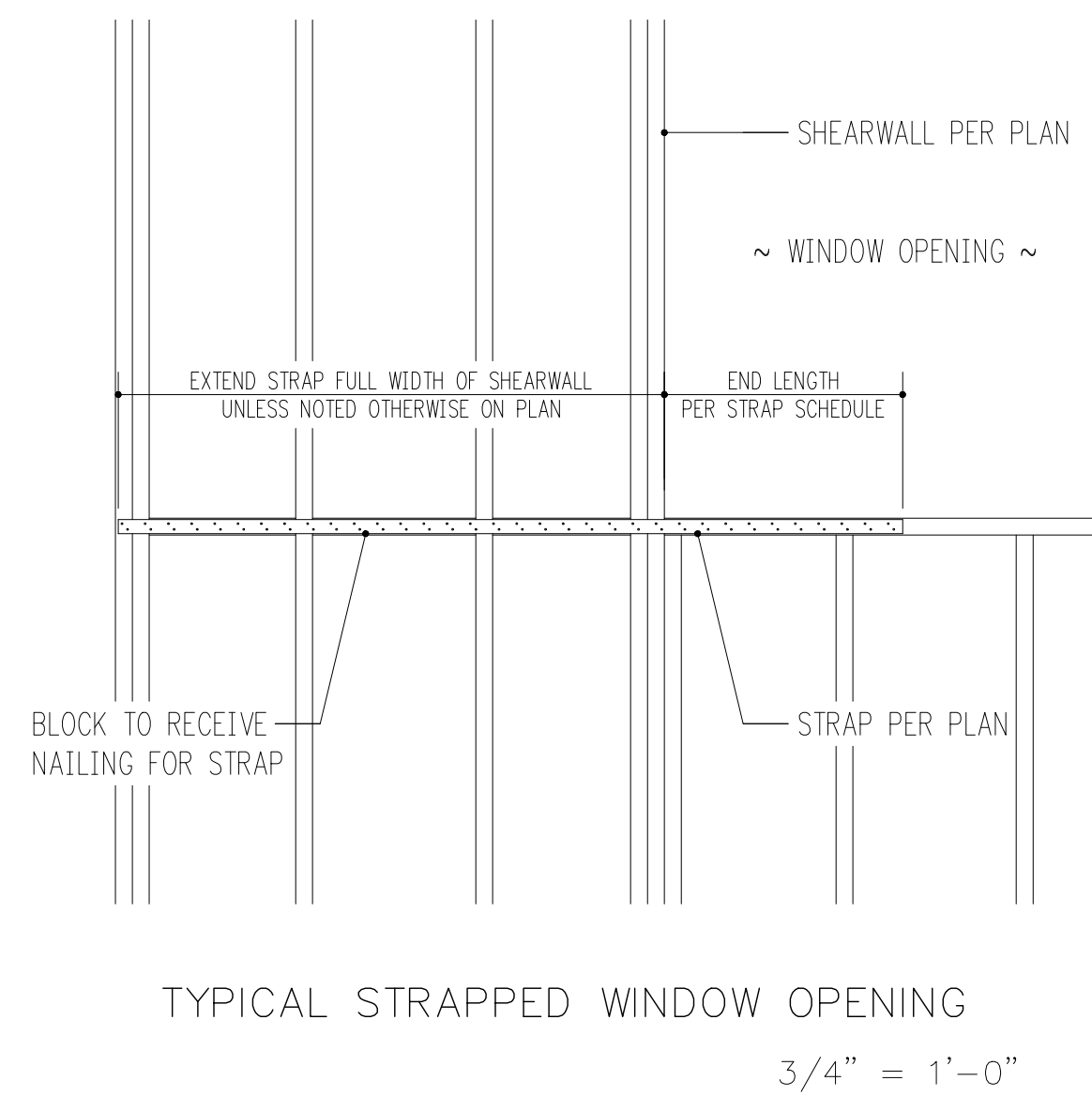
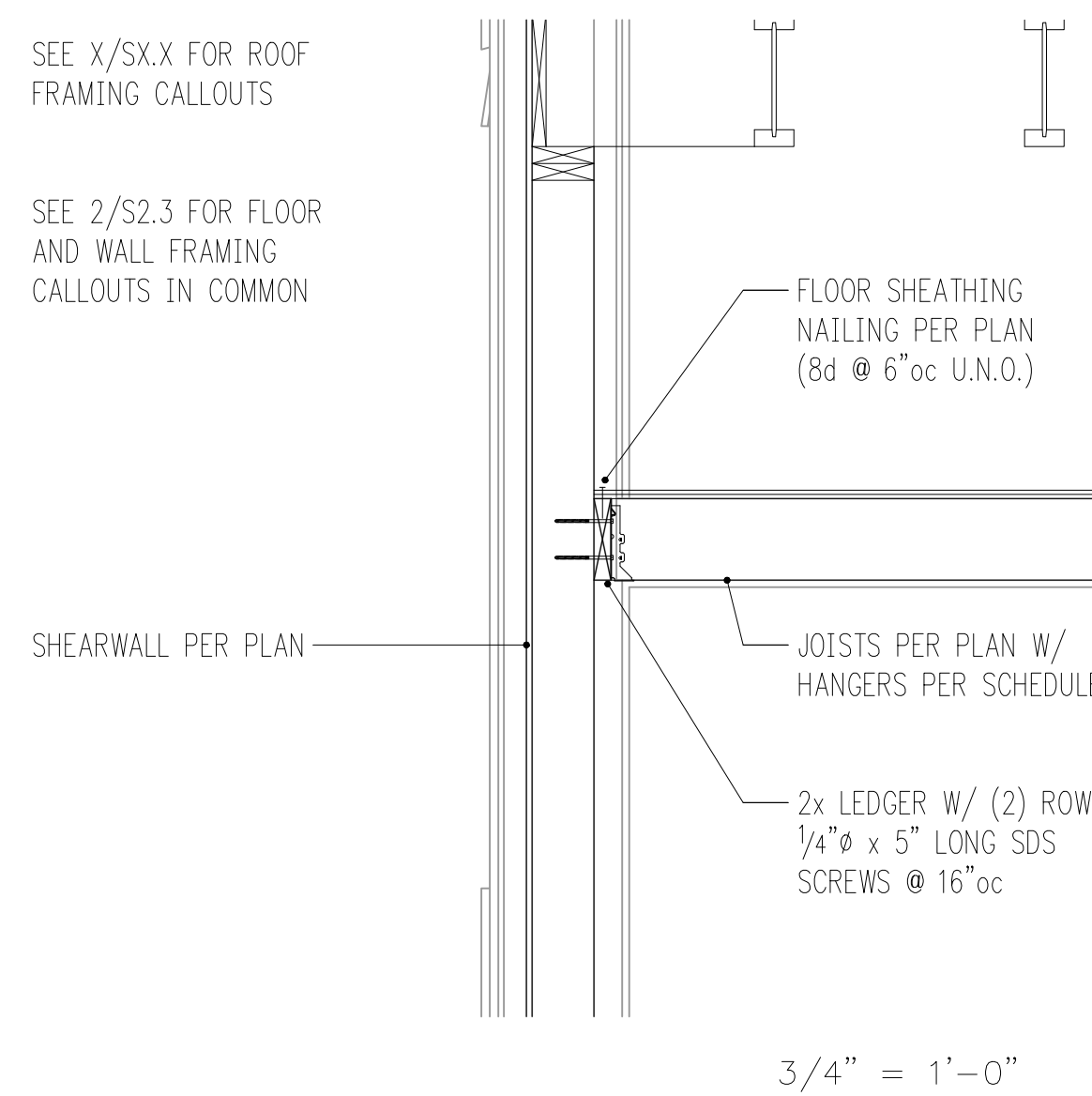
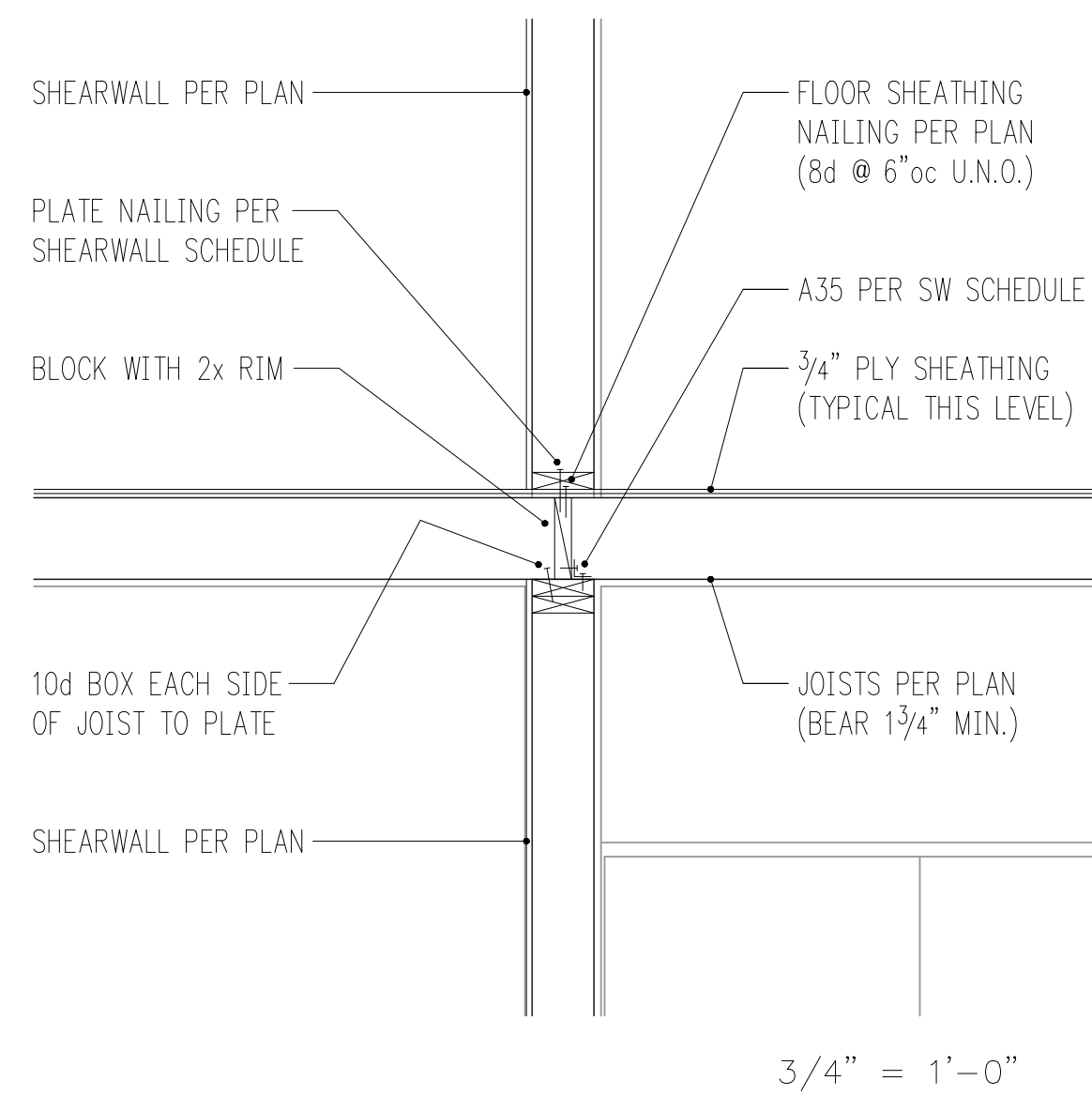

LEGEND

- SPAN
- EXTENT
- SECTION DETAIL
- (FB) FLUSH BEAM
- (PT) PRESSURE-TREATED
- :: COLUMN ABOVE
- COLUMN BELOW
- NEW STRUCTURAL WALL
- NEW SHEARWALL
- NEW CONCRETE WALL
- ALL-THREAD HOLDOWN AT END OF SHEARWALL ABOVE
- STRAP HOLDOWN AT END OF SHEARWALL ABOVE

- PLAN NOTES**
- SW___ INDICATES SHEARWALL TYPE PER SCHEDULE 8/S4.0. REFER TO DETAILS FOR TYPICAL SHEARWALL CONSTRUCTION. SEE ARCHITECTURAL DRAWINGS FOR ADDITIONAL WALL INFORMATION.
 - REFER TO GENERAL STRUCTURAL NOTES FOR FLOOR OR ROOF SHEATHING TYPE, THICKNESS, AND NAILING.
 - COLUMNS SHALL BE DOUBLE STUD MINIMUM, UNLESS NOTED OTHERWISE. SEE 11/S4.0.
 - AT ALL SHEARWALLS PROVIDE DOUBLE TOP PLATES AND SPLICE PER 12/S4.0.
 - CS___ INDICATES COILED STRAP TYPE PER SCHEDULE 6/S4.0. REFER TO DETAILS FOR TYPICAL STRAP ASSEMBLY.
 - POSTS □, INCLUDING ENDS OF WALL OPENINGS, SHALL BE (2)2x6 UNLESS NOTED OTHERWISE.

HANGER SCHEDULE

MEMBER (FLAT ONLY)	HANGER	FACE NAILING	CAPACITY (Cd = 1.0)
2x8	LUS28	10d COMMON	1055 lb
(2)2x6	LUS210	10d COMMON	1275 lb

1 ATTIC FRAMING PLAN (SECOND FLOOR WALLS)
 scale: 1/4" = 1'-0"

HV
 Harriott Valentine Engineers Inc.
 1932 First Avenue, Suite 720
 Seattle, Washington 98101-2447
 tel 206 624 4760 fax 206 447 6971
 www.harriottvalentine.com



Project Contact
 Conrad Beymer
 tel 206 756 0391
 fax 206 447 6971
 cbeymer@harriottvalentine.com

Project Architect
 SHED Architecture & Design
 1404 S Jackson Street
 Seattle, WA 98144

Project
Sullivan Residence
 3024 69th Ave SE
 Mercer Island, WA 98040

Issue Date	Issue Description
01/20/2023	Permit
05/18/2023	Corrections
07/04/2023	Corrections

Building Department Approval

Drawing Title
ROOF FRAMING PLAN

Drawing Number
S2.3

SULLIVAN RESIDENCE

STEEL BEAM PER PLAN
BLOCK WEB SOLID AND
ATTACH WITH 5/8"Ø
THRU-BOLTS @ 32"oc

WOOD TOP NAILER
ATTACHED WITH 5/8"Ø
THRU-BOLTS @ 32"oc

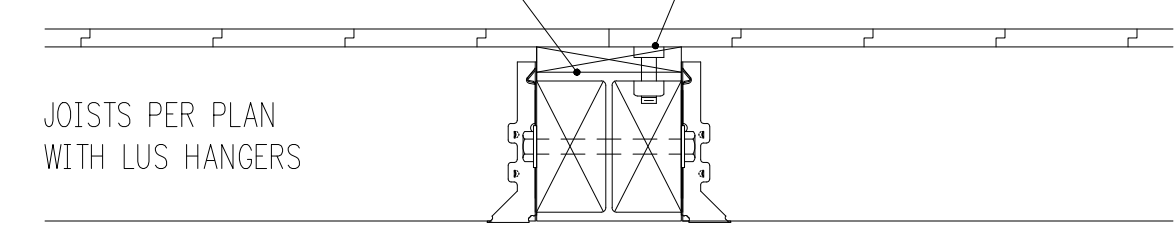

WF BEAM - JOISTS PERPENDICULAR

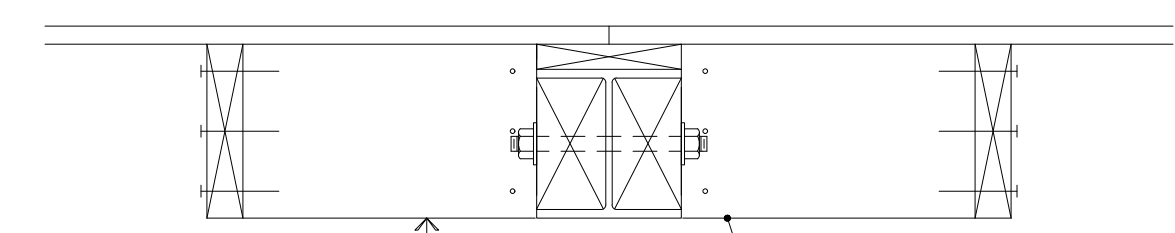

WF BEAM - JOISTS PARALLEL

3/4" = 1'-0" 1

SHEARWALL PER PLAN

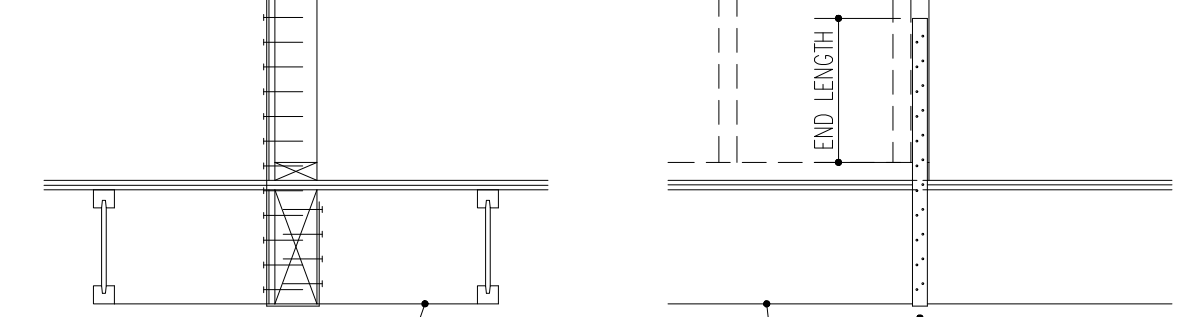

BLOCK ONE BAY EACH
SIDE FULL-DEPTH
@ 48"oc WITH LSL 1/4"
RIMBOARD - FIT TIGHT
TO TJI's

(SECTION)

TYPICAL STRAP AT BEAM (PARALLEL)

3/4" = 1'-0" 3

SHEARWALL PER PLAN

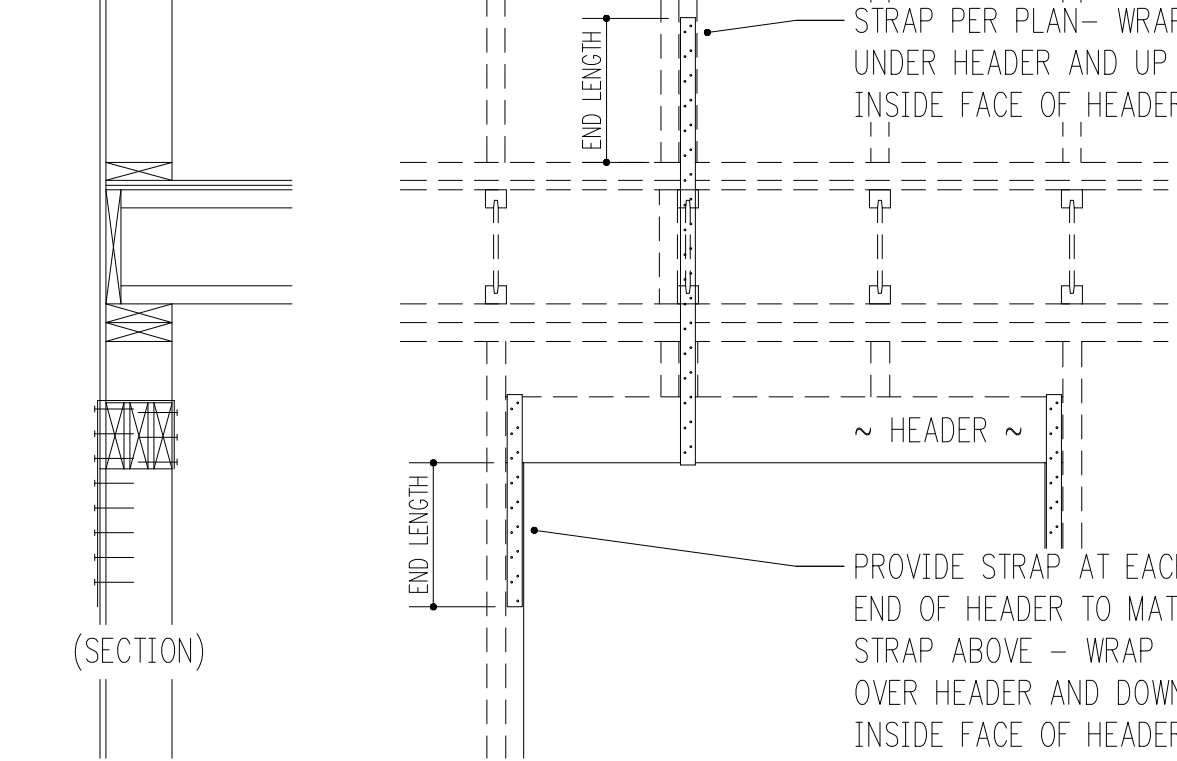

TYPICAL STRAPPED HEADER

3/4" = 1'-0" 4

A35 @ 48"oc

2x LEDGER WITH PANEL
EDGE NAILING PER PLAN
(8d @ 6"oc U.N.O.)

16d TO MATCH PANEL
EDGE NAILING SPACING

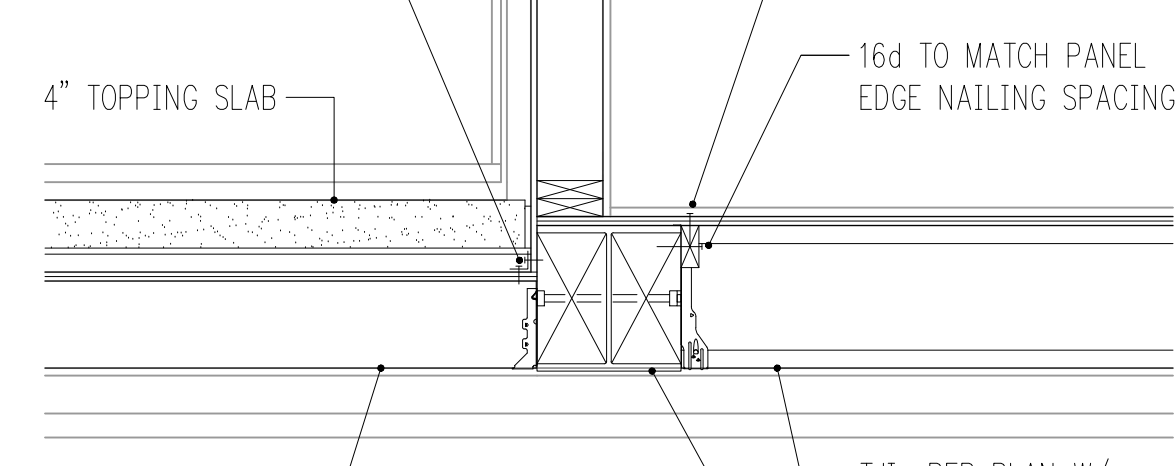

SEE 8/S3.0 FOR WALL
FRAMING CALLOUTS

3/4" = 1'-0" 5

SHEARWALL PER PLAN

TRIM TONGUES AND/OR
GROOVES AT EDGE OF
SHEATHING

(3) 10d BOX EACH
SIDE OF BLOCKING

1/4" LSL RIM
(U.N.O. ON PLAN)

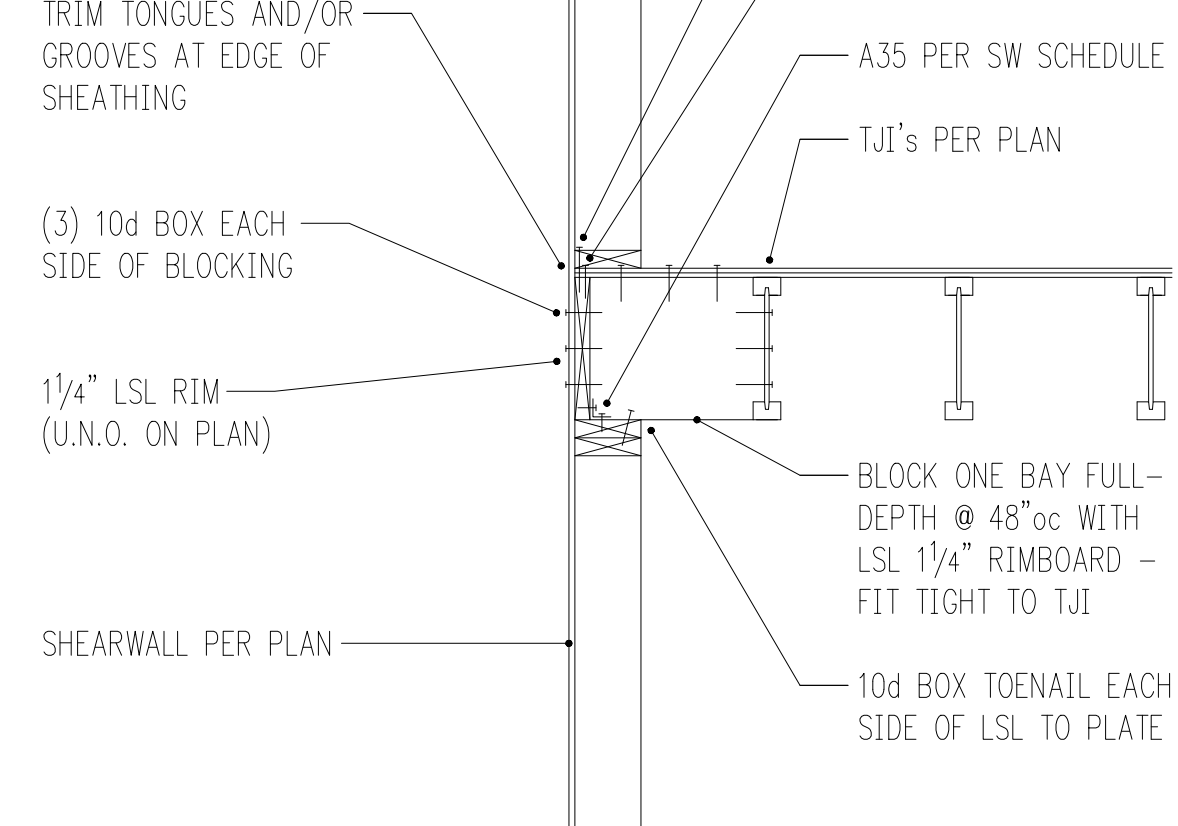

3/4" = 1'-0" 7

SHEARWALL PER PLAN

TRIM TONGUES AND/OR
GROOVES AT EDGE OF
SHEATHING

10d BOX FACENAIL
AT TOP AND BOTTOM
TJI FLANGES

1/4" LSL RIM
(U.N.O. ON PLAN)

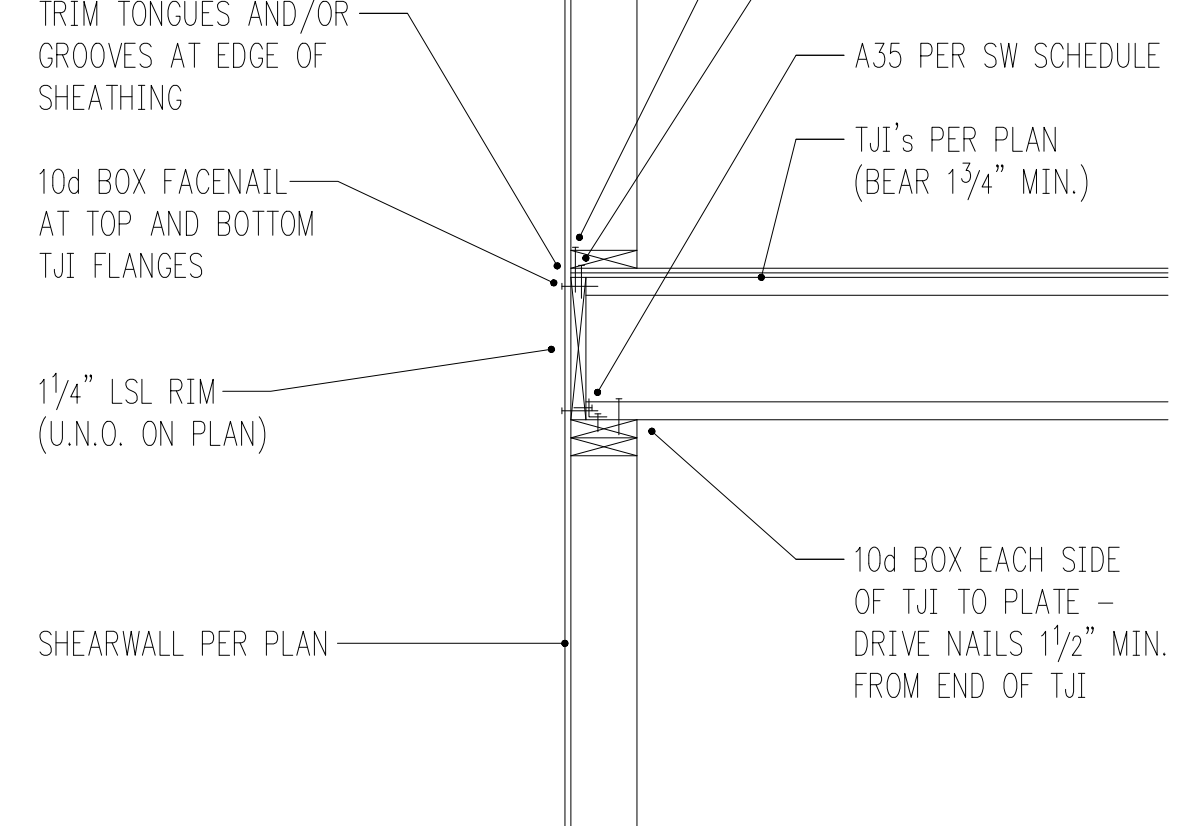

3/4" = 1'-0" 8

#4 @ 16"oc VERT.

#4 @ 10"oc HORIZ.

(6) #5 CONT. TOP
(LAP 24" MIN.)

#3 x 245' TIES @ 6"oc

#3 x 245' TIES @ 12"oc

(6) #5 CONT. BOTTOM
(LAP 24" MIN.)

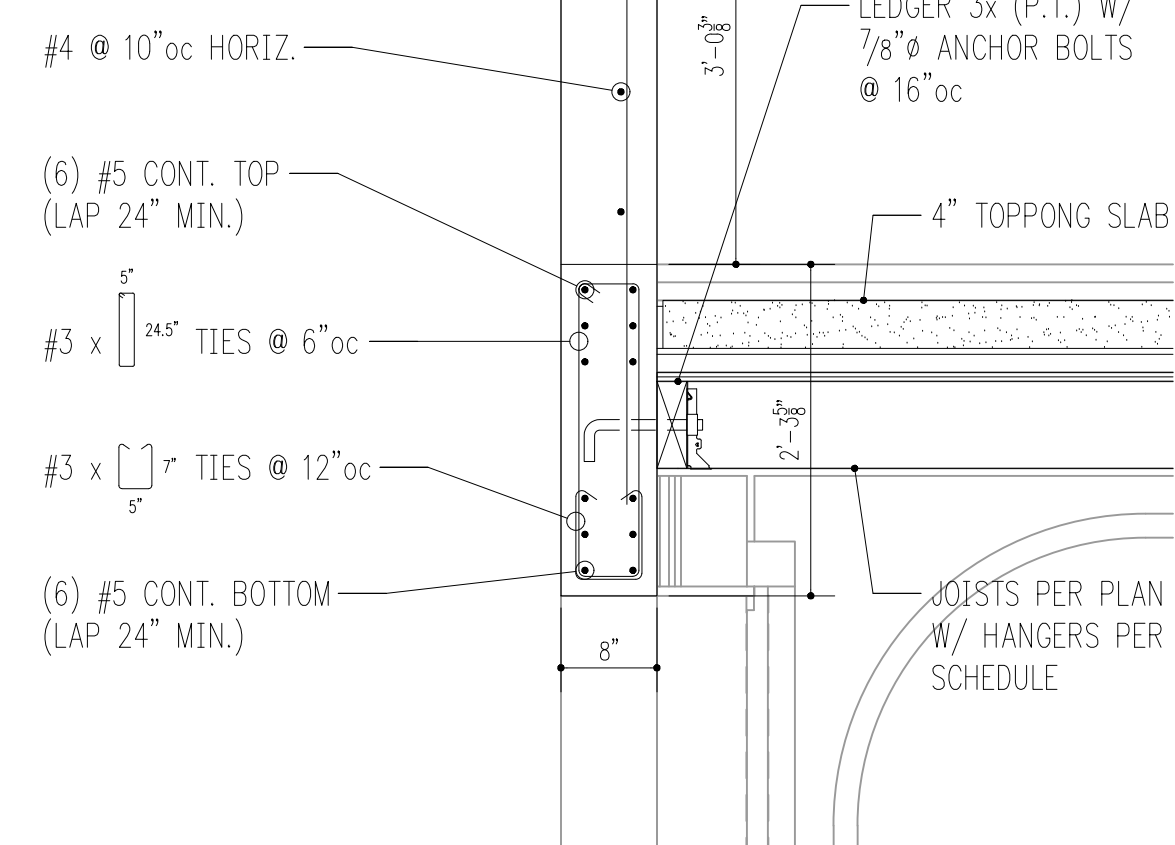

3/4" = 1'-0" 9

SHEARWALL PER PLAN

PROVIDE CONTINUOUS
LSL 1/4" OVER SW

(3) 10d BOX EACH
SIDE OF BLOCKING

A35 PER SW SCHEDULE

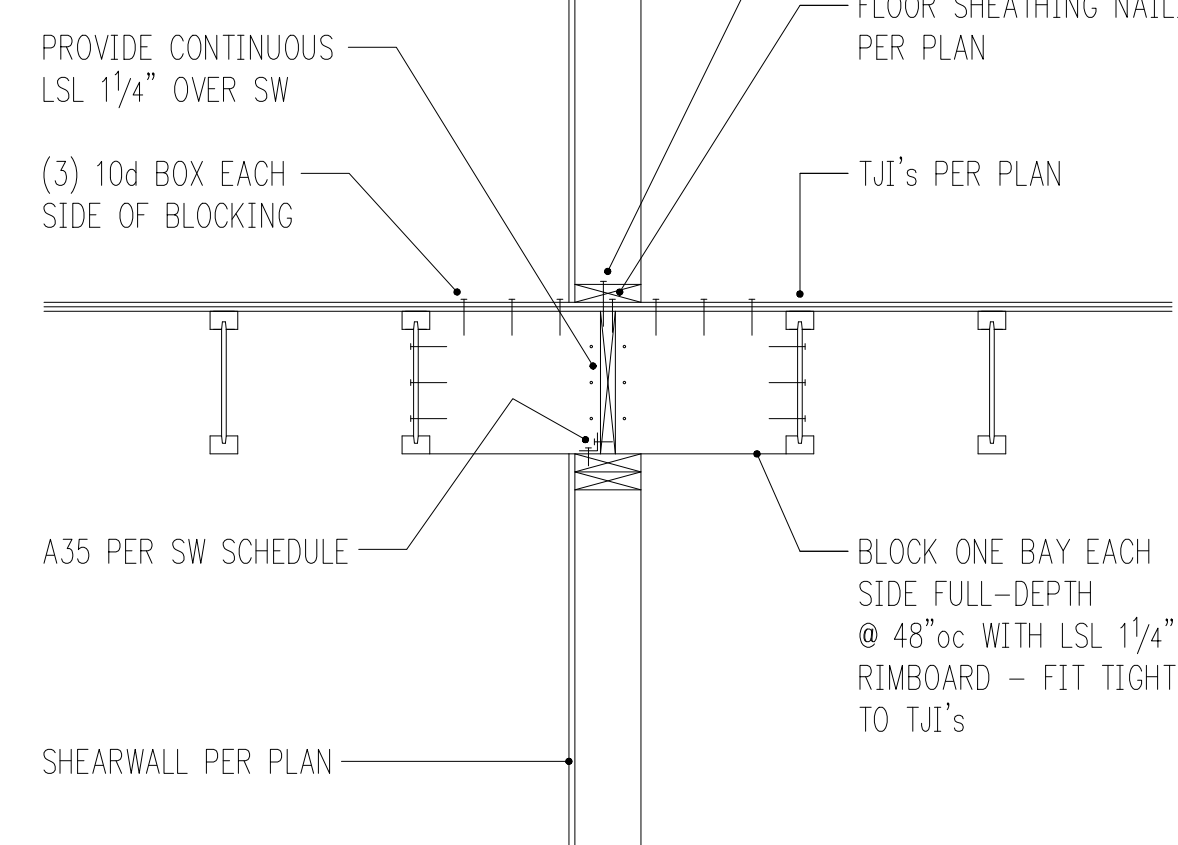

3/4" = 1'-0" 11

SHEARWALL PER PLAN

BLOCK WITH 1/4" LSL
RIM BOARD

10d BOX EACH SIDE
OF TJI TO PLATE

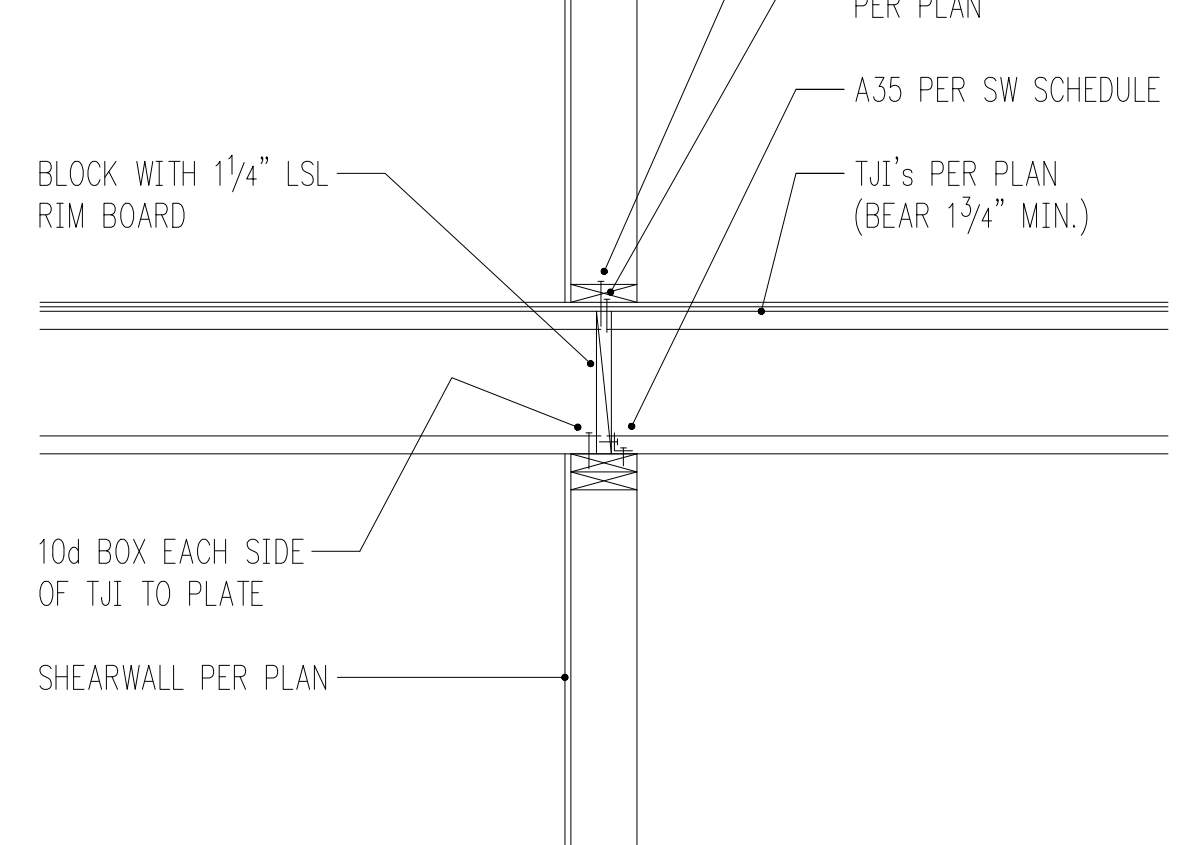

3/4" = 1'-0" 12

HV
Harriott Valentine Engineers Inc.
1932 First Avenue, Suite 720
Seattle, Washington 98101-2447
tel 206 624 4760 fax 206 447 6971
www.harriottvalentine.com



Project Contact
Conrad Beymer
tel 206 756 0391
fax 206 447 6971
cbeymer@harriottvalentine.com

Project Architect
SHED Architecture & Design
1404 S Jackson Street
Seattle, WA 98144

Project
Sullivan Residence
3024 69th Ave SE
Mercer Island, WA 98040

Issue Date	Issue Description
01/20/2023	Permit
05/18/2023	Corrections
07/04/2023	Corrections

Building Department Approval

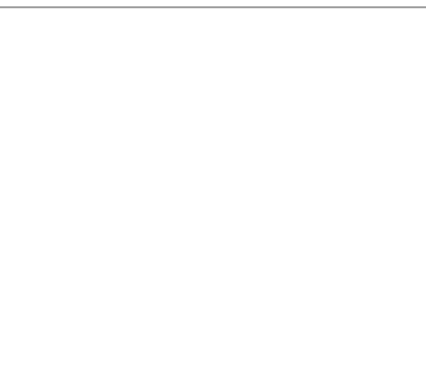

Drawing Title
STRUCTURAL DETAILS

Drawing Number
S3.1

SULLIVAN RESIDENCE



3/4" = 1'-0" 1

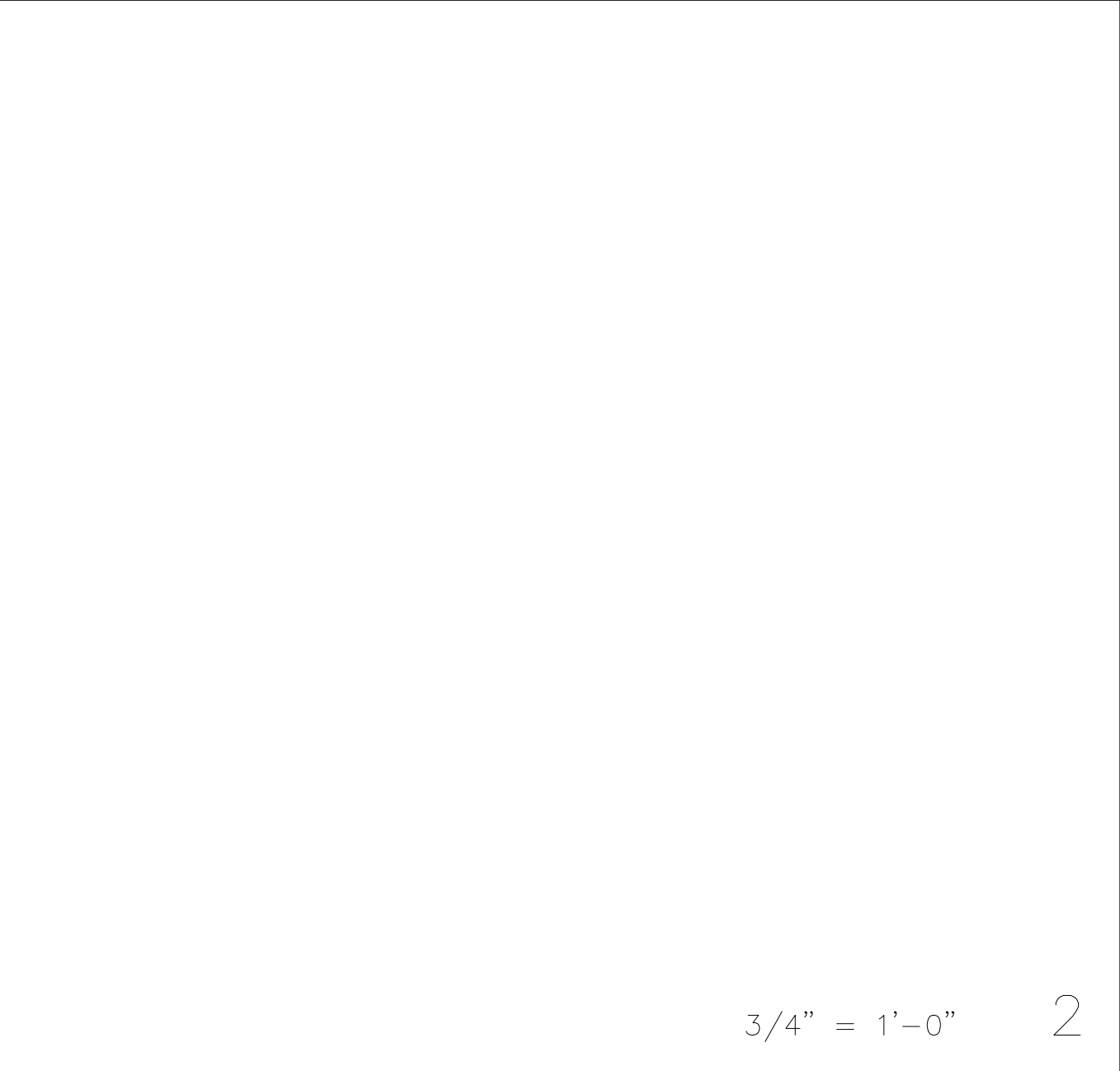

3/4" = 1'-0" 2

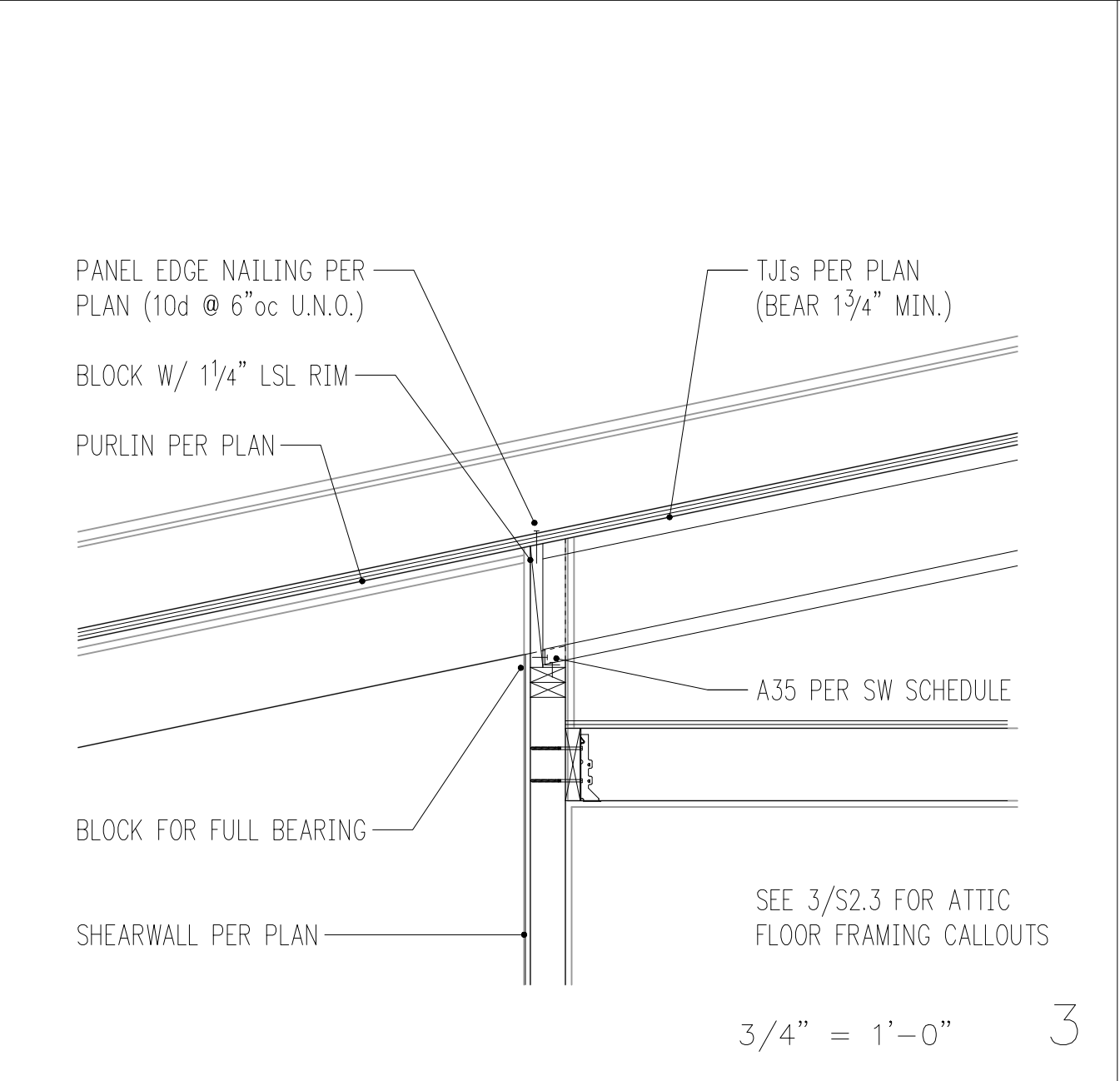

3/4" = 1'-0" 3

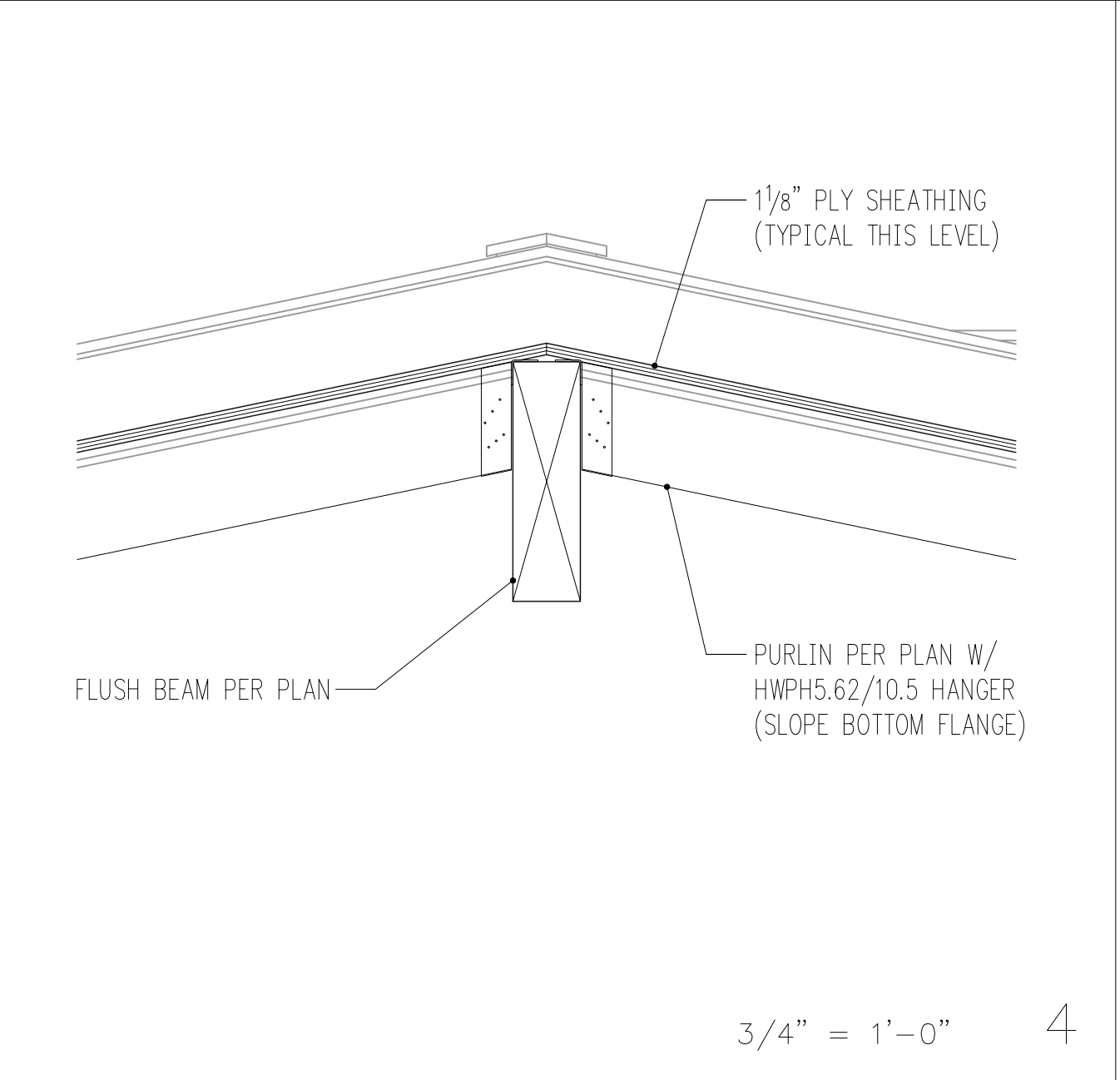

3/4" = 1'-0" 4

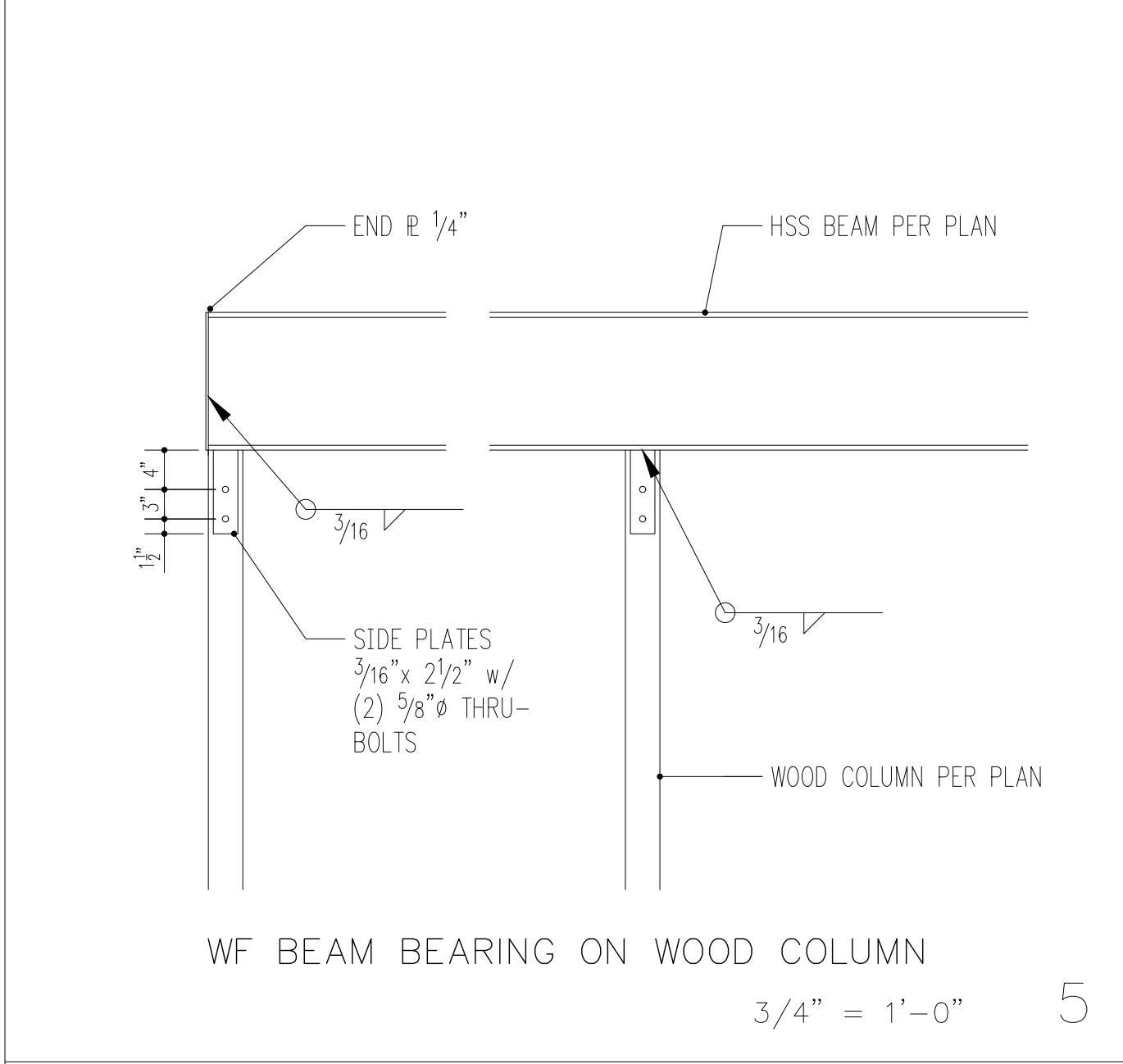

3/4" = 1'-0" 5

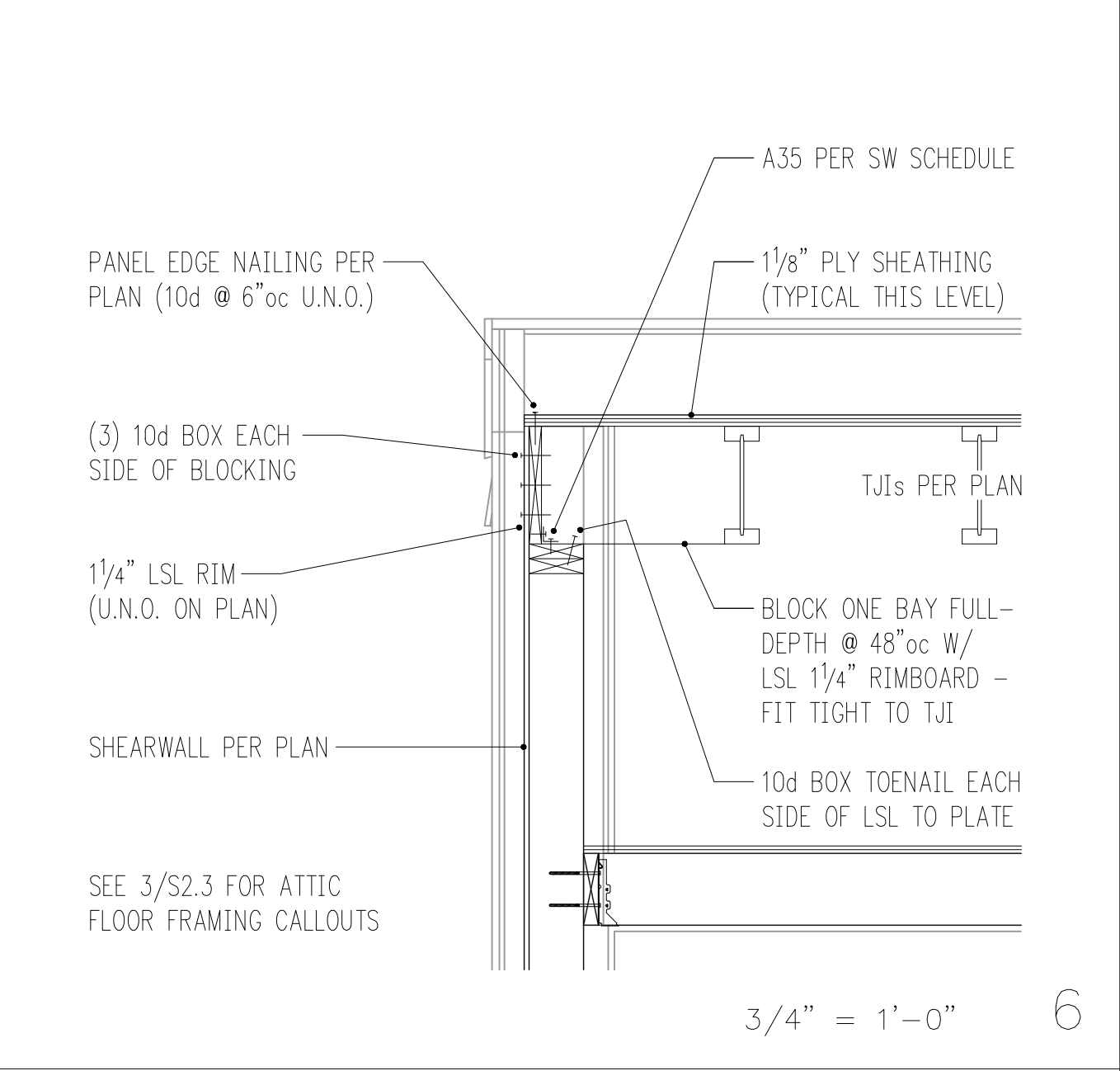

3/4" = 1'-0" 6

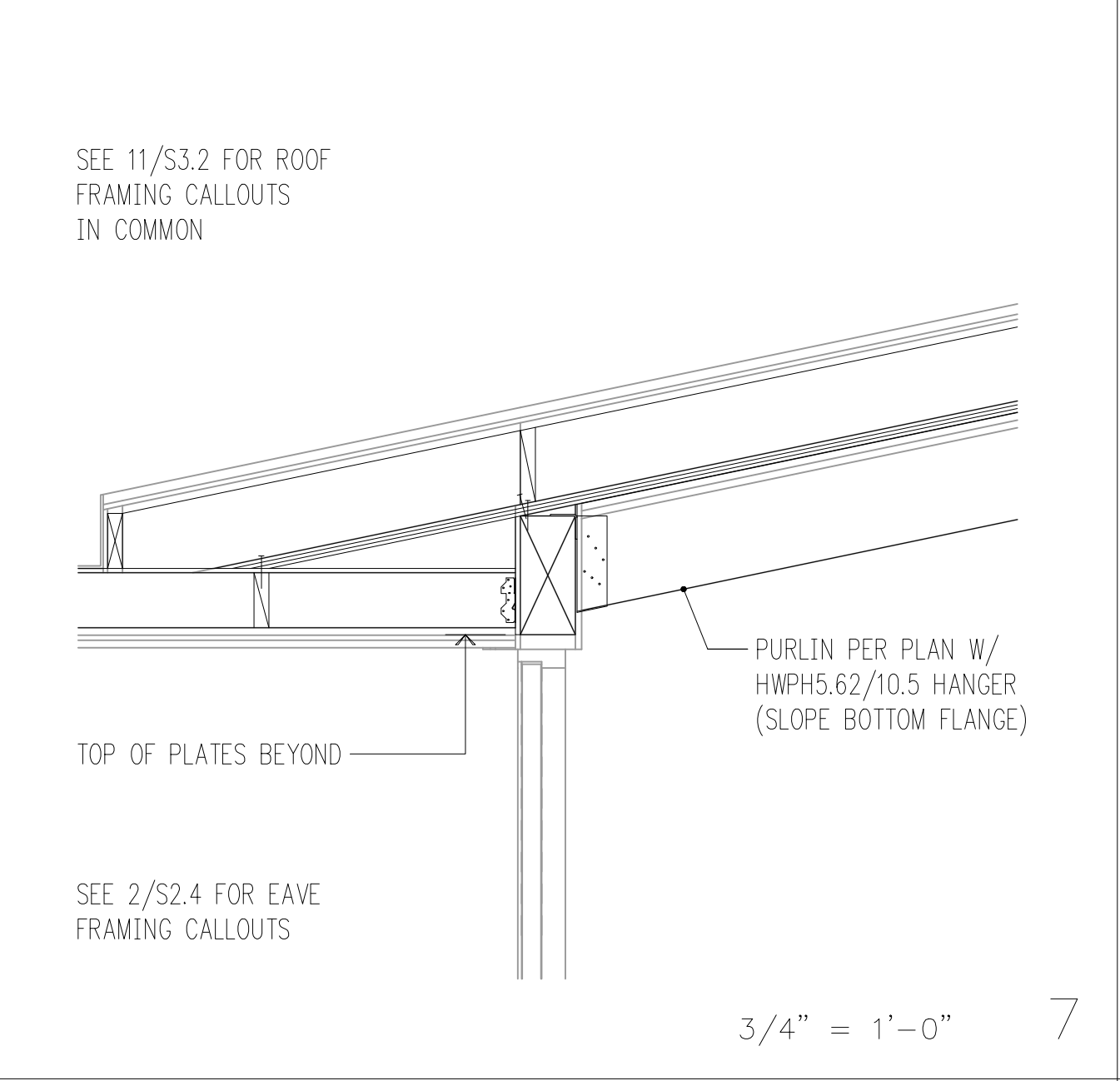

3/4" = 1'-0" 7

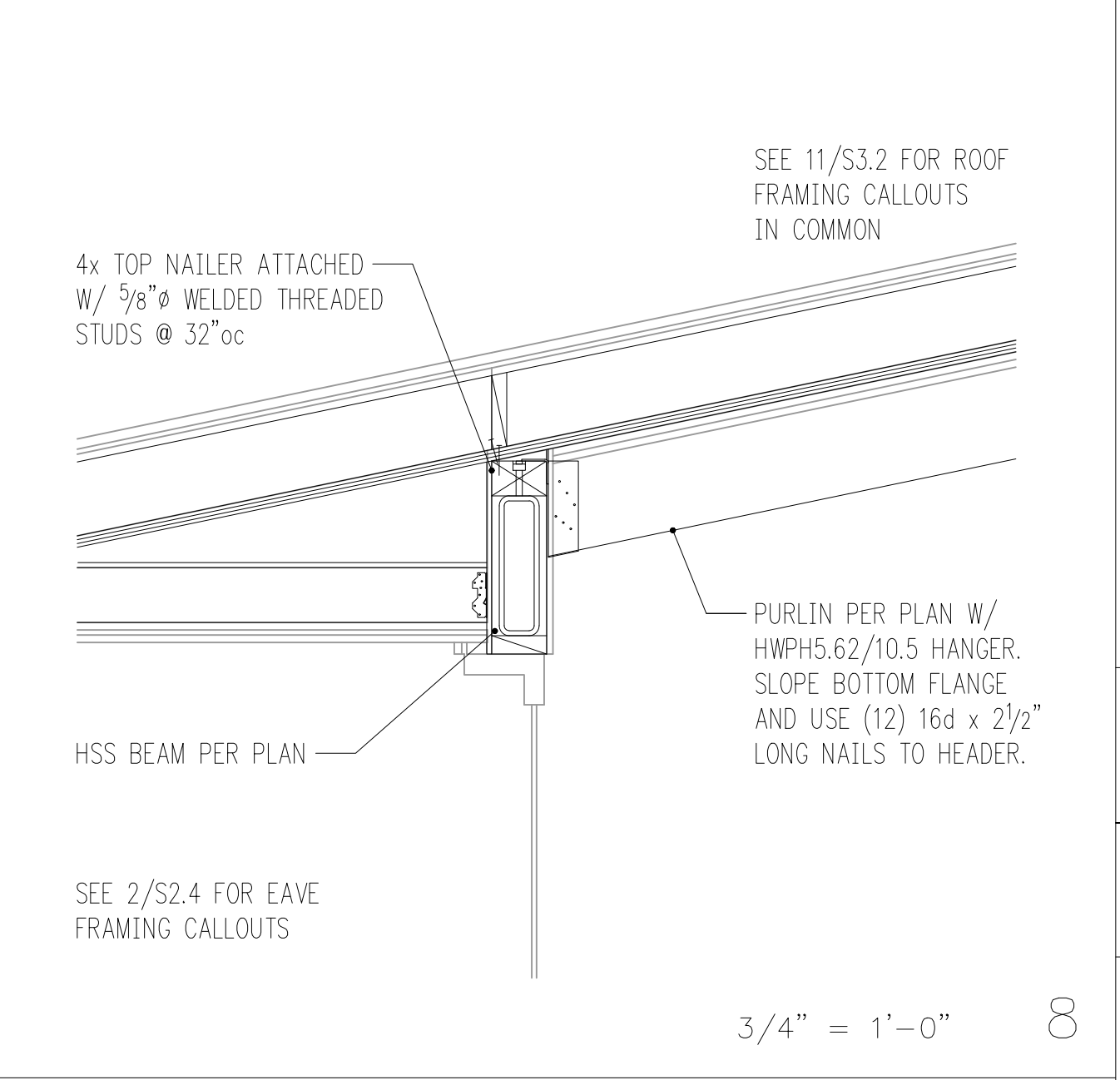

3/4" = 1'-0" 8

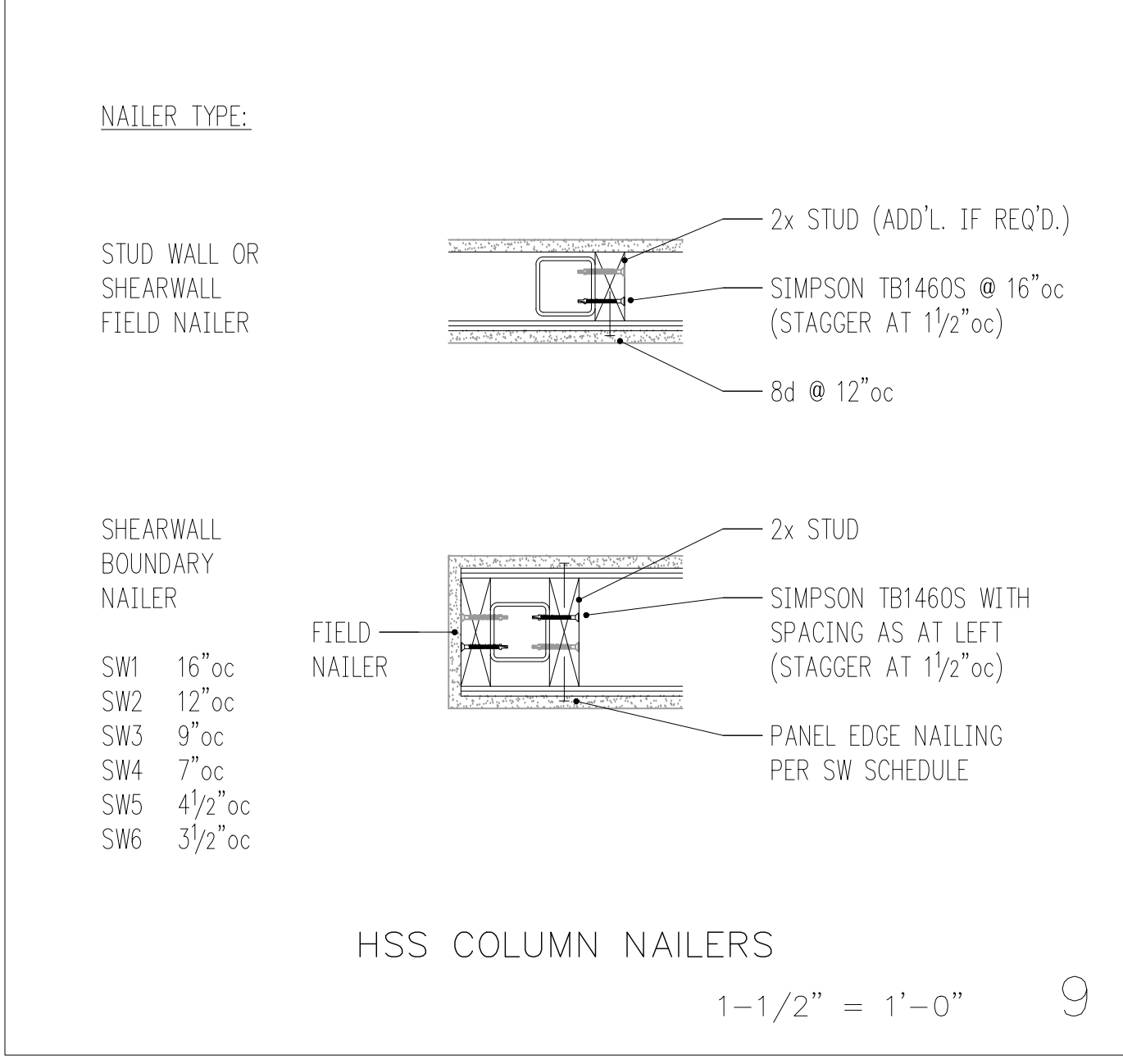

1-1/2" = 1'-0" 9

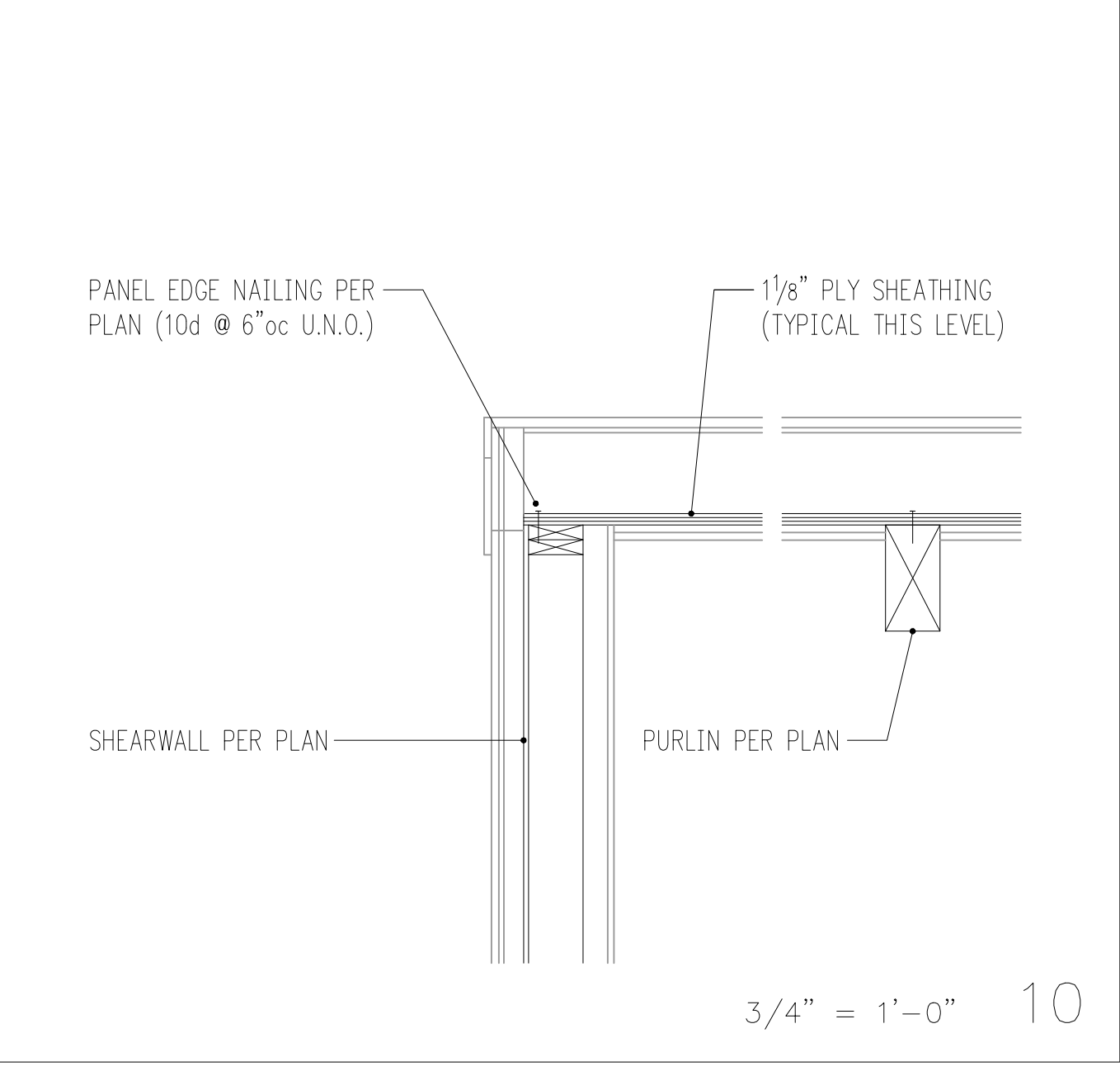

3/4" = 1'-0" 10

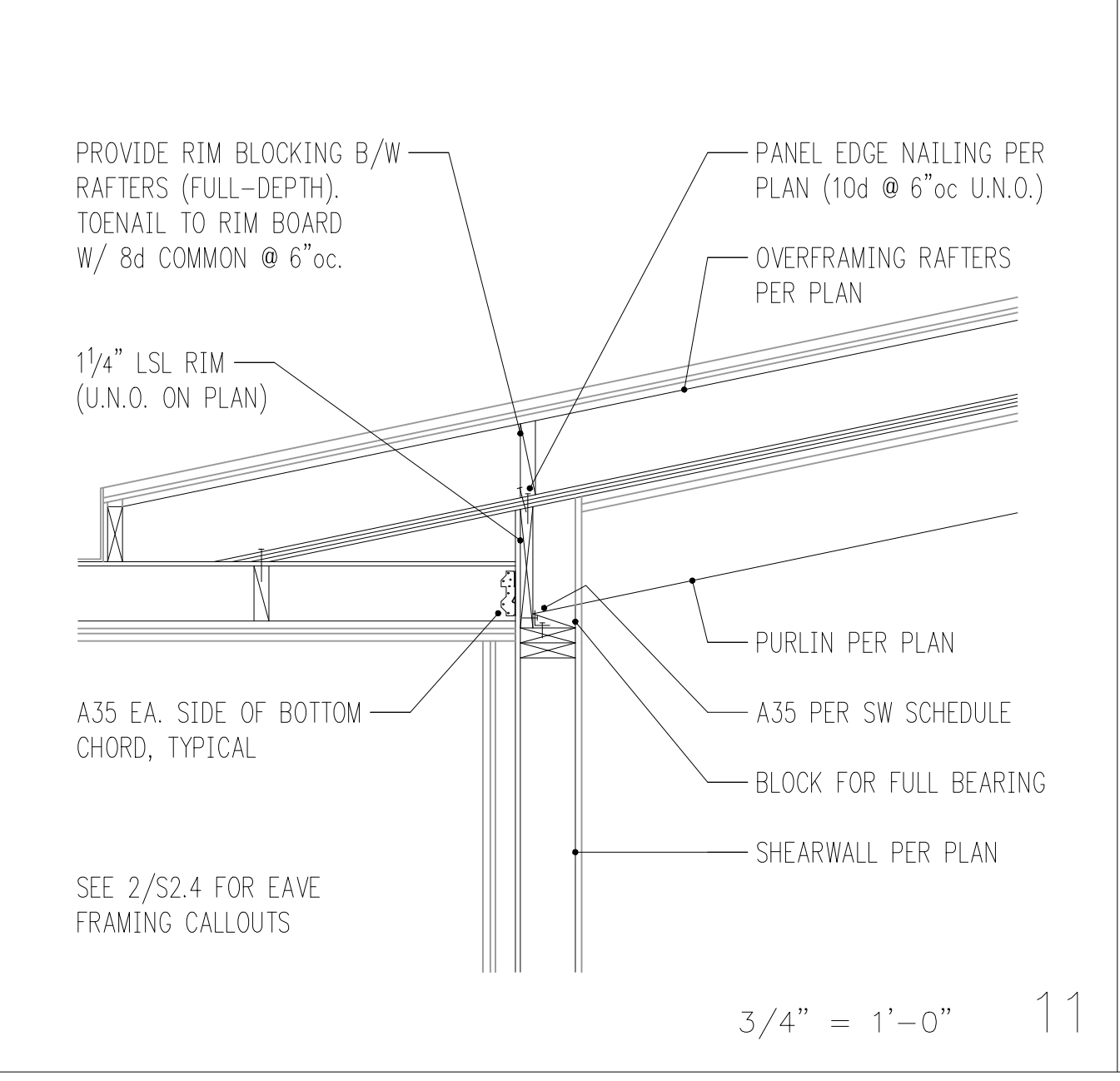

3/4" = 1'-0" 11

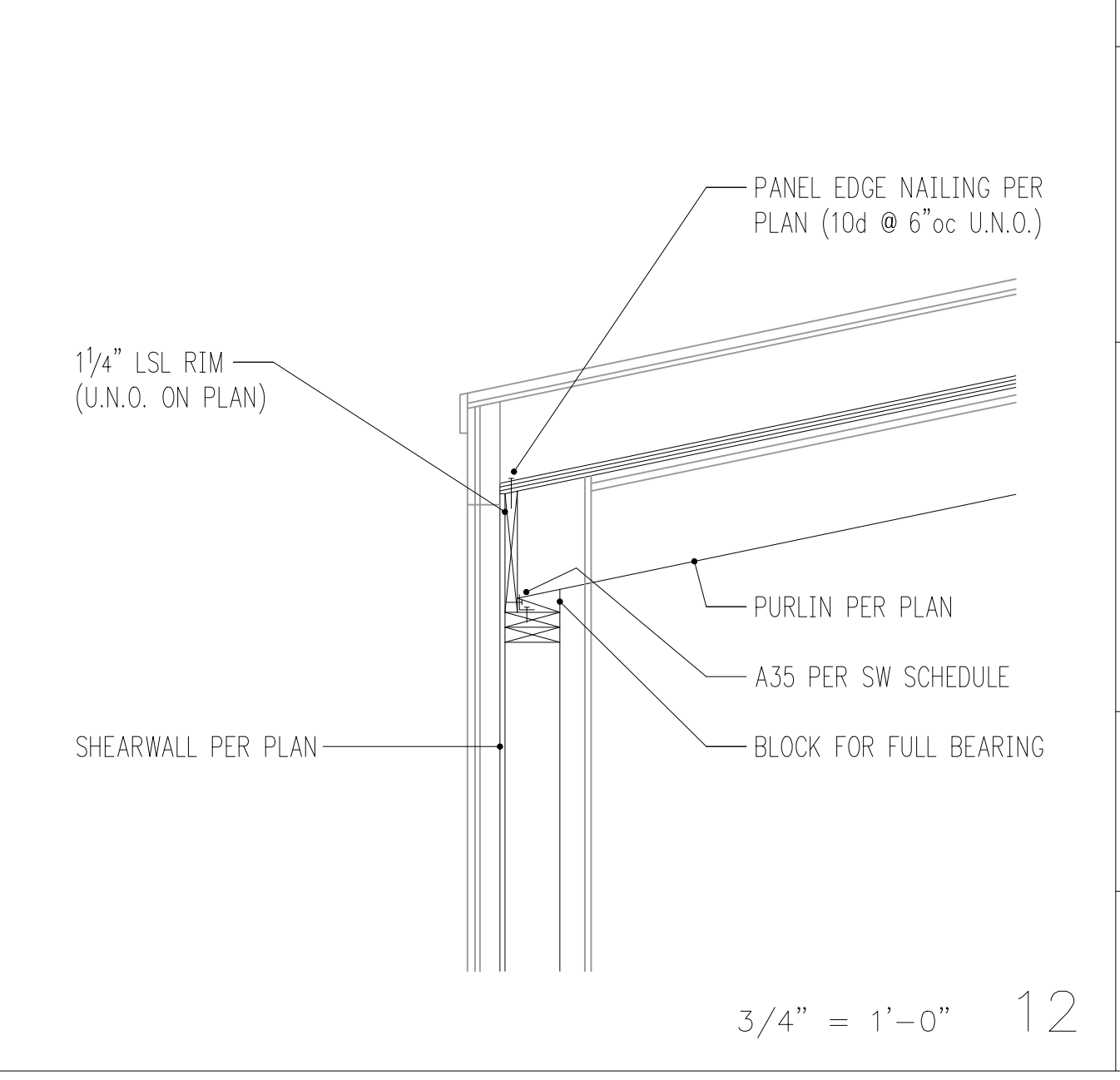

3/4" = 1'-0" 12

HV
Harriott Valentine Engineers Inc.
 1932 First Avenue, Suite 720
 Seattle, Washington 98101-2447
 tel 206 624 4760 fax 206 447 6971
 www.harriottvalentine.com



Project Contact
 Conrad Beymer
 tel 206 756 0391
 fax 206 447 6971
 cbeymer@harriottvalentine.com

Project Architect
 SHED Architecture & Design
 1404 S Jackson Street
 Seattle, WA 98144

Project
Sullivan Residence
 3024 69th Ave SE
 Mercer Island, WA 98040

Issue Date	Issue Description
01/20/2023	Permit
05/18/2023	Corrections
07/04/2023	Corrections

Building Department Approval

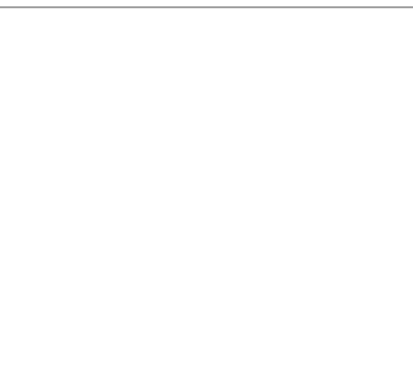

Drawing Title
STRUCTURAL DETAILS

Drawing Number
S3.2

SULLIVAN RESIDENCE

TEMPORARY SHORING GENERAL NOTES
(THE FOLLOWING APPLY UNLESS SHOWN OTHERWISE ON THE PLANS)

CRITERIA

1. ALL MATERIALS, WORKMANSHIP, DESIGN, AND CONSTRUCTION SHALL CONFORM TO THE DRAWINGS, SPECIFICATIONS, THE INTERNATIONAL BUILDING CODE (2018 EDITION), & BUILDING DEPARTMENT MODIFICATIONS TO THE INTERNATIONAL BUILDING CODE.
2. STRUCTURAL DRAWINGS SHALL BE USED IN CONJUNCTION WITH ARCHITECTURAL DRAWINGS FOR BIDDING AND CONSTRUCTION. CONTRACTOR SHALL VERIFY DIMENSIONS AND CONDITIONS FOR COMPATIBILITY AND SHALL NOTIFY ARCHITECT OF ANY DISCREPANCIES PRIOR TO CONSTRUCTION.
3. CONTRACTOR SHALL BE RESPONSIBLE FOR ALL SAFETY PRECAUTIONS AND THE METHODS, TECHNIQUES, SEQUENCES OR PROCEDURES REQUIRED TO PERFORM THE WORK. THE STRUCTURAL ENGINEER HAS NO OVERALL SUPERVISORY AUTHORITY OR ACTUAL AND/OR DIRECT RESPONSIBILITY FOR THE SPECIFIC WORKING CONDITIONS AT THE SITE AND/OR FOR ANY HAZARDS RESULTING FROM THE ACTIONS OF ANY TRADE CONTRACTOR. THE STRUCTURAL ENGINEER HAS NO DUTY TO INSPECT, SUPERVISE, NOTE, CORRECT, OR REPORT ANY HEALTH OR SAFETY DEFICIENCIES OF THE OWNER, CONTRACTORS, OR OTHER ENTITIES OR PERSONS AT THE PROJECT SITE.
4. SHOP DRAWINGS AND PRODUCT DATA SHALL BE SUBMITTED TO THE ENGINEER PRIOR ANY FABRICATION OR CONSTRUCTION FOR ALL STRUCTURAL ITEMS INCLUDING THE FOLLOWING: STRUCTURAL STEEL, MISCELLANEOUS METAL, TENDONS, ANCHORS, REINFORCING STEEL, GROUTS, AND CONCRETES. THE PROPOSED DEMOLITION AND SHORING SEQUENCE SHALL ALSO BE SUBMITTED TO THE ENGINEER FOR APPROVAL.
5. REFER TO THE FOLLOWING DOCUMENTS FOR ADDITIONAL INFORMATION:
 - A. TOPOGRAPHIC AND BOUNDARY SURVEY: D.R. STRONG CONSULTING ENGINEERS, DATED 5/21/21.
 - B. SOILS REPORT REFERENCE: COBALT GEOSCIENCES, ORIGINAL DATE 4/7/22, UPDATED APRIL 8, 2023.
6. DESIGN LOADS: THE SOIL PRESSURE INDICATED ON THE SOIL PRESSURE DIAGRAM WAS USED FOR DESIGN, IN ADDITION TO THE DEAD AND LIVE LOADS.
7. SPECIAL INSPECTION BY THE SOILS ENGINEER SHALL BE PERFORMED FOR PILE PLACEMENT (AND TIEBACK PLACING AND STRESSING, WHERE APPLICABLE). ALL PREPARED SOIL BEARING SURFACES SHALL BE INSPECTED BY THE SOILS ENGINEER PRIOR TO PLACEMENT OF PILE. SOIL COMPACTION SHALL BE SUPERVISED BY AN APPROVED TESTING LAB.
8. THE SHORING CONTRACTOR SHALL DETERMINE THE LOCATION OF ALL ADJACENT UNDERGROUND UTILITIES PRIOR TO DRILLING PILE HOLES, TIEBACK ANCHORS, OR CUTTING OR DIGGING IN STREETS OR ALLEYS. THE UTILITIES INFORMATION SHOWN ON THE PLANS MAY BE NOT COMPLETE.
9. REFER TO THE SOILS REPORT FOR ADDITIONAL REQUIREMENTS, INCLUDING RECOMMENDATIONS FOR SHORING IN GENERAL, SHORING MONITORING, EXCAVATION, LAGGING, AND DRAINAGE.

SOLDIER PILE AND LAGGING CONSTRUCTION

10. PILE LEAN MIX SHALL CONTAIN 1-1/2 SACKS OF CEMENT PER CUBIC YARD. THERE IS NO STRENGTH REQUIREMENT FOR THIS MIX.
11. LAGGING SHALL CONSIST OF SAWN LUMBER AND SHALL CONFORM TO "GRADING AND DRESSING RULES," WEST COAST LUMBER INSPECTION BUREAU (WCLIB), LATEST EDITION. LAGGING SHALL BE 4X12 DOUGLAS FIR-LARCH NO. 2 OR HEM-FIR NO. 1. TIMBER LAGGING SHALL BE PRESSURE TREATED WITH WATERBORNE PRESERVATIVES IN ACCORDANCE WITH AWPB LP-22 TO A MINIMUM RETENTION OF 0.4 LBS/CU. FT. LAGGING SHALL BE 4X12 UNLESS OTHERWISE NOTED ON DRAWINGS.
12. DEMOLITION: SHORING AND SOIL EXCAVATION SHALL BE DONE SIMULTANEOUSLY.
13. VERIFICATION: DIMENSIONS AND LOCATION OF EXISTING STRUCTURES SHALL BE VERIFIED PRIOR TO FABRICATION AND INSTALLATION OF ANY STRUCTURAL MEMBER. NOTIFY ENGINEER ABOUT ANY DISCREPANCIES PRIOR TO FABRICATION.
14. HOLE DIGGING: PILE AND ANCHOR HOLES SHALL BE DRILLED WITHOUT LOSS OF GROUND AND WITHOUT ENDANGERING PREVIOUSLY INSTALLED PILES AND ANCHORS. THIS MAY INVOLVE CASING THE HOLES OR OTHER METHODS OF PROTECTION FROM CAVING. REFER TO REPORT OF GEOTECHNICAL INVESTIGATION FOR RECOMMENDED HOLE DIGGING PROCEDURE.
15. PILE PLACEMENT: ALTERNATE PILES SHALL BE PLACED AND COMPLETED SO THAT AT LEAST 24 HOURS IS ALLOWED FOR THE CONCRETE TO SET PRIOR TO DRILLING ADJACENT PILES.
16. STEEL PILE PLACEMENT TOLERANCES:
 - 1" INSIDE PERPENDICULAR TO SHORING WALL.
 - 1" OUTSIDE PERPENDICULAR TO SHORING WALL.
 - 3" LATERALLY.

THE CITY OF MERCER ISLAND SHALL BE A RECIPIENT OF THE REPORTS AND REVIEWED SURVEY DATA BY THE GEOTECHNICAL ENGINEER.

17. LAGGING: TIMBER LAGGING SHALL BE INSTALLED IN ALL AREAS. VOIDS BETWEEN LAGGING AND SOIL SHALL BE BACKFILLED. DRAINAGE BEHIND THE WALL MUST BE MAINTAINED. IT IS CONTRACTOR'S RESPONSIBILITY TO LIMIT THE AMOUNT OF EXPOSED SOIL WITHOUT LAGGING TO AVOID LOSS OF SOIL. MAXIMUM HEIGHT OF 4 FEET IS RECOMMENDED. SPECIAL CARE SHOULD BE TAKEN TO AVOID GROUND LOSS DURING EXCAVATION.

SHORING MOVEMENT MONITORING

18. SHORING MONITORING: A SYSTEMATIC PROGRAM OF OBSERVATION SHALL BE CONDUCTED DURING THE PROJECT EXECUTION TO DETERMINE THE EFFECT OF CONSTRUCTION ON ADJACENT FACILITIES AND STRUCTURES IN ORDER TO PROTECT THEM FROM DAMAGE. REFER TO REPORT OF GEOTECHNICAL INVESTIGATION FOR RECOMMENDATIONS.

GROUND SURFACE ELEVATIONS OF THE ADJACENT PROPERTIES AND CITY STREETS SHALL BE DOCUMENTED PRIOR TO DE-WATERING, EXCAVATION, AND INSTALLATION OF THE SHORING SYSTEMS, TO PROVIDE BASELINE DATA.

LOCATIONS: AS A MINIMUM, OPTICAL SURVEY POINTS SHALL BE ESTABLISHED AT THE FOLLOWING LOCATIONS.

- A. THE TOP OF EVERY OTHER SOLDIER PILE.
- B. THE ADJACENT BUILDINGS ALONG THE PROPERTY BOUNDARIES. THERE SHALL BE AT LEAST 2 MONITORING POINTS PER STRUCTURE.
- C. THE CURBS AND THE CENTERLINES OF ADJACENT STREETS. THESE MONITORING POINTS SHALL BE SPACED NO MORE THAN 20 FEET APART.

FREQUENCY: THE MONITORING POINTS AT THE TOP OF EVERY OTHER PILE SHALL BE SURVEYED A MINIMUM OF TWICE A WEEK DURING SHORING INSTALLATION AND EXCAVATION, WITH ONCE A WEEK BEING DONE BY A LICENSED LAND SURVEYOR. THE MONITORING POINTS AT THE ADJACENT BUILDINGS, CURBS, AND STREETS SHALL BE REGULARLY SURVEYED WITH THE SOLDIER PILES.

SURVEY FREQUENCY MAY BE DECREASED AFTER THE SHORING SYSTEM HAS BEEN INSTALLED AND EXCAVATION IS COMPLETE IF THE DATA INDICATES LITTLE OR NO ADDITIONAL MOVEMENT. SURVEYING MUST CONTINUE UNTIL THE PERMANENT STRUCTURE (INCLUDING FLOOR SLABS AS BRACES) IS COMPLETE UP TO FINAL AND STREET GRADES. ANY SURVEY FREQUENCY CHANGES WILL BE DETERMINED BY THE GEOTECHNICAL ENGINEER AFTER REVIEW AND APPROVAL BY SDCI (AND SDOT, IF APPLICABLE).

THE MONITORING PROGRAM SHALL INCLUDE CHANGES IN BOTH THE HORIZONTAL (NORTH-SOUTH AND EAST-WEST) DIRECTIONS AND VERTICAL DIRECTIONS. THE MONITORING SHALL BE PERFORMED BY THE CONTRACTOR OR THE PROJECT SURVEYOR, AND THE RESULTS SHALL BE PROMPTLY SUBMITTED TO THE STRUCTURAL AND GEOTECHNICAL ENGINEERS FOR REVIEW.

THE GEOTECHNICAL ENGINEER SHALL REVIEW SURVEY DATA AND PROVIDE AN EVALUATION OF WALL PERFORMANCE ALONG WITH SURVEY DATA TO SDCI (AND SDOT, IF APPLICABLE) ON AT LEAST A WEEKLY BASIS. IMMEDIATELY AND DIRECTLY, NOTIFY SDCI (AND SDOT, IF APPLICABLE) IF ANY UNUSAL OR SIGNIFICANTLY INCREASED MOVEMENT OCCURS.

IMMEDIATELY AND DIRECTLY NOTIFY THE GEOTECHNICAL AND STRUCTURAL ENGINEERS, WALL DESIGNER, SDCI, (AND SDOT, IF APPLICABLE) IF 0.5 INCHES OF MOVEMENT OCCURS BETWEEN TWO CONSECUTIVE READINGS AND WHEN TOTAL MOVEMENTS REACH 0.5 INCH. AT THAT AMOUNT OF MOVEMENT, THE ENGINEERS AND DESIGNERS SHALL DETERMINE THE CAUSE OF DISPLACEMENT AND DEVELOP REMEDIAL MEASURES SUFFICIENT TO LIMIT TOTAL WALL MOVEMENTS TO 1 INCH. ALL EARTHWORK AND CONSTRUCTION ACTIVITIES MUST BE DIRECTED TOWARDS IMMEDIATE IMPLEMENTATION OF REMEDIAL MEASURES NECESSARY TO LIMIT TOTAL WALL MOVEMENTS TO WHAT HAS BEEN DEFINED AS ACCEPTABLE BY THE DESIGN TEAM AND SDOT (IF APPLICABLE).

SDOT ALLOWS AS A MAXIMUM ONE INCH HORIZONTAL DISPLACEMENT ANYWHERE ON SHORING WALL SURFACES THROUGHOUT THE SHORING WALL SERVICE LIFE TIME. CONSTRUCTION SHALL BE SUSPENDED IMMEDIATELY AND REMEDIAL PROCEDURES APPLIED AS LONG AS A DISPLACEMENT READING EXCEEDS ONE INCH.

TIEBACK CONSTRUCTION

19. TIEBACK LEAN MIX SHALL CONTAIN 1-1/2 SACKS OF CEMENT PER CUBIC YARD. THERE IS NO STRENGTH REQUIREMENT FOR THIS MIX.
20. PRESTRESSING STEEL SHALL CONFORM TO THE FOLLOWING REQUIREMENTS:
 - A. DYWIDAG THREAD BAR SHALL CONFORM TO ASTM SPECIFICATION A-722 FOR HOT ROLLED, PROOF STRESSED ALLOY STEEL, $p_{fu} = 150$ KSI.
 - B. UNCOATED SEVEN WIRE STRESS RELIEVED STRAND SHALL CONFORM TO ASTM A416, GRADE 270.

21. TIEBACK INSTALLATION AND PRESTRESSING SHALL BE COMPLETED PRIOR TO EXCAVATING MORE THAN TWO FEET BELOW TIEBACK LEVEL.
22. TIEBACKS SHALL REMAIN STRESSED UNTIL ALL PERMANENT STRUCTURE IS IN PLACE.
23. ALL TIEBACKS SHALL BE DESTRESSED UPON THE COMPLETION OF THE PROJECT.
24. VERIFICATION TESTS SHALL BE PROVIDED AS FOLLOWS:

- A. TWO HUNDRED PERCENT VERIFICATION TESTS SHALL BE CONDUCTED ON AT LEAST TWO ANCHORS IN EACH PARTICULAR SOIL TYPE. A MINIMUM OF FOUR ANCHORS SHALL BE SELECTED BY THE GEOTECHNICAL ENGINEER FOR TESTING DURING THE COURSE OF CONSTRUCTION.
- B. THE MAXIMUM STRESS IN PRESTRESSING STEEL SHALL NOT EXCEED 80% OF THE ULTIMATE TENSILE STRENGTH DURING PERFORMANCE TESTING. PILES AND TIEBACKS MAY REQUIRE EXTRA REINFORCEMENT TO PERMIT STRESSING TO 200% OF DESIGN LOAD AS REQUIRED BY THE VERIFICATION TEST.
- C. THE VERIFICATION TESTS SHALL MEASURE ANCHOR STRESS AND DISPLACEMENT INCREMENTALLY TO VALUES OF UNIT SKIN FRICTION EQUAL TO 200% OF THE DESIGN STRESS. THE ANCHOR SHALL BE LOADED IN 10% INCREMENTS WITH EACH INCREMENT HELD FOR AT LEAST FIVE MINUTES. THE FINAL MAXIMUM TEST LOAD SHALL BE MAINTAINED FOR A PERIOD OF AT LEAST THIRTY MINUTES. MEASUREMENTS OF MOVEMENT SHALL BE OBTAINED WITH A TRANSIT AND A SCALE ACCURATE TO 0.01 INCH ATTACHED TO THE ROD. TEST ANCHORS SHALL HOLD THE MAXIMUM TEST UNIT STRESS WITHOUT NOTICEABLE CREEP AND EXHIBIT A LINEAR OR NEAR-LINEAR RELATIONSHIP BETWEEN UNIT ANCHOR STRESS AND MOVEMENT OVER THE ENTIRE 200% STRESS RANGE. NOTICEABLE CREEP SHALL BE DEFINED AS A RATE OF MOVEMENT OF APPROXIMATELY 0.08 INCHES/LOG CYCLE OF TIME. TESTS SHALL BE PERFORMED WITHOUT THE BACKFILL AHEAD OF THE ANCHOR TO AVOID ANY CONTRIBUTORY RESISTANCE BY THE BACKFILL, UNLESS APPROVAL TO THE CONTRARY IS GRANTED BY THE GEOTECHNICAL ENGINEER.

25. PRODUCTION ANCHORS:

- A. EACH PRODUCTION ANCHOR SHALL BE PROOF-LOADED TO 130% OF THE DESIGN LOAD AND SHALL SUSTAIN THE PROOF LOAD WITHOUT NOTICEABLE CREEP OR EXCESSIVE ANCHOR MOVEMENT FOR FIVE MINUTES. THE ANCHOR SHALL BE LOADED IN INCREMENTS OF 25% OF THE DESIGN LOAD, WITH EACH LOAD HELD FOR AT LEAST FIVE MINUTES, IN ORDER TO OBTAIN A STABLE DISPLACEMENT MEASUREMENT.
- B. MOVEMENT OF THE ANCHOR IN EXCESS OF 3 INCHES SHALL BE CONSIDERED INDICATIVE OF DEFICIENCIES IN THE INSTALLATION. TOTAL MOVEMENT OF AN ANCHOR IN EXCESS OF 6 INCHES SHALL BE CONSIDERED A FAILURE REQUIRING A REPLACEMENT ANCHOR. TOTAL MOVEMENT OF AN ANCHOR BETWEEN 3 INCHES AND 6 INCHES SHALL BE REVIEWED BY THE GEOTECHNICAL AND STRUCTURAL ENGINEER TO DETERMINE IF A REPLACEMENT ANCHOR IS REQUIRED.
- C. FOLLOWING PROOF LOADING, EACH ANCHOR SHALL BE LOCKED OFF AT 100% OF DESIGN LOADING.

26. THE GEOTECHNICAL ENGINEER SHALL PROVIDE THE RESULTS OF THE VERIFICATION AND PROOF LOAD TESTS TO THE CITY OF MERCER ISLAND IN THEIR FIELD REPORTS, WHICH SHALL ALSO BE FILED WITH THE CITY. RESULTS OF THE VERIFICATION TESTING OBSERVED AND ANALYZED BY THE GEOTECHNICAL ENGINEER OF RECORD SHALL BE SUBMITTED TO THE CITY OF MERCER ISLAND [GEOTECHNICAL PEER REVIEWER] PRIOR TO APPLYING DESIGN LOADING TO THE REMAINDER OF THE ANCHORS.

ANY FAILED TESTS SHALL BE REPORTED TO THE BUILDING OFFICIAL ALONG WITH THE PROPOSED DESIGN REVISIONS FOR APPROVAL.

27. THE ABILITY TO ACHIEVE THE REQUIRED TIEBACK STRENGTH (4.71 KIP/FT) WILL LIKELY REQUIRE POST OR SECONDARY GROUTING.

28. THE CONTRACTOR SHALL DETERMINE THE ANCHOR DIAMETER, INSTALLATION METHOD, AND GROUTING PROCEDURES NECESSARY TO OBTAIN THE REQUIRED ANCHOR LOADS WITHOUT ENCRUCHING ON THE ADJACENT PROPERTY TO THE EAST. ANY STRUCTURAL MODIFICATIONS SHALL BE APPROVED BY THE STRUCTURAL ENGINEER OF RECORD.

HV

Harriott Valentine Engineers Inc.
1932 First Avenue, Suite 720
Seattle, Washington 98101-2447
tel 206 624 4760 fax 206 447 6971
www.harriottvalentine.com



Project Contact
Conrad Beymer
tel 206 756 0391
fax 206 447 6971
cbeymer@harriottvalentine.com

Project Architect
SHED Architecture & Design
1404 S Jackson Street
Seattle, WA 98144

Project
Sullivan Residence
3024 69th Ave SE
Mercer Island, WA 98040

Issue Date	Issue Description
1/20/2023	Permit
5/5/2023	Corrections 1
6/29/2023	Corrections 2

Building Department Approval

Drawing Title
TEMPORARY SHORING GENERAL NOTES

Drawing Number

T1.0

SULLIVAN RESIDENCE

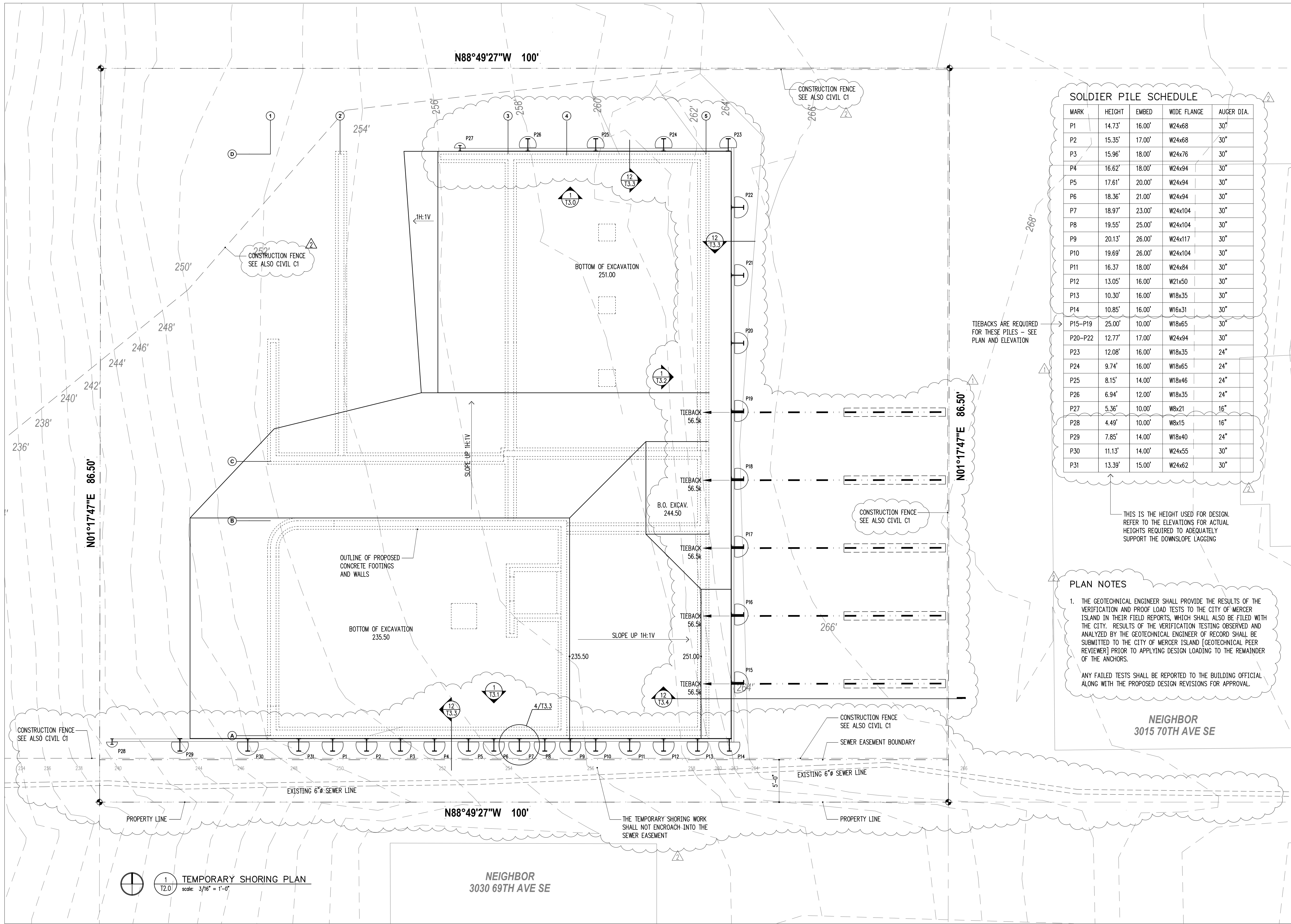

SOLDIER PILE SCHEDULE

MARK	HEIGHT	EMBED	WIDE FLANGE	AUGER DIA.
P1	14.73'	16.00'	W24x68	30"
P2	15.35'	17.00'	W24x68	30"
P3	15.96'	18.00'	W24x76	30"
P4	16.62'	18.00'	W24x94	30"
P5	17.61'	20.00'	W24x94	30"
P6	18.36'	21.00'	W24x94	30"
P7	18.97'	23.00'	W24x104	30"
P8	19.55'	25.00'	W24x104	30"
P9	20.13'	26.00'	W24x117	30"
P10	19.69'	26.00'	W24x104	30"
P11	16.37'	18.00'	W24x84	30"
P12	13.05'	16.00'	W21x50	30"
P13	10.30'	16.00'	W18x35	30"
P14	10.85'	16.00'	W16x31	30"
P15-P19	25.00'	10.00'	W18x65	30"
P20-P22	12.77'	17.00'	W24x94	30"
P23	12.08'	16.00'	W18x35	24"
P24	9.74'	16.00'	W18x65	24"
P25	8.15'	14.00'	W18x46	24"
P26	6.94'	12.00'	W18x35	24"
P27	5.36'	10.00'	W8x21	16"
P28	4.49'	10.00'	W8x15	16"
P29	7.85'	14.00'	W18x40	24"
P30	11.13'	14.00'	W24x55	30"
P31	13.39'	15.00'	W24x62	30"

TIEBACKS ARE REQUIRED FOR THESE PILES - SEE PLAN AND ELEVATION

THIS IS THE HEIGHT USED FOR DESIGN. REFER TO THE ELEVATIONS FOR ACTUAL HEIGHTS REQUIRED TO ADEQUATELY SUPPORT THE DOWNSLOPE LAGGING

PLAN NOTES

1. THE GEOTECHNICAL ENGINEER SHALL PROVIDE THE RESULTS OF THE VERIFICATION AND PROOF LOAD TESTS TO THE CITY OF MERCER ISLAND IN THEIR FIELD REPORTS, WHICH SHALL ALSO BE FILED WITH THE CITY. RESULTS OF THE VERIFICATION TESTING OBSERVED AND ANALYZED BY THE GEOTECHNICAL ENGINEER OF RECORD SHALL BE SUBMITTED TO THE CITY OF MERCER ISLAND [GEOTECHNICAL PEER REVIEWER] PRIOR TO APPLYING DESIGN LOADING TO THE REMAINDER OF THE ANCHORS.

ANY FAILED TESTS SHALL BE REPORTED TO THE BUILDING OFFICIAL ALONG WITH THE PROPOSED DESIGN REVISIONS FOR APPROVAL.

**NEIGHBOR
3015 70TH AVE SE**

1/22.0 TEMPORARY SHORING PLAN
scale: 3/16" = 1'-0"

**NEIGHBOR
3030 69TH AVE SE**

HV
Harriott Valentine Engineers Inc.
1932 First Avenue, Suite 720
Seattle, Washington 98101-2447
tel 206 624 4760 fax 206 447 6971
www.harriottvalentine.com



Project Contact
Conrad Beymer
tel 206 756 0391
fax 206 447 6971
cbeymer@harriottvalentine.com

Project Architect
SHED Architecture & Design
1404 S Jackson Street
Seattle, WA 98144

Project
Sullivan Residence
3024 69th Ave SE
Mercer Island, WA 98040

Issue Date	Issue Description
1/20/2023	Permit
5/5/2023	Corrections 1
6/29/2023	Corrections 2

Building Department Approval

Drawing Title
TEMPORARY SHORING PLAN

Drawing Number
T2.0

SULLIVAN RESIDENCE

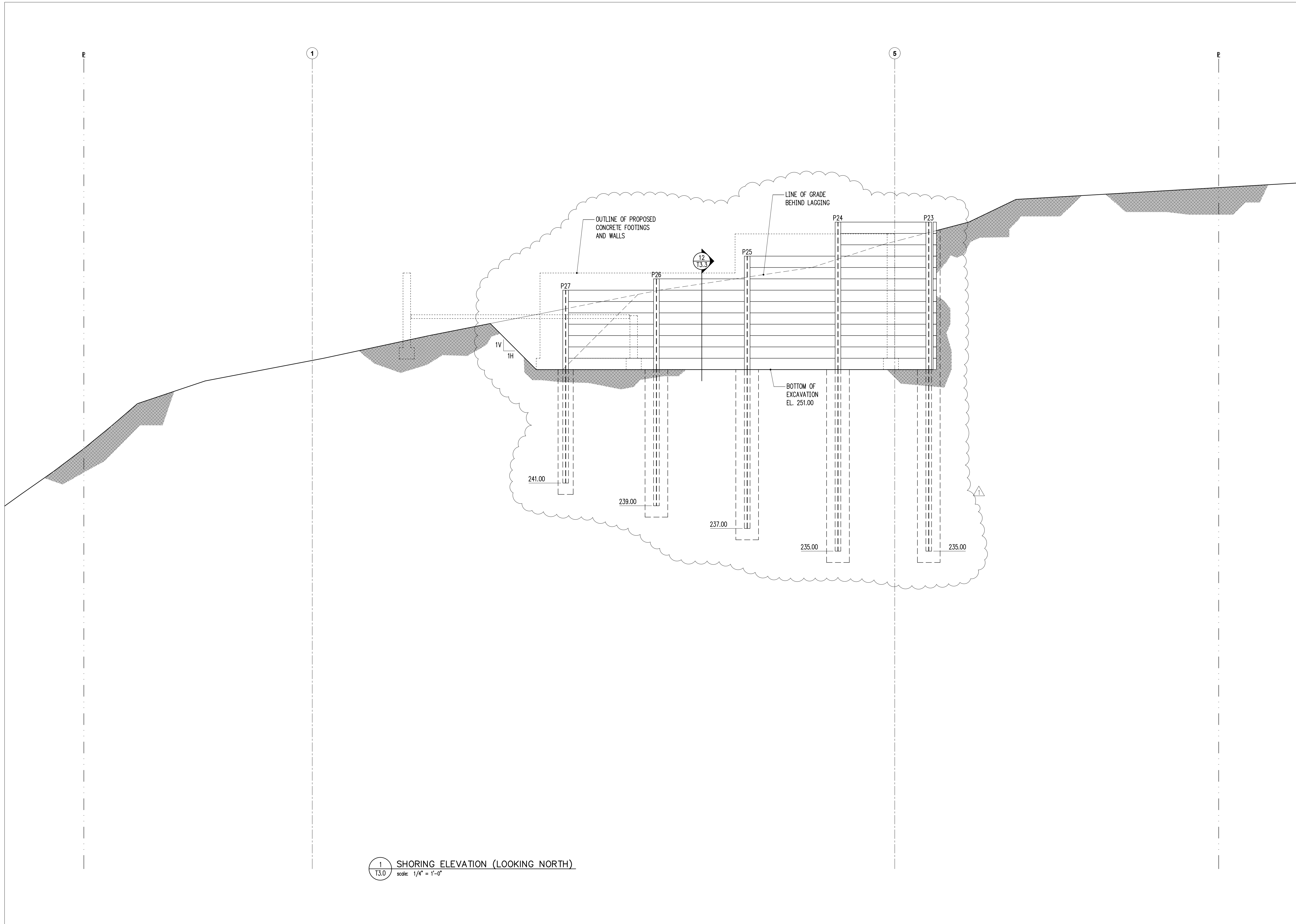

1 SHORING ELEVATION (LOOKING NORTH)
 T3.0 scale: 1/4" = 1'-0"

HV

Harriott Valentine Engineers Inc.
 1932 First Avenue, Suite 720
 Seattle, Washington 98101-2447
 tel 206 624 4760 fax 206 447 6971
 www.harriottvalentine.com



Project Contact
 Conrad Beymer
 tel 206 756 0391
 fax 206 447 6971
 cbeymer@harriottvalentine.com

Project Architect
 SHED Architecture & Design
 1404 S Jackson Street
 Seattle, WA 98144

Project
Sullivan Residence
 3024 69th Ave SE
 Mercer Island, WA 98040

Issue Date	Issue Description
1/20/2023	Permit
5/5/2023	Corrections 1
6/29/2023	Corrections 2

Building Department Approval

Drawing Title
TEMPORARY SHORING ELEVATIONS

Drawing Number
T3.0

SULLIVAN RESIDENCE



1 SHORING ELEVATION (LOOKING SOUTH)
 T3.2 scale: 1/4" = 1'-0"

HV
 Harriott Valentine Engineers Inc.
 1932 First Avenue, Suite 720
 Seattle, Washington 98101-2447
 tel 206 624 4760 fax 206 447 6971
 www.harriottvalentine.com



Project Contact
 Conrad Beymer
 tel 206 756 0391
 fax 206 447 6971
 cbeymer@harriottvalentine.com

Project Architect
 SHED Architecture & Design
 1404 S Jackson Street
 Seattle, WA 98144

Project
Sullivan Residence
 3024 69th Ave SE
 Mercer Island, WA 98040

Issue Date	Issue Description
1/20/2023	Permit
5/5/2023	Corrections 1
6/29/2023	Corrections 2

Building Department Approval

Drawing Title
TEMPORARY SHORING ELEVATIONS

Drawing Number
T3.1

SULLIVAN RESIDENCE

3/4" = 1'-0" 1

3/4" = 1'-0" 2

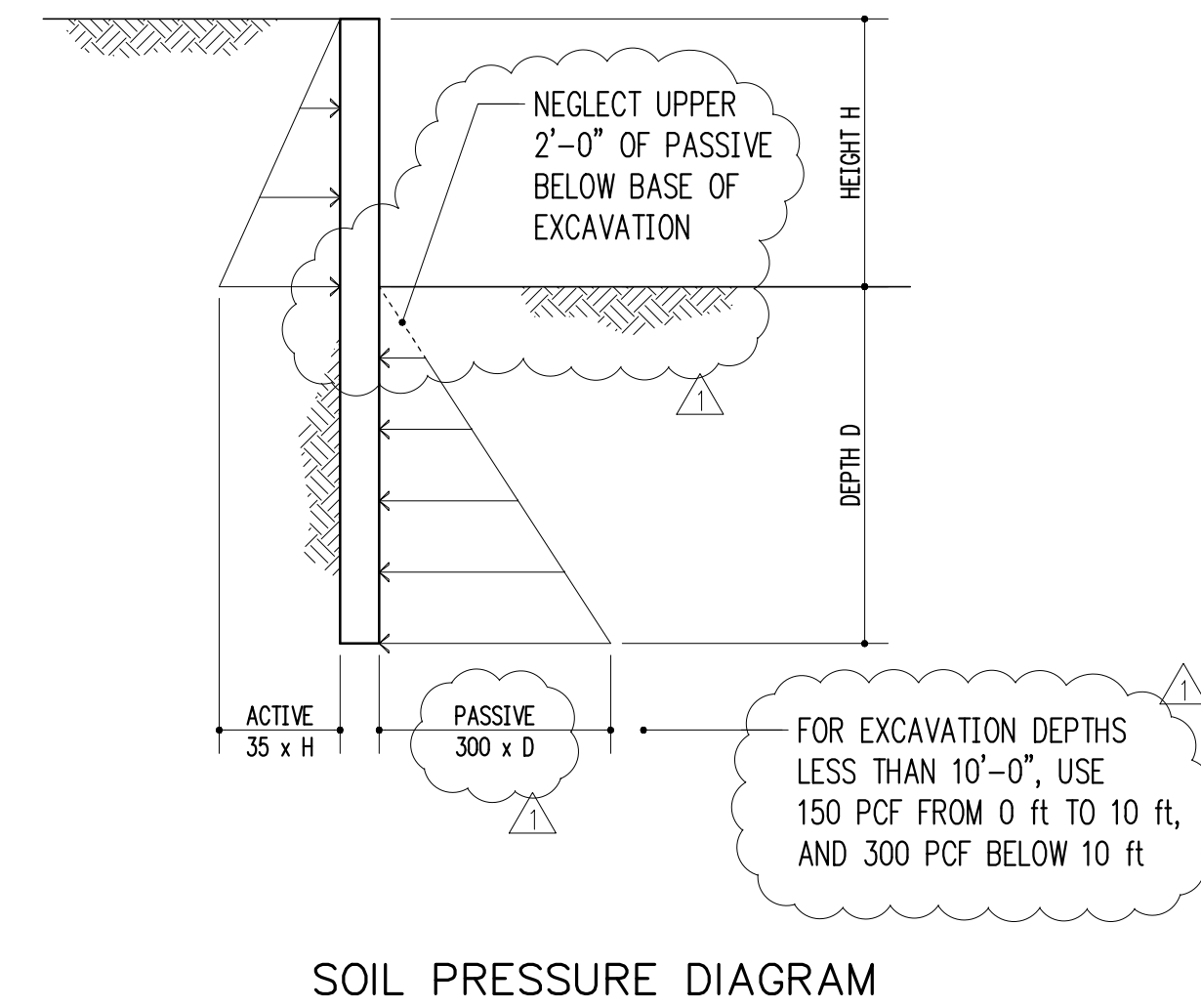

SOIL PRESSURE DIAGRAM

3/4" NO SCALE 3

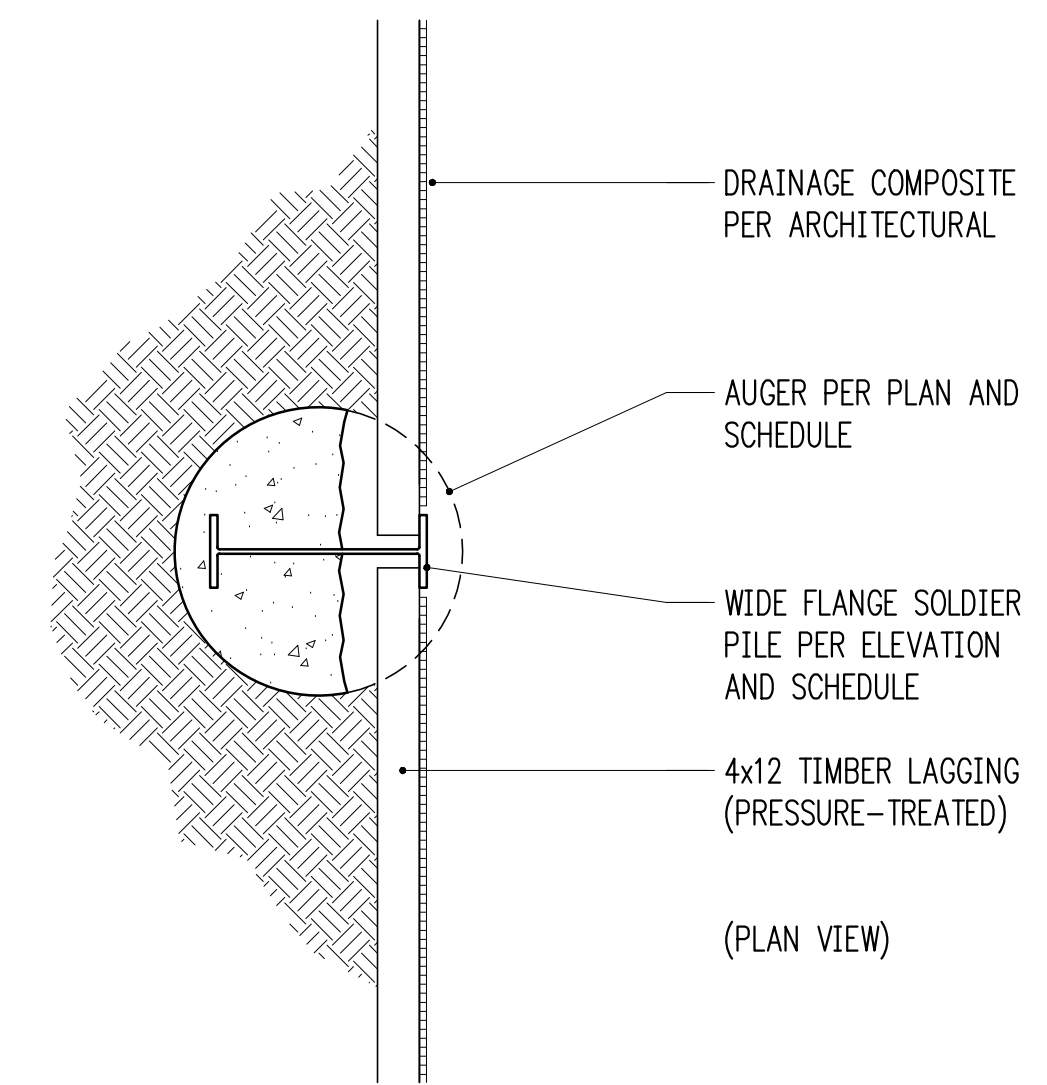

(PLAN VIEW)

3/4" = 1'-0" 4

3/4" = 1'-0" 5

3/4" = 1'-0" 6

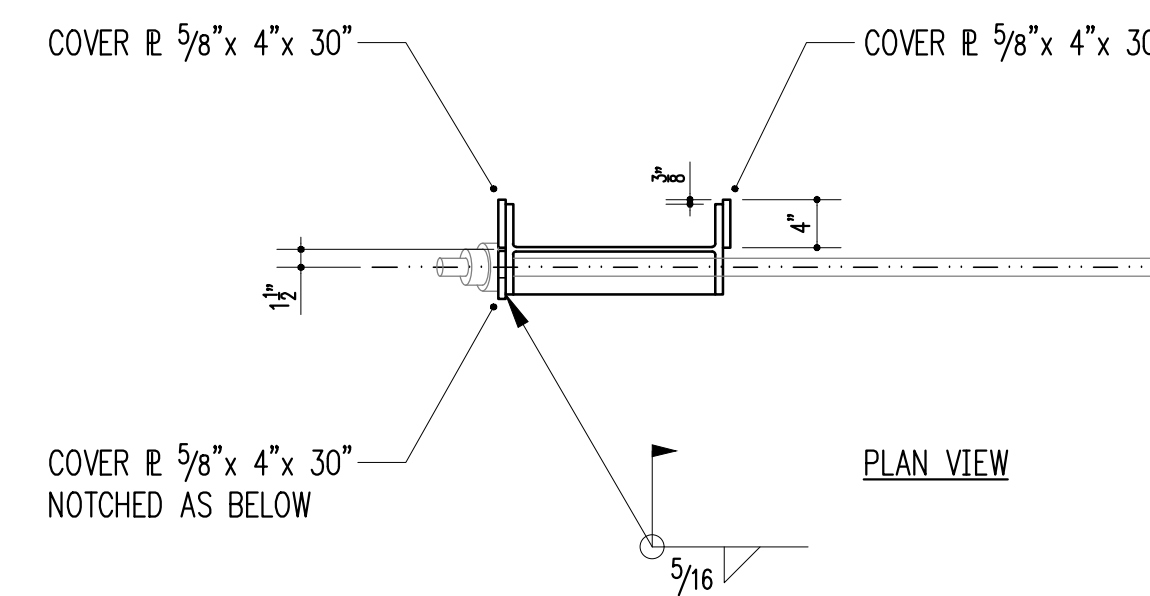

PLAN VIEW

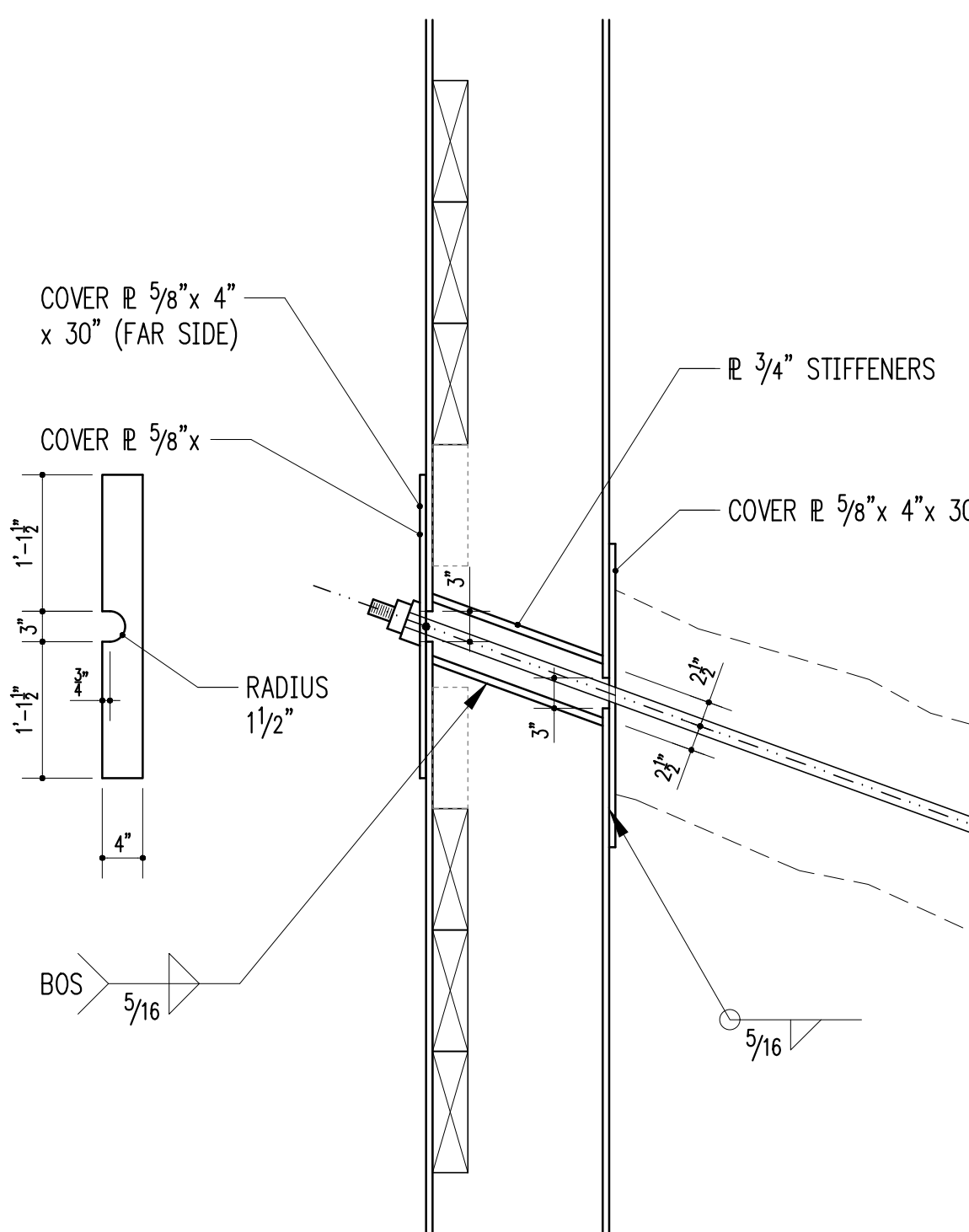

3/4" = 1'-0" 11

3/4" = 1'-0" 9

3/4" = 1'-0" 10

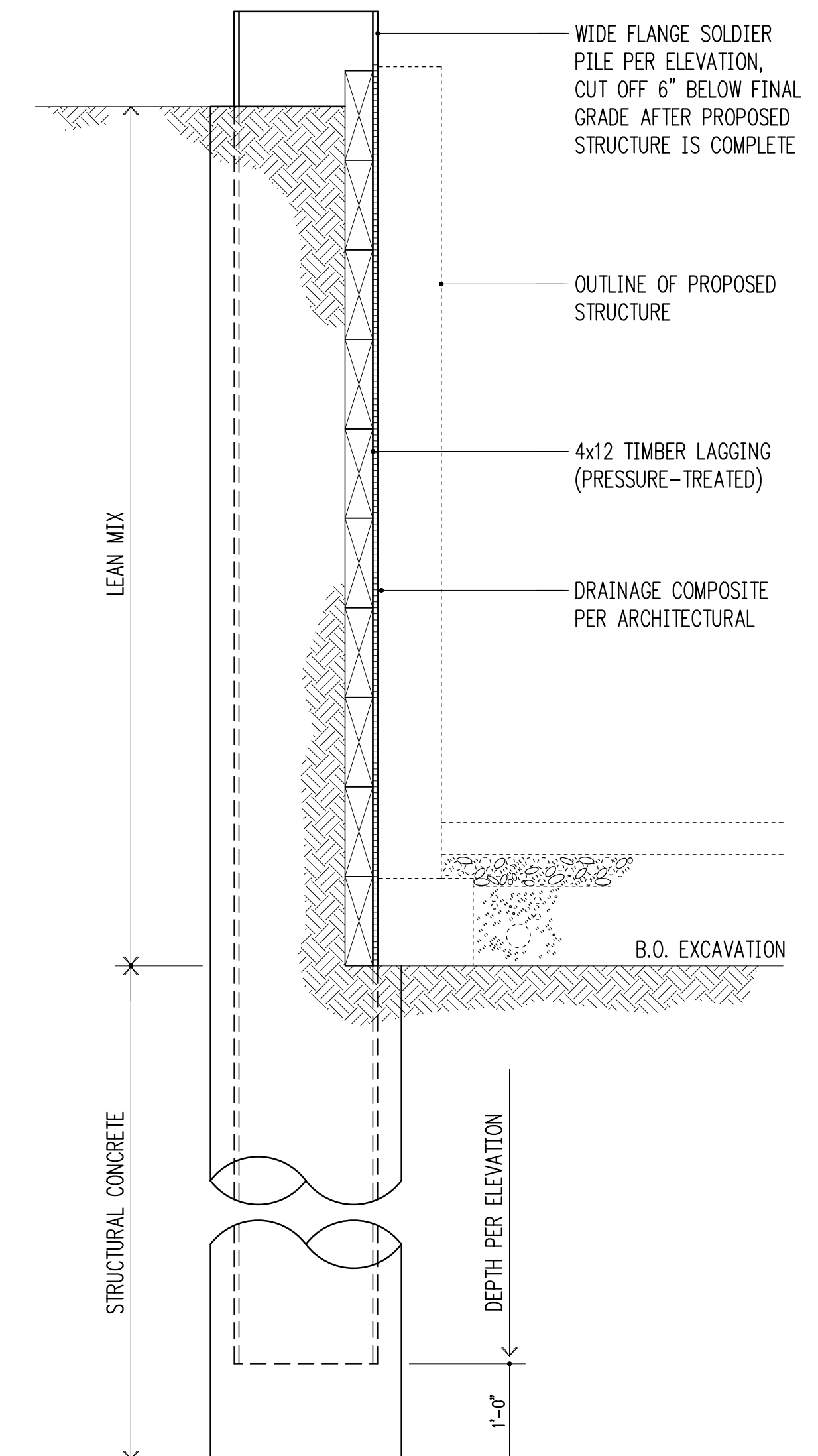

3/4" = 1'-0" 12

HV

Harriott Valentine Engineers Inc.
1932 First Avenue, Suite 720
Seattle, Washington 98101-2447
tel 206 624 4760 fax 206 447 6971
www.harriottvalentine.com



Project Contact
Conrad Beymer
tel 206 756 0391
fax 206 447 6971
cbeymer@harriottvalentine.com

Project Architect
SHED Architecture & Design
1404 S Jackson Street
Seattle, WA 98144

Project
Sullivan Residence
3024 69th Ave SE
Mercer Island, WA 98040

Issue Date	Issue Description
1/20/2023	Permit
5/5/2023	Corrections 1
6/29/2023	Corrections 2

Building Department Approval

Drawing Title
**TEMPORARY SHORING
DETAILS**

Drawing Number

T3.3

SULLIVAN RESIDENCE

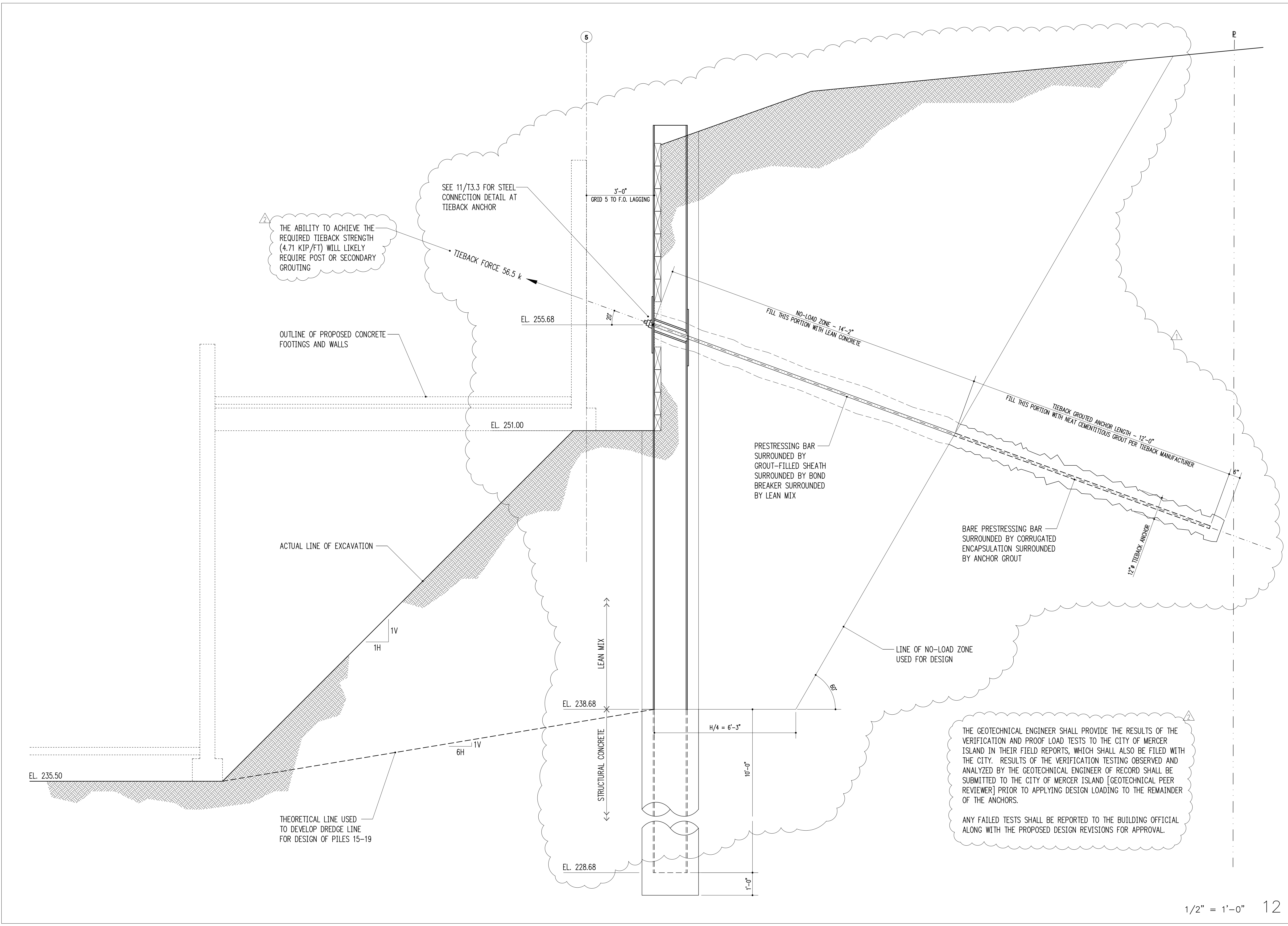

HV
 Harriott Valentine Engineers Inc.
 1932 First Avenue, Suite 720
 Seattle, Washington 98101-2447
 tel 206 624 4760 fax 206 447 6971
 www.harriottvalentine.com



Project Contact
 Conrad Beymer
 tel 206 756 0391
 fax 206 447 6971
 cbeymer@harriottvalentine.com

Project Architect
 SHED Architecture & Design
 1404 S Jackson Street
 Seattle, WA 98144

Project
Sullivan Residence
 3024 69th Ave SE
 Mercer Island, WA 98040

Issue Date	Issue Description
1/20/2023	Permit
5/5/2023	Corrections 1
6/29/2023	Corrections 2

Building Department Approval

Drawing Title
**TEMPORARY SHORING
 DETAILS**

Drawing Number

T3.4